

STUDY MATERIAL

SUBJECT : MATHEMATICS

CLASS X

KENDRIYA VIDYALAYA SANGATHAN

REGIONAL OFFICE PATNA

YEAR 2012-13

PREFACE

In compliance to kVS(HQ), New Delhi letter no.28350(SM)/2012-13KVSPR/ dated 01.08.2012 the responsibility of preparation of Study/ Support Material class X mathematics has been entrusted to this Region

KVS Patna Region acknowledges the sincere efforts of Sh. Sudhakar Singh, Principal, KV No.2 Gaya, Ms.Archita Gupta, PGT(Maths), Dr. A.K.Tiwari, TGT(Maths), Sh. S.Ram, TGT(Maths) and Sh. P.N.Chaki, PGT(Comp.Sc).

I am confident that the study/support material class x mathematics will directly help the students to understand the concept well and meet quality expectation.

Wish you all the best.

(.....)

Dy. Commissioner

STUDY MATERIAL – MATHEMATICS

FOR

CLASS – X

(2012-2013)

PATRON

DY. COMMISSIONER

COORDINATOR

SH. SUDHAKAR SINGH

PRINCIPAL, KV NO.2 GAYA

RESOURCE PERSONS

MS. ARCHITA GUPTA, PGT(MATHS), KV NO.2 GAYA

DR. A.K.TIWARI, TGT(MATHS), KV NO.2 GAYA

SH. S.RAM, TGT(MATHS), KV NO.2 GAYA

SH. P.N.CHAKI, PGT(COMP.SC), KV NO.2 GAYA

SH. SUDHAKAR SINGH, PRINCIPAL, KV NO.2 GAYA

How to use this study material?

Dear Children,

This study material contains gist of the topics/units along with the assignments for self assessment. Here are some tips to use this study material while revision during pre-boards and finally in board examination.

- Go through the syllabus given in the beginning. Identify the units carrying more weightage.
- Suggestive blue print and design of question paper is a guideline for you to have clear picture about the form of the question paper.
- Revise each of the topics/ units and attempt the questions given for self assessment.
- After attempting the self assessment part, consult the question bank where questions carrying one, two , three, four marks are given. Revise them.
- After revision of all the units, solve the sample paper, and do self assessment with the value points.
- Must study the marking scheme/solution for CBSE previous year paper which will enable you to know the coverage of content under different questions.
- Underline or highlight key ideas to have birds eye view of all the units at the time of examination.
- Write down your own notes and make summaries with the help of this study material.
- Turn the theoretical information into outline mind maps.
- Make a separate revision note book for diagrams and numericals as well.
- Discuss your 'DOUBTS' with your teacher/other students.
- Use part2 for FA-2 and FA-4

Important:

- Slow learners may revise the knowledge part first.
- Bright students may emphasize the application part of the question paper.

INDEX

SLNO	TOPIC	PAGE NO.
	PART -1	
	SA-1	
1	Real Numbers	
2	Polynomials	
3	A pair of linear equations in two variables	
4	Triangles	
5	Introduction to Trigonometry	
6	Statistics	
7	Model Question paper SA-1	
	SA- 2	
8	Quadratic Equation	
9	Arithmetic Progression	
10	Coordinate Geometry	
11	Some Applications of Trigonometry	
12	Circle	
13	Construction	
14	Area Related to Circle	
15	Surface Area and Volume	
16	Probability	
17	Model Question paper SA-2	
	PART – 2	
18	Activities (Term I)	
19	Activities (Term II)	
20	Projects	
21	Quiz/oral Test	
22	Puzzles	

**COURSE STRUCTURE
CLASS X**

- As per CCE guidelines, the syllabus of Mathematics for class X has been divided term wise.
- The units specified for each term shall be assessed through both formative and summative assessment.
- In each term, there shall be two formative assessments each carrying 10% weightage.
- The summative assessment in I term will carry 30% weightage and the summative assessment in the II term will carry 30% weightage.
- Listed laboratory activities and projects will necessarily be assessed through formative assessments.

SUMMATIVE ASSESSMENT -1

FIRST TERM (SA I)	MARKS: 90
UNITS	MARKS
I NUMBER SYSTEM Real Numbers	11
II ALGEBRA Polynomials, pair of linear equations in two variables.	23
III GEOMETRY Triangles	17
V TRIGONOMETRY Introduction to trigonometry, trigonometric identity.	22
VII STATISTICS	17
TOTAL	90

SUMMATIVE ASSESSMENT -2

SECOND TERM (SA II)	MARKS: 90
UNITS	MARKS
II ALGEBRA(contd) Quadratic equations, arithmetic progressions	23
III GEOMETRY(contd) Circles, constructions	17
IV MENSURATION Areas related to Circles, Surface Area & Volumes	23
V TRIGONOMETRY(Contd) Heights and Distances.	08
VI COORDINATE GEOMETRY	11
VII PROBABILITY	08
TOTAL	90

**DETAILS OF THE CONCEPTS TO BE MASTERED BY EVERY CHILD OF CLASS X
WITH EXERCISE AND EXAMPLES OF NCERT TEXT BOOK**

SA-I

SYMBOLS USED

*:-Important Questions, **:- Very important Questions, ***:- Very very important Questions

S.No	TOPIC	CONCEPTS	DEGREE OF IMPORTANCE	References(NCERT BOOK)
01	Real Number	Euclid's division Lemma & Algorithm	***	Example -1,2,3,4 Ex:1.1 Q:1,2,4
		Fundamental Theorem of Arithmetic	***	Example -5,7,8 Ex:1.2 Q:4,5
		Revisiting Irrational Numbers	***	Example -9,10,11 Ex: 1.3 Q:1.2 Th:1.4
		Revisiting Rational Number and their decimal Expansion	**	Ex -1.4 Q:1
02	Polynomials	Meaning of the zero of Polynomial	*	Ex -2.1 Q:1
		Relationship between zeroes and coefficients of a polynomial	**	Example -2,3 Ex-2.2 Q:1
		Forming a quadratic polynomial	**	Ex -2.2 Q:2
		Division algorithm for a polynomial	*	Ex -2.3 Q:1,2
		Finding the zeroes of a polynomial	***	Example: 9 Ex -2.3 Q:1,2,3,4,5 Ex-2.4,3,4,5
03	Pair of Linear Equations in two variables	Graphical algebraic representation	*	Example:2,3 Ex -3.4 Q:1,3
		Consistency of pair of liner equations	**	Ex -3.2 Q:2,4
		Graphical method of solution	***	Example: 4,5 Ex -3.2 Q:7
		Algebraic methods of solution a. Substitution method b. Elimination method c. Cross multiplication method d. Equation reducible to pair of liner equation in two variables	**	Ex -3.3 Q:1,3 Example-13 Ex:3.4 Q:1,2 Example-15,16 Ex:3.5 Q:1,2,4 Example-19 Ex-3.6 Q :1(ii),(viii),2 (ii),(iii)
04	TRIANGLES	1) Similarity of Triangles	***	Theo:6.1 Example:1,2,3 Ex:6.2 Q:2,4,6,9,10

		2) Criteria for Similarity of Triangles	**	Example:6,7 Ex:6.3 Q:4,5,6,10,13,16
		3) Area of Similar Triangles	***	Example:9 The:6.6 Ex:6.4 Q:3,5,6,7
		4) Pythagoras Theorem	***	Theo:6.8 & 6.9 Example:10,12,14, Ex:6.5 Q:4,5,6,7,13,14,15,16
05	Introduction to Trigonometry	1) Trigonometric Ratios	*	Ex:8.1 Q:1,2,3,6,8,10
		2) Trigonometric ratios of some specific angles	**	Example:10,11 Ex:8.2 Q:1,3
		3) Trigonometric ratios of complementary angles	**	Example:14,15 Ex:8.3 Q:2,3,4,6
		4) Trigonometric Identities	***	Ex:8.4 Q:5 (iii,v,viii)
06	STATISTICS	CONCEPT 1 Mean of grouped data		
		1. Direct Method	***	Example:2 Ex:14.1 Q:1&3
		2. Assumed Mean Method	*	Ex:14.1 Q:6
		3. Step Deviation Method	*	Ex:14.1 Q:9
		CONCEPT 2 Mode of grouped data	***	Example:5 Ex:14.2 Q:1,5
		CONCEPT 3 Median of grouped data	***	Example:7,8 Ex:14.3 Q1,3,5
		CONCEPT 4 Graphical representation of c.f.(ogive)	**	Example:9 Ex:14.4 Q:1,2,3

1.Real numbers
(Key Points)

1. **Euclid's Division lemma:-** Given Positive integers a and b there exist unique integers q and r satisfying
 $a = bq + r$, where $0 \leq r < b$, where a, b, q and r are respectively called as dividend, divisor, quotient and remainder.
2. **Euclid's division Algorithm:-** To obtain the HCF of two positive integers say c and d, with $c > 0$, follow the steps below:

Step I: Apply Euclid's division lemma, to c and d, so we find whole numbers, q and r such that $c = dq + r$, $0 \leq r < d$.

Step II: If $r = 0$, d is the HCF of c and d. If $r \neq 0$, apply the division lemma to d and r.

Step III: Continue the process till the remainder is zero. The divisor at this stage will be the required HCF

3. The Fundamental theorem of Arithmetic:-

Every composite number can be expressed (factorised) as a product of primes, and this factorization is unique, apart from the order in which the prime factors occur.

Ex.: $24 = 2 \times 2 \times 2 \times 3 = 3 \times 2 \times 2 \times 2$

Theorem: LET x be a rational number whose decimal expansion terminates. Then x can be expressed in the form

Of $\frac{p}{q}$ where p and q are co-prime and the prime factorisation of q is the form of $2^n \cdot 5^m$, where n, m are non negative integers.

Ex. $\frac{7}{10} = \frac{7}{2 \times 5} = 0.7$

Theorem: LET $x = \frac{p}{q}$ be a rational number such that the prime factorisation of q is not of the form of $2^n \cdot 5^m$, where n, m are non negative integers. Then x has a decimal expansion which is non terminating repeating (recurring).

Ex. $\frac{7}{6} = \frac{7}{2 \times 3} = 1.1666 \dots$

Theorem: For any two positive integers a and b,

$HCF(a, b) \times LCM(a, b) = a \times b$

Ex.: 4 & 6; $HCF(4, 6) = 2$, $LCM(4, 6) = 12$; $HCF \times LCM = 2 \times 12 = 24$

Ans. : $a \times b = 24$

(Level- 1)

1. If $\frac{p}{q}$ is a rational number ($q \neq 0$). What is the condition on q so that the decimal representation of $\frac{p}{q}$ is terminating?
Ans. q is form of $2^n \cdot 5^m$ where n, m are non negative integers.
2. Write a rational number between $\sqrt{2}$ and $\sqrt{3}$.
Ans. 1.5
3. The decimal expansion of the rational no. $\frac{43}{2^4 \cdot 5^3}$ will terminate after how many of decimals?
Ans. After 4 places of decimal.
4. Find the ($HCF \times LCM$) for the numbers 100 and 190.

Ans. 19000

5. State whether the number $(\sqrt{2} - \sqrt{3})(\sqrt{2} + \sqrt{3})$ is rational or irrational justify.

Ans. Rational

6. Write one rational and one irrational number lying between 0.25 and 0.32.

Ans. One rational no. = 0.26, one irrational no. = 0.27010010001.....

7. Express 107 in the form of $4q + 3$ for some positive integer.

Ans. $4 \times 26 + 3$

8. Write whether the rational number $\frac{51}{1500}$ will have a terminating decimal expansion or a non terminating repeating decimal expansion.

Ans. Terminating.

(level - 2)

1. Use Euclid's division algorithm to find the HCF of 1288 and 575.

Ans. 23.

2. Check whether $5 \times 3 \times 11 + 11$ and $5 \times 7 + 7 \times 3 + 3$ are composite number and justify.

Ans. Composite number.

3. Check whether 6^n can end with the digit 0, where n is any natural number.

Ans. No, 6^n can not end with the digit 0.

4. Given that $\text{LCM}(26, 169) = 338$, write $\text{HCF}(26, 169)$.]

Ans. 13

5. Find the HCF and LCM of 6, 72 and 120 using the prime factorization method.

Ans. HCF = 6
LCM = 360

(level - 3)

1. Show that $\sqrt{3}$ is an irrational number.

2. Show that $5 + 3\sqrt{2}$ is an irrational number.

3. Show that square of an odd positive integer is of the form $8m + 1$, for some integer m.

4. Find the LCM & HCF of 26 and 91 and verify that $\text{LCM} \times \text{HCF} = \text{product of the two numbers}$.

Ans. LCM=182, HCF=13

(PROBLEMS FOR SELF EVALUATION/HOTS)

1. State the fundamental theorem of Arithmetic.

2. Express 2658 as a product of its prime factors.

3. Show that the square of an odd positive integers is of the form $8m + 1$ for some whole number m.

4. Find the LCM and HCF of 17, 23 and 29.

5. Prove that $\sqrt{2}$ is not a rational number.
6. Find the largest positive integer that will divide 122, 150 and 115 leaving remainder 5, 7 and 11 respectively.
7. Show that there is no positive integer n for which $\sqrt{n-1} + \sqrt{n+1}$ is rational.
8. Using prime factorization method, find the HCF and LCM of 72, 126 and 168. Also show that $HCF \times LCM \neq \text{product of the three numbers}$.

2. Polynomials (Key Points)

Polynomial:

An expression of the form $p(x) = a_0 + a_1x + a_2x^2 + \dots + a_nx^n$ where $a_n \neq 0$ is called a polynomial in variable x of degree n . where; a_0, a_1, \dots, a_n are real numbers and each power of x is a non negative integer.

Ex.:- $2x^2 - 5x + 1$ is a polynomial of degree 2.

Note: $\sqrt{x} + 3$ is not a polynomial.

- A polynomial $p(x) = ax + b$ of degree 1 is called a linear polynomial. Ex. $5x - 3, 2x$ etc
- A polynomial $p(x) = ax^2 + bx + c$ of degree 2 is called a quadratic polynomial. Ex. $2x^2 + x - 1, 1 - 5x + x^2$ etc.
- A polynomial $p(x) = ax^3 + bx^2 + cx + d$ of degree 3 is called a cubic polynomial. Ex. $\sqrt{3}x^3 - x + \sqrt{5}, x^3 - 1$ etc.

Zeroes of a polynomial: A real number k is called a zero of polynomial $p(x)$ if $p(x) = 0$. The graph of $y = p(x)$ intersects the X- axis.

- A linear polynomial has only one zero.
- A Quadratic polynomial has two zeroes.
- A Cubic polynomial has three zeroes.

For a quadratic polynomial: If α, β are zeroes of $P(x) = ax^2 + bx + c$ then :

1. Sum of zeroes = $\alpha + \beta = \frac{-b}{a} = \frac{\text{-Coefficient of } x}{\text{coefficient of } x^2}$
2. Product of zeroes = $\alpha \cdot \beta = \frac{c}{a} = \frac{\text{Constant term}}{\text{coefficient of } x^2}$

- A quadratic polynomial whose zeroes are α and β , is given by:

$$p(x) = x^2 - (\alpha + \beta)x + \alpha\beta$$

$$= x^2 - (\text{sum of zeroes})x + \text{product of zeroes.}$$
- If α, β and γ are zeroes of the cubic polynomial $ax^3 + bx^2 + cx + d$ then:
 - * $\alpha + \beta + \gamma = \frac{-b}{a}$
 - * $\alpha\beta + \beta\gamma + \gamma\alpha = \frac{c}{a}$
 - * $\alpha\beta\gamma = \frac{-d}{a}$

Division algorithm for polynomials: If $p(x)$ and $g(x)$ are any two polynomials with $g(x) \neq 0$, then we can find polynomials $q(x)$ and $r(x)$ such that:

$p(x) = q(x) \times g(x) + r(x)$, where $r(x) = 0$ or degree of $r(x) <$ degree of $g(x)$.

(Level - 1)

1. In a graph of $y = p(x)$, find the number of zeroes of $p(x)$.

Ans. 3.

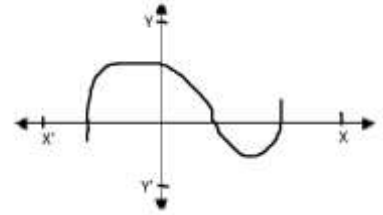

2. If α, β are the zeroes of $f(x) = x^2 + x + 1$, then find $\frac{1}{\alpha} + \frac{1}{\beta}$.

Ans. (-1)

3. Find a quadratic polynomial whose zeroes are $\frac{-2}{\sqrt{3}}$ and $\frac{\sqrt{3}}{4}$.

Ans. $x^2 - \left(\frac{-2}{\sqrt{3}} + \frac{\sqrt{3}}{4}\right)x + \left(-\frac{1}{2}\right)$

4. If $p(x) = \frac{1}{3}x^2 - 5x + \frac{3}{2}$ then find its sum and product of zeroes.

Ans. Sum=15, Product = $\frac{9}{2}$

5. If the sum of zeroes of a given polynomial $f(x) = x^3 - 3kx^2 - x + 30$ is 6. Find the value of K.

Ans. $\alpha + \beta + \gamma = \frac{-b}{a} = \frac{3k}{1} = 6$
 $\therefore k = 2$

6. Find the zero of polynomial $3x + 4$.

Ans. -4/3

7. Write the degree of zero polynomial.

Ans. Not defined.

(Level - 2)

1. Form a cubic polynomial with zeroes 3, 2 and -1.

Hints/Ans. $p(x) = x^3 - (\alpha + \beta + \gamma)x^2 + (\alpha\beta + \beta\gamma + \gamma\alpha)x - \alpha\beta\gamma$

2. Find the zeroes of the quadratic polynomial $6x^2 - 3 - 7x$ and verify the relationship between the zeroes and the coefficients.

Ans. Zeroes are 3/2 & -1/3.

3. For what value of k, (-4) is a zero of polynomial $x^2 - x - (2k + 2)$?

Ans. k=9

4. Give an example of polynomials

$p(x), g(x), q(x)$ and $r(x)$ which satisfy division algorithm and $\text{deg. } p(x) = \text{deg. } g(x)$.

Ans. $3x^2 + 2x + 1, x^2, 3, 2x + 1$

5. Find the zeroes of $4u^2 + 8u$.

Ans. 0, -2

6. Find a quadratic polynomial, whose the sum and product of its zeroes are $\frac{1}{4}, -1$.

Ans. $x^2 - \frac{1}{4}x - 1$

(Level - 3)

1. Find the zeroes of polynomial $x^3 - 2x^2 - x + 2$

Ans. -1, 1, 2

2. If the zeroes of the polynomial $x^3 - 3x^2 + x + 1$ are $\alpha - \beta, \alpha, \alpha + \beta$. Find α and β

Ans. $\alpha = 1, \beta = \pm\sqrt{2}$

3. Divide $f(x) = 6x^3 + 11x^2 - 39x - 65$ by $g(x) = x^2 - 1 + x$

Ans. Quotient= $6x + 5$; Remainder = $-38x - 60$

4. Check whether the polynomial $t^2 - 3$ is a factor of polynomial $2t^4 + 3t^3 - 2t^2 - 9t - 12$ by applying the division algorithm.

Ans. Remainder=0, Quotient= $2t^2 + 3t + 4$, Given Polynomial is a factor.

(Level - 4)

1. Obtain all zeroes of $f(x) = x^3 + 13x^2 + 32x + 20$

Ans. -1, -2, -10

2. Obtain all other zeroes of $3x^4 + 6x^3 - 2x^2 - 10x - 5$, if two of its zeroes are $\sqrt{\frac{5}{3}}$ and $-\sqrt{\frac{5}{3}}$

Ans. -1 & -1

3. On dividing $x^3 - 3x^2 + x + 2$ by a polynomial $g(x)$, the quotient and remainder were $x - 2$ and $-2x + 4$ respectively, find $g(x)$.

Ans. $x^2 - x + 1$

(PROBLEMS FOR SELF-EVALUATION)

1. Check whether $g(x) = 3x - 2$ is a factor of $p(x) = 3x^3 + x^2 - 20x + 12$.

2. Find quotient and remainder applying the division algorithm on dividing $p(x) = x^3 - 6x^2 + 2x - 4$ by $g(x) = x - 1$.

3. Find zeros of the polynomial $2x^2 - 8x + 6$

4. Find the quadratic polynomial whose sum and product of its zeros are $\frac{2}{3}$, $\frac{-1}{3}$ respectively.

5. Find the zeroes of polynomial $x^3 - 2x^2 - x + 2$

6. If one of the zeroes of the polynomial $2x^2 + px + 4 = 0$ is 2, find the other root, also find the value of p.

7. If α and β are the zeroes of the polynomial $kx^2 + 4x + 4$ show that $\alpha^2 + \beta^2 = 24$, find the value of k.

8. If α and β are the zeroes of the equation $6x^2 + x - 2 = 0$, find $\frac{\alpha}{\beta} + \frac{\beta}{\alpha}$

---XXX---

3. Pair of linear equations in two variables

(Key Points)

- An equation of the form $ax + by + c = 0$, where a, b, c are real nos ($a \neq 0, b \neq 0$) is called a linear equation in two variables x and y .

Ex : (i) $x - 5y + 2 = 0$

(ii) $\frac{3}{2}x - y = 1$

- The general form for a pair of linear equations in two variables x and y is

$$a_1x + b_1y + c_1 = 0$$

$$a_2x + b_2y + c_2 = 0$$

where $a_1, b_1, c_1, a_2, b_2, c_2$ are all real nos and $a_1 \neq 0, b_1 \neq 0, a_2 \neq 0, b_2 \neq 0$.

Examples: $x + 3y - 6 = 0$

$$2x - 3y - 12 = 0$$

- Graphical representation of a pair of linear equations in two variables:

$$a_1x + b_1y + c_1 = 0$$

$$a_2x + b_2y + c_2 = 0$$

- (i) will represent intersecting lines if $\frac{a_1}{a_2} \neq \frac{b_1}{b_2}$

i.e. unique solution. And this type of equations are called consistent pair of linear equations.

Ex: $x - 2y = 0$

$$3x + 4y - 20 = 0$$

- (ii) will represent overlapping or coincident lines if $\frac{a_1}{a_2} = \frac{b_1}{b_2} = \frac{c_1}{c_2}$

i.e. Infinitely many solutions, consistent or dependent pair of linear equations

Ex: $2x + 3y - 9 = 0$

$$4x + 6y - 18 = 0$$

- (iii) will represent parallel lines if $\frac{a_1}{a_2} = \frac{b_1}{b_2} \neq \frac{c_1}{c_2}$

i.e. no solution and called inconsistent pair of linear equations

Ex: $x + 2y - 4 = 0$

$$2x + 4y - 12 = 0$$

- (iv) Algebraic methods of solving a pair of linear equations:

- (i) Substitution method
- (ii) Elimination Method
- (iii) Cross multiplication method

(Level - 1)

1. Find the value of 'a' so that the point(3,9) lies on the line represented by $2x-3y=5$

Ans: $a = \frac{1}{3}$

2. Find the value of k so that the lines $2x - 3y = 9$ and $kx - 9y = 18$ will be parallel.

Ans: $k = 6$

3. Find the value of k for which $x + 2y = 5, 3x + ky + 15 = 0$ is inconsistent

Ans: $k=6$

4. Check whether given pair of lines is consistent or not $5x - 1 = 2y$, $y = \frac{-1}{2} + \frac{5}{2}x$

Ans: consistent

5. Determine the value of 'a' if the system of linear equations $3x+2y -4 =0$ and $9x - y - 3 = 0$ will represent intersecting lines.

Ans: $a \neq \frac{-3}{2}$

6. Write any one equation of the line which is parallel to $\sqrt{2}x - \sqrt{3}y = 5$

Ans: $5\sqrt{2}x - 5\sqrt{3}y = 5\sqrt{5}$

7. Find the point of intersection of line $-3x + 7y = 3$ with x-axis

Ans: $(-1, 0)$

8. For what value of k the following pair has infinite number of solutions.

$$(k-3)x + 3y = k$$

$$k(x+y)=12$$

Ans: $k=6$

9. Write condition so that $a_1x + b_1y = c_1$ and $a_2x + b_2y = c_2$ have unique solution.

Ans: $\frac{a_1}{a_2} \neq \frac{b_1}{b_2}$

(Level - 2)

1. 5 pencils and 7pens together cost Rs. 50 whereas 7 pencils and 5 pens together cost Rs. 46. Find the cost of one pencil and that of one pen.

Ans: Cost of one pencil = Rs. 3

Cost of one pen = Rs. 5

2. Solve the equations:

$$3x - y = 3$$

$$7x + 2y = 20$$

Ans: $x=2, y=3$

3. Find the fraction which becomes to $\frac{2}{3}$ when the numerator is increased by 2 and equal to $\frac{4}{7}$ when the denominator is increased by 4

Ans: $\frac{28}{45}$

4. Solve the equation:

$$px + qy = p - q$$

$$qx - py = p + q$$

Ans: $x = 1, y = -1$

(Level - 3)

1. Solve the equation using the method of substitution:

$$3x - 5y = -1$$

$$x - y = -1$$

$$\text{Ans. } x = -2, y = -1$$

2. Solve the equations:

$$\frac{1}{2x} - \frac{1}{y} = -1$$

$$\frac{1}{x} + \frac{1}{2y} = 8 \quad \text{Where, } x \neq 0, y \neq 0$$

$$\text{Ans. } x = \frac{1}{6}, y = \frac{1}{4}$$

3. Solve the equations by using the method of cross multiplication:

$$x + y = 7$$

$$5x + 12y = 7$$

$$\text{Ans. } x = 11, y = -4$$

4. A man has only 20 paise coins and 25 paise coins in his purse, If he has 50 coins in all totaling Rs. 11.25, how many coins of each kind does he have.

$$\text{Ans. 25 coins of each kind}$$

5. For what value of k, will the system of equations

$$x + 2y = 5$$

$$3x + ky - 15 = 0 \text{ has a unique solution.}$$

$$\text{Ans. } k \neq 6$$

(level - 4)

1. Draw the graphs of the equations

$$4x - y = 4$$

$$4x + y = 12$$

Determine the vertices of the triangle formed by the lines representing these equations and the x-axis. Shade the triangular region so formed

$$\text{Ans: } (2,4)(1,0)(3,0)$$

2. Solve Graphically

$$x - y = -1 \text{ and}$$

$$3x + 2y = 12$$

Calculate the area bounded by these lines and the x-axis,

$$\text{Ans: } x = 2, y = 3 \text{ and area} = 7.5 \text{ unit}^2$$

3. Solve :- $\frac{10}{x+y} + \frac{2}{x-y} = 4$

$$\frac{15}{x+y} + \frac{5}{x-y} = -2$$

Ans: $x = 3, y = 2$

4. Ritu can row downstream 20 km in 2 hr, and upstream 4 km in 2 hr. find her speed of rowing in still water and the speed of the current. (HOTS)

Ans: Speed of the rowing in still water = 6 km/hr

Speed of the current = 4 km/hr.

5. In a ΔABC , $\angle C = 3$, $\angle B = 2(\angle A + \angle B)$ find these angles. (HOTS)

Ans: $\angle a = 20^\circ, \angle b = 40^\circ, \angle c = 120^\circ$.

6. 8 men and 12 boys can finish a piece of work in 10 days while 6 men and 8 boys can finish it in 14 days. Find the time taken by 1 man alone and that by one boy alone to finish the work. (HOTS)

Ans: One man can finish work in 140 days

One boy can finish work in 280 days

7. Find the value of K for which the system of linear equations $2x+5y = 3$, $(k+1)x + 2(k+2)y = 2K$ will have infinite number of solutions.

(HOTS)

Ans: $K = 3$

(SELF EVALUATION/HOTS)

1. Solve for x and y:

$$x + y = a + b$$

$$ax - by = a^2 - b^2$$

2. For what value of k will the equation $x + 5y - 7 = 0$ and $4x + 20y + k = 0$ represent coincident lines?

3. Solve graphically: $3x + y + 1 = 0$

$$2x - 3y + 8 = 0$$

4. The sum of digits of a two digit number is 9. If 27 is subtracted from the number, the digits are reversed. Find the number.

5. Draw the graph of $x + 2y - 7 = 0$ and $2x - y - 4 = 0$. Shade the area bounded by these lines and Y-axis.

6. Students of a class are made to stand in rows. If one student is extra in a row, there would be 2 rows less. If one student is less in a row there would be 3 rows more. Find the number of the students in the class.

7. A man travels 370 km partly by train and partly by car. If he covers 250 km by train and the rest by the car it takes him 4 hours, but if he travels 130 km by train and the rest by car, he takes 18 minutes longer. Find the speed of the train and that of the car

8. Given linear equation $2x + 3y - 8 = 0$, write another linear equation such that the geometrical representation of the pair so formed is (i) intersecting lines, (ii) Parallel Lines.

TRIANGLES

KEY POINTS

1. **Similar Triangles:-** Two triangles are said to be similar, if (a) their corresponding angles are equal and (b) their corresponding sides are in proportion (or are in the same ratio).
2. Basic proportionality Theorem [or Thales theorem].
3. Converse of Basic proportionality Theorem.
4. Criteria for similarity of Triangles.
 - (a) AA or AAA similarity criterion.
 - (b) SAS similarity criterion.
 - (c) SSS similarity criterion.
5. Areas of similar triangles.
6. Pythagoras theorem.
7. Converse of Pythagoras theorem.

(Level -1)

1. If in two triangles, corresponding angles are equal, then the two triangles are.....
Ans. Equiangular then similar
2. ΔABC is a right angled at B. BD is perpendicular upon AC. If $AD=a$, $CD=b$, then $AB^2=$
Ans. $a(a+b)$
3. The area of two similar triangles are 32cm^2 and 48cm^2 . If the square of a side of the first Δ is 24cm^2 , then the square of the corresponding side of 2nd triangle will be
Ans. 36cm^2
4. ABC is a triangle with $DE \parallel BC$. If $AD=2\text{cm}$, $BD=4\text{cm}$ then find the value DE:BC
Ans. 1:3
5. In ΔABC , $DE \parallel BC$, if $AD=4x-3$, $DB=3x-1$, $AE=8x-7$ and $BC=5x-3$, then find the values of x are:
Ans. $1, -\frac{1}{2}$
6. The perimeters of two similar triangles are 40cm and 50 cm respectively, find the ratio of the area of the first triangle to the area of the 2nd triangle:
Ans. 16:25
7. A man goes 150m due east and then 200m due north. How far is he from the starting point?
Ans. 250 m
8. A ladder reaches a window which is 12m above the ground on one side of the street. Keeping its foot at the same point, the ladder is turned to the other side of the street to reach a window 9m high. If the length of the ladder is 15m, find the width of the street.
Ans. 21m

9. BO and CO are respectively the bisector of $\angle B$ and $\angle C$ of ΔABC . AO produced meets BC at P, then find AB/AC

Ans. $\frac{BP}{PC}$

10. In ΔABC , the bisectors of $\angle B$ intersect the side AC at D. A line parallel to side AC intersects line segments AB, DB and CB at points P, R, Q respectively. Then, Find AB X CQ

Ans. BC X AP

11. If ΔABC is an equilateral triangle such that $AD \perp BC$, then $AD^2 = \dots\dots\dots$

Ans. $3CD^2$

12. If ΔABC and ΔDEF are similar triangles such that $\angle A = 47^\circ$, and $\angle E = 83^\circ$, then find $\angle C$

Ans. 50°

13. Two isosceles triangles have equal angles and their areas are in the ratio 16:25, then find the ratio of their corresponding heights

Ans. 4:5

14. Two poles of heights 6m and 11m stand vertically upright on a plane ground. If the distance between their feet is 12m, then find the distance between their tops.

Ans. 13m

15. The lengths of the diagonals of a rhombus are 16cm and 12cm. Then, find the length of the side of the rhombus .

Ans. 10cm

(Level - 2)

1. In given fig. $BD \perp AC$ and $CE \perp AB$ then prove that

(a) $\Delta AEC \sim \Delta ADB$

(b) $CA/AB = CE/DB$

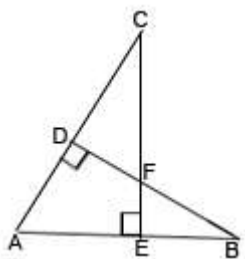

2. In the given figure fig $\frac{PS}{SQ} = \frac{PT}{TR}$, and $\angle PST = \angle PQR$. Prove that ΔPQR is an isosceles triangle.

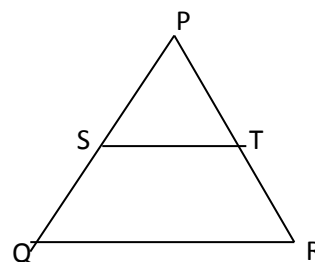

3. In given fig $AD \perp BC$ and $\angle B < 90^\circ$, prove that $AC^2 = AB^2 + BC^2 - 2BC \times BD$

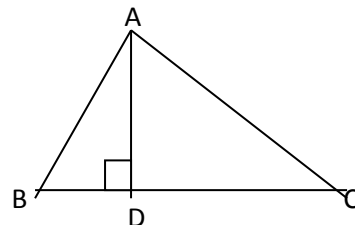

4. In given fig. ΔABC is right angled at C and $DE \perp AB$. Prove that $\Delta ABC \sim \Delta ADE$ and hence find length of AE and DE.

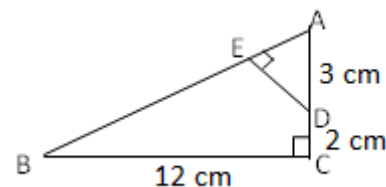

Ans. $\frac{15}{17}, \frac{36}{17}$

5. In a ΔABC , if $DE \parallel AC$ and $DF \parallel AE$, prove that $\frac{EF}{BF} = \frac{EC}{BE}$

6. In given fig. $AD \perp BC$, if $\frac{BD}{AD} = \frac{DA}{DC}$, prove that ABC is a right angled triangle.

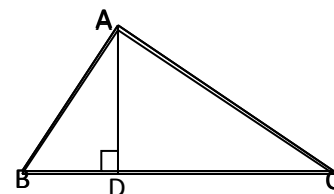

7. Two Δ s ABC and DEF are similar. If $ar(\Delta DEF) = 243 \text{ cm}^2$, $ar(\Delta ABC) = 108 \text{ cm}^2$ and $BC = 6 \text{ cm}$, find EF.

Ans. 9 cm

8. What is the value of K in given figure if $DE \parallel BC$.

Ans. $K=4, -1$

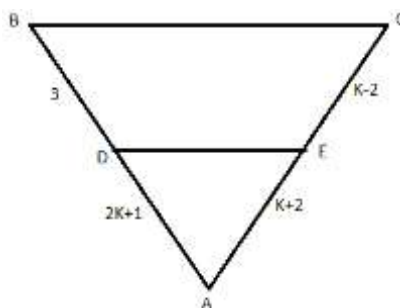

9. A pole of length 10m casts a shadow 2m long on the ground. At the same time a tower casts a shadow of length 60m on the ground then find the height of the tower.

Ans. 300m

Level - 3

1. In given figure, $AB \parallel DC$ and $\frac{AO}{OC} = \frac{BO}{OD}$ then find the value of x, if $OA = 2x + 7, OB = 4x, OD = 4x - 4$ and $OC = 2x + 4$

Ans. 7

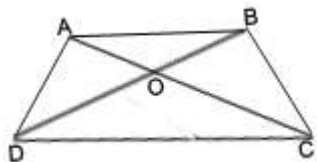

2. PQR is a right angled triangle with $\angle P=90^\circ$. If $PM \perp QR$, then show that $PM^2 = QM \times MR$

3. In given fig. $\frac{QR}{QS} = \frac{QT}{PR}$ and $\angle 1 = \angle 2$. Show that $\Delta PQS \sim \Delta TQR$.

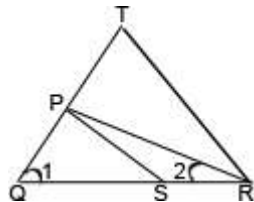

4. Find the length of altitude of an equilateral triangle of side 2cm.

Ans. $\sqrt{3}$ cm

5. In a trapezium ABCD, O is the point of intersection of AC and BD, $AB \parallel CD$ and $AB=2CD$. If the area of $\Delta AOB=84\text{cm}^2$ then find area of ΔCOD .

Ans. 21 cm^2

6. In given fig. $\frac{PS}{SQ} = \frac{PT}{TR} = 3$. If area of ΔPQR is 32cm^2 , then find the area of the quad. STQR

Ans. 14 cm^2

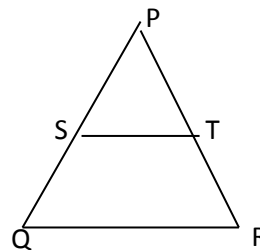

7. M is the mid-point of the side CD of a $\parallel\text{gm}$ ABCD. The line BM is drawn intersecting AC at L and AD produced at E. Prove that $EL=2BL$.

8. Prove that the ratio of the area of two similar Δ s is equal to the square of the ratio of their corresponding medians.

9. D and E are points on the sides CA and CB respectively of ΔABC , right angled at C. Prove that $AE^2 + BD^2 = AB^2 + DE^2$.

10. ABC and DBC are two Δ s on the same base BC and on the same side of BC with $\angle A = \angle D = 90^\circ$. If CA and BD meet each other at E, show that $AE \times EC = BE \times ED$.

1. Prove that in a right angled triangle the square of hypotenuse is equal to the sum of the squares of the other two sides.

2. If a line is drawn parallel to one side of a triangle to intersect the other two sides in distinct points, prove that the other two sides are divided into the same ratio.

3. ΔABC is right angled at B and D is midpoint of side BC. Prove that $AC^2 = 4AD^2 - 3AB^2$

4. Prove that the ratio of the areas of two similar triangles is equal to the ratio of square of their corresponding sides.

5. In a Δ , if the square of one side is equal to sum of the squares of the other two sides, prove that the angle opposite to the first side is a right angle.

6. In an equilateral ΔABC , D is a point on the side BC, such that $BD = \frac{1}{3}BC$. Prove that $9AD^2 = 7AB^2$

7. P and Q are the mid points of side CA and CB respectively of ΔABC right angled at C. Prove that $4(AQ^2 + BP^2) = 5AB^2$.

8. CM and RN are respectively the medians of ΔABC and ΔPQR . If $\Delta ABC \sim \Delta PQR$, prove that

(i) $\Delta AMC \sim \Delta PNR$

(ii) $CM/RN = AB/PQ$

(iii) $\Delta CMB \sim \Delta RNQ$

SELF EVALUATION

1. The diagonal BD of a ||gm ABCD intersects the line segment AE at the point F, where E is any point on the side BC. Prove that $DF \times EF = FB \times FA$.

2. In fig. $DB \perp BC$, $DE \perp AB$ and $AC \perp BC$. Prove that $BE/DE = AC/BC$.

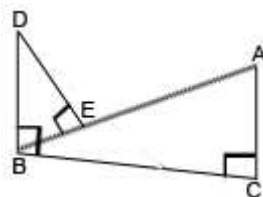

3. In given fig. PA, QB, RC are each perpendicular to AC. Prove that $\frac{1}{x} + \frac{1}{z} = \frac{1}{y}$

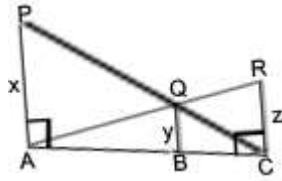

4. Prove that three times the sum of the squares of the sides of a triangle is equal to four times the sum of the squares of the medians of the triangle.

5. ABC is a right triangle with $\angle A = 90^\circ$, A circle is inscribed in it. The lengths of the two sides containing the right angle are 6 cm and 8 cm. find the radius of the incircle. Ans. 4cm

6. ABC is a right triangle, right angled at C. If p is the length of the perpendicular from C to AB and a, b, c have the usual meaning, then prove that

(i) $cp=ab$ (ii) $\frac{1}{p^2} = \frac{1}{a^2} + \frac{1}{b^2}$

7. In a trapezium ABCD, $AB \parallel DC$ and $DC=2AB$. $EF \parallel AB$, where E and F lie on the side BC and AD respectively such that $BE/EC=4/3$. Diagonal DB intersects EF at G. Prove that $EF=11AB$.

8. Sides AB, AC and median AD of a triangle ABC are respectively proportional to sides PQ, PR and median PM of another triangle PQR. Show that $\Delta ABC \sim \Delta PQR$.

INTRODUCTION TO TRIGONOMETRY

IMPORTANT CONCEPTS

TAKE A LOOK:

1. Trigonometric ratios of an acute angle of a right angled triangle.

$$\sin \theta = \frac{\text{Side opposite to } \angle \theta}{\text{Hypotenuse}} = \frac{BC}{AC}$$

$$\cos \theta = \frac{\text{Side adjacent to } \angle \theta}{\text{Hypotenuse}} = \frac{AB}{AC}$$

$$\tan \theta = \frac{\text{Side opposite to } \angle \theta}{\text{Side adjacent to } \angle \theta} = \frac{BC}{AB}$$

$$\cot \theta = \frac{1}{\tan \theta} = \frac{\text{Side Adjacent to } \angle \theta}{\text{Side Opposite to } \angle \theta} = \frac{AB}{BC}$$

$$\sec \theta = \frac{1}{\cos \theta} = \frac{\text{Hypotenuse}}{\text{Side adjacent to } \angle \theta} = \frac{AC}{AB}$$

$$\operatorname{cosec} \theta = \frac{1}{\sin \theta} = \frac{\text{Hypotenuse}}{\text{side Opposite to } \angle \theta} = \frac{AC}{BC}$$

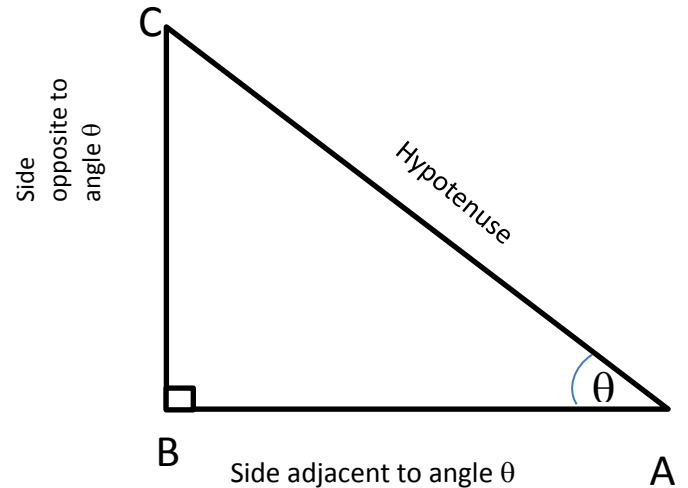

2. Relationship between different trigonometric ratios

$$\tan \theta = \frac{\sin \theta}{\cos \theta}$$

$$\cot \theta = \frac{\cos \theta}{\sin \theta}$$

$$\tan \theta = \frac{1}{\cot \theta}$$

$$\cos \theta = \frac{1}{\sec \theta}$$

$$\sin \theta = \frac{1}{\operatorname{cosec} \theta}$$

3. Trigonometric Identities.

- (i) $\sin^2 \theta + \cos^2 \theta = 1$
- (ii) $1 + \tan^2 \theta = \sec^2 \theta$
- (iii) $1 + \cot^2 \theta = \operatorname{cosec}^2 \theta$

4. Trigonometric Ratios of some specific angles.

θ	0°	30°	45°	60°	90°
$\sin \theta$	0	$\frac{1}{2}$	$\frac{1}{\sqrt{2}}$	$\frac{\sqrt{3}}{2}$	1
$\cos \theta$	1	$\frac{\sqrt{3}}{2}$	$\frac{1}{\sqrt{2}}$	$\frac{1}{2}$	0
$\tan \theta$	0	$\frac{1}{\sqrt{3}}$	1	$\sqrt{3}$	Not defined
$\cot \theta$	Not defined	$\sqrt{3}$	1	$\frac{1}{\sqrt{3}}$	0
$\sec \theta$	1	$\frac{2}{\sqrt{3}}$	$\sqrt{2}$	2	Not defined
$\operatorname{cosec} \theta$	Not defined	2	$\sqrt{2}$	$\frac{2}{\sqrt{3}}$	1

5. Trigonometric ratios of complementary angles.

- (i) $\sin(90^\circ - \theta) = \cos \theta$
- (ii) $\cos(90^\circ - \theta) = \sin \theta$
- (iii) $\tan(90^\circ - \theta) = \cot \theta$
- (iv) $\cot(90^\circ - \theta) = \tan \theta$
- (v) $\sec(90^\circ - \theta) = \operatorname{cosec} \theta$
- (vi) $\operatorname{cosec}(90^\circ - \theta) = \sec \theta$

(Level – 1)

1. If θ and $3\theta - 30^\circ$ are acute angles such that $\sin \theta = \cos(3\theta - 30^\circ)$, then find the value of $\tan \theta$.

Ans. $\frac{1}{\sqrt{3}}$

2. Find the value of $\frac{(\cos 30^\circ + \sin 60^\circ)}{(1 + \cos 60^\circ + \sin 30^\circ)}$

Ans. $2\sqrt{3}$

3. Find the value of $(\sin \theta + \cos \theta)^2 + (\cos \theta - \sin \theta)^2$

Ans. 2

4. If $\tan \theta = \frac{3}{4}$ then find the value of $\cos^2 \theta - \sin^2 \theta$

Ans. $\frac{7}{25}$

5. If $\sec \theta + \tan \theta = p$, then find the value of $\sec \theta - \tan \theta$

Ans. $\frac{1}{p}$

6. change $\sec^4 \theta - \sec^2 \theta$ in terms of $\tan \theta$.

Ans. $\tan^4 \theta + \tan^2 \theta$

7. If $\cot \theta = 1/\sqrt{3}$ then find the value of $(1 - \cos^2 \theta)/(1 + \cos^2 \theta)$

Ans. $\frac{3}{5}$

8. If $\cot \theta + \frac{1}{\cot \theta} = 2$ then find the value of $\cot^2 \theta + \frac{1}{\cot^2 \theta}$.

Ans. 2

9. If $\sin \theta = a/b$, then find the value of $\sec \theta + \tan \theta$

Ans. $\sqrt{\frac{b+a}{b-a}}$

10. If $\cos x = \cos 60^\circ \cos 30^\circ + \sin 60^\circ \sin 30^\circ$, then find the value of x

Ans. 30°

11. If $0^\circ \leq x \leq 90^\circ$ and $2\sin^2 x = 1/2$, then find the value of x

Ans. 30°

12. Find the value of $\operatorname{cosec}^2 30^\circ - \sin^2 45^\circ - \sec^2 60^\circ$

Ans. -2

13. Simplify $(\sec \theta + \tan \theta)(1 - \sin \theta)$

Ans. $\cos \theta$

Level - 2

1. If $\sec\alpha=5/4$ then evaluate $\tan\alpha/(1+\tan^2\alpha)$.

Ans: $\frac{12}{25}$

2. If $A+B=90^\circ$, then prove that $\sqrt{\frac{\tan A \tan B + \tan A \cot B}{\sin A \sec B} - \frac{\sin^2 B}{\cos^2 B}} = \tan A$

3. Prove that $\cos A/(1-\sin A) + \cos A/(1+\sin A) = 2\sec A$.

4. Prove that $\sqrt{\frac{\sec A - 1}{\sec A + 1}} + \sqrt{\frac{\sec A + 1}{\sec A - 1}} = 2\operatorname{cosec} A$

5. Prove that $(\sin\theta + \operatorname{cosec}\theta)^2 + (\cos\theta + \sec\theta)^2 = 7 + \tan^2\theta + \cot^2\theta$.

6. Evaluate $\frac{11\sin 70^\circ}{7\cos 20^\circ} - \frac{4\cos 53^\circ \operatorname{cosec} 37^\circ}{7\tan 15^\circ \tan 35^\circ \tan 55^\circ \tan 75^\circ}$ Ans:1

7. Prove that $\sqrt{\frac{\operatorname{cosec} A - 1}{\operatorname{cosec} A + 1}} + \sqrt{\frac{\operatorname{cosec} A + 1}{\operatorname{cosec} A - 1}} = 2\sec A$.

8. In a right angle triangle ABC, right angled at B, if $\tan A=1$, then verify that $2\sin A \cos A = 1$.

9. If $\tan(A-B)=\sqrt{3}$, and $\sin A = 1/2$, then find A and B. Ans: 90° & 30°

10. If θ is an acute angle and $\sin\theta = \cos\theta$, find the value of $3\tan^2\theta + 2\sin^2\theta - 1$. Ans:3

11. If $\frac{x}{a}\cos\theta + \frac{y}{b}\sin\theta = 1$ and $\frac{x}{a}\sin\theta - \frac{y}{b}\cos\theta = 1$, prove that $x^2/a^2 + y^2/b^2 = 2$.

Level - 3

1. Evaluate the following :- $\sin^2 25^\circ + \sin^2 65^\circ + \sqrt{3}(\tan 5^\circ \tan 15^\circ \tan 30^\circ \tan 75^\circ \tan 85^\circ)$.

Ans:2

2. If $\frac{\cos\alpha}{\cos\beta} = m$, and $\frac{\cos\alpha}{\sin\beta} = n$, show that $(m^2+n^2) \cos^2\beta = n^2$.

3. Prove that $\tan^2\theta + \cot^2\theta + 2 = \operatorname{cosec}^2\theta \sec^2\theta$.

4. Prove that $(\tan A - \tan B)^2 + (1 + \tan A \tan B)^2 = \sec^2 A \sec^2 B$.

5. If $(\cos\theta - \sin\theta) = \sqrt{2} \sin\theta$, then show that $\cos\theta + \sin\theta = \sqrt{2} \cos\theta$.

6. Prove that $(\sin\theta + \sec\theta)^2 + (\cos\theta + \operatorname{cosec}\theta)^2 = (1 + \sec\theta \operatorname{cosec}\theta)^2$.

7. Prove that $\sin\theta/(1-\cos\theta) + \tan\theta/(1+\cos\theta) = \sec\theta\operatorname{cosec}\theta + \cot\theta$.

8. Prove that $(\sin\theta - \operatorname{cosec}\theta)(\cos\theta - \sec\theta) = \frac{1}{\tan\theta + \cot\theta}$.

9. If $\cot\theta = \frac{15}{8}$, evaluate $(2 + 2\sin\theta)(1 - \sin\theta)/(1 + \cos\theta)(2 - 2\sin\theta)$.

Level - 4

1. Prove that $(\sec\theta + \tan\theta - 1)/(\tan\theta - \sec\theta + 1) = \cos\theta/(1 - \sin\theta)$.

2. If $x = r \sin A \cos C$, $y = r \sin A \sin C$, $z = r \cos A$, Prove that $r^2 = x^2 + y^2 + z^2$.

3. Prove that $\frac{1}{\sec\theta - \tan\theta} - \frac{1}{\cos\theta} = \frac{1}{\cos\theta} - \frac{1}{\sec\theta + \tan\theta}$.

4. If $x = a \sin\theta$, $y = b \tan\theta$, prove that $\frac{a^2}{x^2} - \frac{b^2}{y^2} = 1$.

5. Prove that: $\frac{\cos\theta}{1 - \tan\theta} - \frac{\sin^2\theta}{\sin\theta - \cos\theta} = \sin\theta + \cos\theta$

6. Evaluate $\frac{\sin^2\theta + \sin^2(90^\circ - \theta)}{3(\sec^2 61^\circ - \cot^2 29^\circ)} - \frac{3\cot^2 30^\circ \sin^2 54^\circ \sec^2 36^\circ}{2(\operatorname{cosec}^2 65^\circ - \tan^2 25^\circ)}$. Ans. $-\frac{25}{6}$

7. Prove that $\frac{1 + \cos A + \sin A}{1 + \cos A - \sin A} = \frac{1 + \sin A}{\cos A}$.

8. Prove that $\frac{\sin\theta - 2\sin^3\theta}{2\cos^3\theta - \cos\theta} = \tan\theta$.

9. Prove that $\frac{1 + \tan^2 A}{1 + \cot^2 A} = \left(\frac{1 - \tan A}{1 - \cot A}\right)^2 = \tan^2 A$.

10. If $\cot\theta = \frac{7}{8}$, evaluate (i) $\cos^2\theta + \sin^2\theta$ (ii) $\cos^2\theta - \sin^2\theta$. Ans. 1, $-\frac{15}{113}$

Self Evaluation

1. If $a \cos\theta + b \sin\theta = c$, then prove that $a \sin\theta - b \cos\theta = \mp \sqrt{a^2 + b^2 - c^2}$.

2. If A, B, C are interior angles of triangle ABC , show that $\operatorname{cosec}^2\left(\frac{B+C}{2}\right) - \tan^2 \frac{A}{2} = 1$.

3. If $\sin\theta + \sin^2\theta + \sin^3\theta = 1$, prove that $\cos^6\theta - 4\cos^4\theta + 8\cos^2\theta = 4$.

4. If $\tan A = n \tan B$, $\sin A = m \sin B$, prove that $\cos^2 A = \frac{m^2 - 1}{n^2 - 1}$.

5. Evaluate $[\sec \theta \operatorname{cosec}(90^\circ - \theta) - \tan \theta \cot(90^\circ - \theta) + \sin^2 55^\circ \sin^2 35^\circ] /$

$(\tan 10^\circ \tan 20^\circ \tan 60^\circ \tan 70^\circ \tan 80^\circ)$. Ans: $\frac{2}{\sqrt{3}}$

6. If $\sec \theta + \tan \theta = p$, prove that $\sin \theta = \frac{p^2 - 1}{p^2 + 1}$.

STATISTICS KEY POINTS

The three measures of central tendency are :

- i. Mean
 - ii. Median
 - iii. Mode
- Mean Of grouped frequency distribution can be calculated by the following methods.

(i) **Direct Method**

$$\text{Mean} = \bar{X} = \frac{\sum_{i=1}^n f_i x_i}{\sum_{i=1}^n f_i}$$

Where X_i is the class mark of the i^{th} class interval and f_i frequency of that class

(ii) **Assumed Mean method or Shortcut method**

$$\text{Mean} = \bar{X} = a + \frac{\sum_{i=1}^n f_i d_i}{\sum_{i=1}^n f_i}$$

Where a = assumed mean

And $d_i = X_i - a$

(iii) **Step deviation method.**

$$\text{Mean} = \bar{X} = a + \frac{\sum_{i=1}^n f_i u_i}{\sum_{i=1}^n f_i} \times h$$

Where a = assumed mean

h = class size

And $u_i = (X_i - a)/h$

- Median of a grouped frequency distribution can be calculated by

$$\text{Median} = l + \left(\frac{\frac{n}{2} - cf}{f} \right) \times h$$

Where

l = lower limit of median class

n = number of observations

cf = cumulative frequency of class preceding the median class

f = frequency of median class

h = class size of the median class.

- Mode of grouped data can be calculated by the following formula.

$$\text{Mode} = l + \left(\frac{f_1 - f_0}{2f_1 - f_0 - f_2} \right) \times h$$

Where

l = lower limit of modal class

h = size of class interval

f_1 = Frequency of the modal class

f_0 = frequency of class preceding the modal class

f_2 = frequency of class succeeding the modal class

- Empirical relationship between the three measures of central tendency.

$$3 \text{ Median} = \text{Mode} + 2 \text{ Mean}$$

$$\text{Or, Mode} = 3 \text{ Median} - 2 \text{ Mean}$$

- Ogive

Ogive is the graphical representation of the cumulative frequency distribution. It is of two types:

- (i) Less than type ogive.
- (ii) More than type ogive

- Median by graphical method
The x-coordinated of the point of intersection of 'less than ogive' and 'more than ogive' gives the median.

LEVEL – 1

S/no	Question	Ans																
1	What is the mean of 1 st ten prime numbers ?	12.9																
2	What measure of central tendency is represented by the abscissa of the point where less than ogive and more than ogive intersect?	Median																
3	If the mode of a data is 45 and mean is 27, then median is _____.	33																
4	Find the mode of the following	Mode =40																
	<table border="1"> <tr> <td>X_i</td> <td>35</td> <td>38</td> <td>40</td> <td>42</td> <td>44</td> <td></td> </tr> <tr> <td>f_i</td> <td>5</td> <td>9</td> <td>10</td> <td>7</td> <td>2</td> <td></td> </tr> </table>	X_i	35	38	40	42	44		f_i	5	9	10	7	2				
X_i	35	38	40	42	44													
f_i	5	9	10	7	2													
5	Write the median class of the following distribution.	30-40																
	<table border="1"> <tr> <td>Class</td> <td>0-10</td> <td>10-20</td> <td>20-30</td> <td>30-40</td> <td>40-50</td> <td>50-60</td> <td>60-70</td> </tr> <tr> <td>Frequency</td> <td>4</td> <td>4</td> <td>8</td> <td>10</td> <td>12</td> <td>8</td> <td>4</td> </tr> </table>	Class	0-10	10-20	20-30	30-40	40-50	50-60	60-70	Frequency	4	4	8	10	12	8	4	
Class	0-10	10-20	20-30	30-40	40-50	50-60	60-70											
Frequency	4	4	8	10	12	8	4											

LEVEL – 2

S/no	Question	Ans																
1	Calculate the mean of the following distribution	78																
	<table border="1"> <tr> <td>Class interval</td> <td>50-60</td> <td>60-70</td> <td>70-80</td> <td>80-90</td> <td>90-100</td> </tr> <tr> <td>Frequency</td> <td>8</td> <td>6</td> <td>12</td> <td>11</td> <td>13</td> </tr> </table>	Class interval	50-60	60-70	70-80	80-90	90-100	Frequency	8	6	12	11	13					
Class interval	50-60	60-70	70-80	80-90	90-100													
Frequency	8	6	12	11	13													
2	Find the mode of the following frequency distribution	33.33																
	<table border="1"> <tr> <td>Marks</td> <td>10-20</td> <td>20-30</td> <td>30-40</td> <td>40-50</td> <td>50-60</td> </tr> <tr> <td>No. of students</td> <td>12</td> <td>35</td> <td>45</td> <td>25</td> <td>13</td> </tr> </table>	Marks	10-20	20-30	30-40	40-50	50-60	No. of students	12	35	45	25	13					
Marks	10-20	20-30	30-40	40-50	50-60													
No. of students	12	35	45	25	13													
3	Find the median of the following distribution	28.5																
	<table border="1"> <tr> <td>Class interval</td> <td>0-10</td> <td>10-20</td> <td>20-30</td> <td>30-40</td> <td>40-50</td> <td>50-60</td> </tr> <tr> <td>Frequency</td> <td>5</td> <td>8</td> <td>20</td> <td>15</td> <td>7</td> <td>5</td> </tr> </table>	Class interval	0-10	10-20	20-30	30-40	40-50	50-60	Frequency	5	8	20	15	7	5			
Class interval	0-10	10-20	20-30	30-40	40-50	50-60												
Frequency	5	8	20	15	7	5												
4	A class teacher has the following absentee record of 40 students of a class for the whole term.																	
	<table border="1"> <tr> <td>No. of days</td> <td>0-6</td> <td>6-10</td> <td>10-14</td> <td>14-20</td> <td>20-28</td> <td>28-38</td> <td>38-40</td> </tr> <tr> <td>No. of students</td> <td>11</td> <td>10</td> <td>7</td> <td>4</td> <td>4</td> <td>3</td> <td>1</td> </tr> </table>	No. of days	0-6	6-10	10-14	14-20	20-28	28-38	38-40	No. of students	11	10	7	4	4	3	1	
No. of days	0-6	6-10	10-14	14-20	20-28	28-38	38-40											
No. of students	11	10	7	4	4	3	1											
	Write the above distribution as less than type cumulative frequency distribution.																	
	Answer :																	
	<table border="1"> <tr> <td>No. of days</td> <td>Less Than 6</td> <td>Less Than 10</td> <td>Less Than 14</td> <td>Less Than 20</td> <td>Less Than 28</td> <td>Less Than 38</td> <td>Less Than 40</td> </tr> <tr> <td>No. of students</td> <td>11</td> <td>21</td> <td>28</td> <td>32</td> <td>36</td> <td>39</td> <td>40</td> </tr> </table>	No. of days	Less Than 6	Less Than 10	Less Than 14	Less Than 20	Less Than 28	Less Than 38	Less Than 40	No. of students	11	21	28	32	36	39	40	
No. of days	Less Than 6	Less Than 10	Less Than 14	Less Than 20	Less Than 28	Less Than 38	Less Than 40											
No. of students	11	21	28	32	36	39	40											

LEVEL – 3

S/no	Question	Ans																		
1	<p>If the mean distribution is 25</p> <table border="1"> <tr> <td>Class</td> <td>0-10</td> <td>10-20</td> <td>20-30</td> <td>30-40</td> <td>40-50</td> </tr> <tr> <td>Frequency</td> <td>5</td> <td>18</td> <td>15</td> <td>P</td> <td>6</td> </tr> </table> <p>Then find p.</p>	Class	0-10	10-20	20-30	30-40	40-50	Frequency	5	18	15	P	6	P=16						
Class	0-10	10-20	20-30	30-40	40-50															
Frequency	5	18	15	P	6															
2	<p>Find the mean of the following frequency distribution using step deviation method</p> <table border="1"> <tr> <td>Class</td> <td>0-10</td> <td>10-20</td> <td>20-30</td> <td>30-40</td> <td>40-50</td> </tr> <tr> <td>Frequency</td> <td>7</td> <td>12</td> <td>13</td> <td>10</td> <td>8</td> </tr> </table>	Class	0-10	10-20	20-30	30-40	40-50	Frequency	7	12	13	10	8	25						
Class	0-10	10-20	20-30	30-40	40-50															
Frequency	7	12	13	10	8															
3	<p>Find the value of p if the median of the following frequency distribution is 50</p> <table border="1"> <tr> <td>Class</td> <td>20-30</td> <td>30-40</td> <td>40-50</td> <td>50-60</td> <td>60-70</td> <td>70-80</td> <td>80-90</td> </tr> <tr> <td>Frequency</td> <td>25</td> <td>15</td> <td>P</td> <td>6</td> <td>24</td> <td>12</td> <td>8</td> </tr> </table>	Class	20-30	30-40	40-50	50-60	60-70	70-80	80-90	Frequency	25	15	P	6	24	12	8	P=10		
Class	20-30	30-40	40-50	50-60	60-70	70-80	80-90													
Frequency	25	15	P	6	24	12	8													
4	<p>Find the median of the following data</p> <table border="1"> <tr> <td>Marks</td> <td>Less Than 10</td> <td>Less Than 30</td> <td>Less Than 50</td> <td>Less Than 70</td> <td>Less Than 90</td> <td>Less Than 110</td> <td>Less Than 130</td> <td>Less than 150</td> </tr> <tr> <td>Frequency</td> <td>0</td> <td>10</td> <td>25</td> <td>43</td> <td>65</td> <td>87</td> <td>96</td> <td>100</td> </tr> </table>	Marks	Less Than 10	Less Than 30	Less Than 50	Less Than 70	Less Than 90	Less Than 110	Less Than 130	Less than 150	Frequency	0	10	25	43	65	87	96	100	76.36
Marks	Less Than 10	Less Than 30	Less Than 50	Less Than 70	Less Than 90	Less Than 110	Less Than 130	Less than 150												
Frequency	0	10	25	43	65	87	96	100												

LEVEL – 4

S/no	Question	Ans																
1	<p>The mean of the following frequency distribution is 57.6 and the sum of the observations is 50. Find the missing frequencies f_1 and f_2.</p> <table border="1"> <tr> <td>Class</td> <td>0-20</td> <td>20-40</td> <td>40-60</td> <td>60-80</td> <td>80-100</td> <td>100-120</td> <td>Total</td> </tr> <tr> <td>Frequency</td> <td>7</td> <td>f_1</td> <td>12</td> <td>f_2</td> <td>8</td> <td>5</td> <td>50</td> </tr> </table>	Class	0-20	20-40	40-60	60-80	80-100	100-120	Total	Frequency	7	f_1	12	f_2	8	5	50	$f_1 = 8$ and $f_2 = 10$
Class	0-20	20-40	40-60	60-80	80-100	100-120	Total											
Frequency	7	f_1	12	f_2	8	5	50											
2	<p>The following distribution give the daily income of 65 workers of a factory</p> <table border="1"> <tr> <td>Daily income (in Rs)</td> <td>100-120</td> <td>120-140</td> <td>140-160</td> <td>160-180</td> <td>180-200</td> </tr> <tr> <td>No. of workers</td> <td>14</td> <td>16</td> <td>10</td> <td>16</td> <td>9</td> </tr> </table> <p>Convert the above to a more than type cumulative frequency distribution and draw its ogive.</p>	Daily income (in Rs)	100-120	120-140	140-160	160-180	180-200	No. of workers	14	16	10	16	9					
Daily income (in Rs)	100-120	120-140	140-160	160-180	180-200													
No. of workers	14	16	10	16	9													
3	<p>Draw a less than type and more than type ogives for the following distribution on the same graph. Also find the median from the graph.</p> <table border="1"> <tr> <td>Marks</td> <td>30-39</td> <td>40-49</td> <td>50-59</td> <td>60-69</td> <td>70-79</td> <td>80-89</td> <td>90-99</td> </tr> <tr> <td>No. of students</td> <td>14</td> <td>6</td> <td>10</td> <td>20</td> <td>30</td> <td>8</td> <td>12</td> </tr> </table>	Marks	30-39	40-49	50-59	60-69	70-79	80-89	90-99	No. of students	14	6	10	20	30	8	12	
Marks	30-39	40-49	50-59	60-69	70-79	80-89	90-99											
No. of students	14	6	10	20	30	8	12											

years	10	20	30	40	50	60	70	80
No. of persons	200	500	900	1200	1400	1500	1550	1560

9. If the median of the following data is 32.5. Find the value of x and y.

Class Interval	0-10	10-20	20-30	30-40	40-50	50-60	60-70	Total
frequency	x	5	9	12	y	3	2	40

SAMPLE PAPER FOR SA-1
CLASS – X
MATHEMATICS

Time : 3 hours

Maximum Marks : 90

General Instructions:

1. All questions are compulsory.
2. The question paper consists of 34 questions divided into four sections A, B, C and D. Section A comprises of 8 questions of 1 mark each, Section B comprises of 6 questions of 2 marks each. Section C comprises of 10 questions of 3 marks each and Section D comprises of 10 questions of 4 marks each.
3. Question numbers 1 to 8 in Section A are multiple choice questions where you are to select on correct option out of the given four.
4. There is no overall choice. However, internal choice has been provided in 1 question of two marks, 3 questions of three marks each and 2 questions of four marks each. You have to attempt only one of the alternatives in all such questions.
5. Use of calculator is not permitted.
6. An additional 15 minutes time has been allotted to read this question paper only.

SECTION A

[1] If the system of liner equations $x - ky = 2$ and $3x + 2y = -5$ has a unique solution, then the value of k is:-

- [a] $k = \frac{2}{3}$ [b] $k \neq -\frac{2}{3}$ [c] $k = \frac{3}{2}$ [d] $k \neq -\frac{3}{2}$

[2] If $\tan \theta = \frac{3}{4}$ then the value of $\frac{1 - \cos \theta}{1 + \cos \theta}$ is :-

- [a] $-\frac{1}{9}$ [b] $\frac{2}{9}$ [c] 1 [d] $\frac{1}{9}$

[3] If $\sin 3x = \cos [x - 26^\circ]$ and $3x$ is an actual angle, then the value of x is :-

- [a] 29° [b] 26° [c] 29° [d] 13°

[4] If $x = 2^3 \times 3 \times 5^2$, $y = 2^2 \times 3^3$, then HCF [x, y] is :-

- [a] 12 [b] 108 [c] 6 [d] 36

[5] If a positive integer p is divided by 3, then the remainder can be:-

- [a] 1 or 3 [b] 1, 2 or 3 [c] 0, 1 or 2 [d] 2 or 3

[6] If the given figure, the value of $\tan P - \cot R$ is:-

- [a] 1 [b] 0 [c] -1 [d] 2

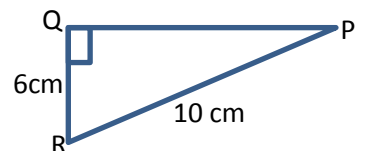

[7] Construction of a cumulative frequency table is useful in determining the :-

- [a] Mean [b] Median [c] Mode [d] All the above

[8] In the given figure, if $\angle A = \angle D = 90^\circ$, $AD = 6\text{cm}$, $CD = 8\text{cm}$ and $BC = 26\text{cm}$ then $\text{ar}(\Delta ABC)$ is :-

- [a] 240cm^2 [b] 48cm^2 [c] 120^2 [d] 260cm^2

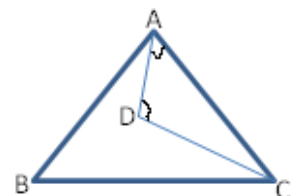

SECTION – B

[9] Find the value of p and q in the given figure, if ABCD is a rectangle

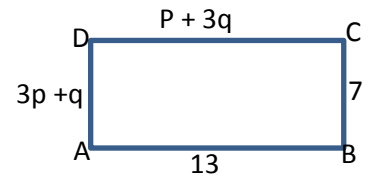

[10] If α and $\frac{1}{\alpha}$ are the zeroes of the polynomial $p(x) = 4x^2 - 2x + k - 4$, then find the value of k

Or

Divide the polynomial $p(x) = 5 - 3x + 3x^2 - x^3$ by $g(x) = x^2 - x + 1$ and find the quotient and remainder

[11] Without actually performing the long division, state whether $\frac{39}{343}$ will have a terminating or non-terminating, repeating decimal expansion

[12] Find the value of k, if $\frac{\cos 35^\circ}{\sin 55^\circ} + \frac{2 \sin \theta}{\cos(90^\circ - \theta)} = \frac{k}{2}$

[13] ABC is right angle triangle with $\angle ABC = 90^\circ$, $BD \perp AC$, $DM \perp BC$, and $DN \perp AB$. prove that $DM^2 = DN \times BC$.

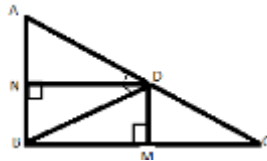

[14] The following table gives production yield per hectare of wheat of 100 farms of village:-

Production (in kg/hect)	25-35	35-45	45-55	55-65	65-75	75-85
No. of farms	4	6	10	26	35	19

Write the above distribution to a more than type distribution.

SECTION - C

[15] Prove that $\frac{7\sqrt{7}}{4}$ is irrational.

Or

Prove that $(16 - 5\sqrt{7})$ is irrational.

[16] If one diagonal of a trapezium divides the other diagonal in the ratio 1:2. Prove that one of the parallel sides is double the other?

[17] Prove that: $\frac{\sin \theta}{\cot \theta + \operatorname{cosec} \theta} = 2 + \frac{\sin \theta}{\cot \theta - \operatorname{cosec} \theta}$?

[18] The sum of the numerator and denominator, of a fraction is 8. If 3 is added to both the numerator and the denominator, the fraction become $\frac{3}{4}$. Find the fraction.

Or

Seven times a two digit number is equal to 4 times the number obtained by reversing the order of its digits. If the difference of digit is 3, find the number.

[19] If one zero of the polynomial $p(x) = 3x^2 - 8x + 2k + 1$ is seven times of other, then find the zeroes and the value of k.

[20] If $\sin \theta + \sin^2 \theta + \sin^3 \theta = 1$, prove that $\cos^6 \theta - 4\cos^4 \theta + 8\cos^2 \theta = 4$.

[21] Find the mean of the following data, using step-deviation method:-

Class Interval	0-20	20-40	40-60	60-80	80-100	100-120
Frequency	7	8	12	10	8	5

Or

Class Interval	0-20	20-40	40-60	60-80	80-100
Frequency	17	28	32	p	19

If the mean of the above data is 50, then find the value of p?

[22] Prove that $\tan\theta - \cot\theta = \frac{2 \sin^2\theta - 1}{\sin\theta \cos\theta}$

[23] In ΔABC , if AD is the median, then show that $AB^2 + AC^2 = 2[AD^2 + BD^2]$.

[24] Find the median of the following data:

Class-interval	10-20	20-30	30-40	40-50	50-60	60-70	70-80
Frequency	12	30	34	65	46	25	18

SECTION-D

[25] Prove that, if a line is drawn parallel to one side of a triangle, to intersect the other two sides in distinct points the other two sides are divided into the same ratio.

Or

Prove that in a right triangle the square of the hypotenuse is equal to the sum of the square of the other two sides?

[26] If $x = a \sin\theta$, $y = b \tan\theta$. prove that $\frac{a^2}{x^2} - \frac{b^2}{y^2} = 1$.

[27] On dividing $3x^3 + 4x^2 + 5x - 13$ by a polynomial $g(x)$, the quotient and remainder are $3x + 10$ and $16x + 43$ respectively, Find the polynomial $g(x)$.

[28] The fraction become $\frac{9}{11}$, if 2 is added to both the numerator and the denominator. If 3 is added to both the numerator and the denominator, it becomes $\frac{5}{6}$. Find the fraction.

[29] The following table shows the ages of the patients admitted in a hospital during a year:

AGE(in years)	5-15	15-25	25-35	35-45	45-55	55-65
No. of patients	6	11	21	23	14	5

Find the mode and mean of the data given above.

[30] The perpendicular from A on the side BC of the ΔABC intersects BC at D such that $DB = 3CD$ Prove that $2AB^2 = 2AC^2 + BC^2$.

[31] Draw the graph of following eqⁿ:-

$2x + 3y = 12$ and $x - y = 1$

Shade the region between the two lines and x – axis. Also, determine the vertices of the triangle so formed.

[32] Prove that: $\frac{\cos\theta}{1-\tan\theta} + \frac{\sin^2\theta}{\sin\theta-\cos\theta} = \sin\theta + \cos\theta$

Or

Evaluate: $\frac{\sin^2\theta + \sin^2(90^\circ - \theta)}{3(\sec^2 61^\circ - \cot^2 29^\circ)} - \frac{3 \cot^2 30^\circ \sin^2 54^\circ \sec^2 36^\circ}{2(\operatorname{cosec}^2 65^\circ - \tan^2 25^\circ)}$.

[33] In a sports meet, the number of players in Football, Hockey and Athletics are 48,60,132, respectively. Find the minimum number of room required, if in each room the same number of player are to be seated and all of them being in the same sports ?

[34] The following distribution gives the daily income of 65 workers of a factory :-

Daily income (in Rs)	100-120	120 – 140	140 -160	160- 180	180- 200
No. of worker	14	16	10	16	9

Convert the distribution above to a more than type cumulative frequency distribution and draw its ogive.

MARKING SCHEME

SUMMATIVE ASSESSMENT – 1

Sl.no		marks
1.	(b)	1
2.	(d)	1
3.	(a)	1
4.	(a)	1
5.	(c)	1
6.	(b)	1
7.	(b)	1
8.	(c)	1

SECTION-B

9.	Since opposite sides of the rectangle are equal So. $P+3q=13,$ $3p+q=7$ Solving $p=1,$ $q=4$	1 1
----	----------------------------------------------------------------------------------------------------	--------

10.	Since α and $\frac{1}{\alpha}$ are the zeros of the polynomial $P(x)=4x^2-2x+k-4$ So, $\alpha \times \frac{1}{\alpha} = \frac{k-4}{4}$ $\Rightarrow 1 = \frac{k-4}{4}$ $\Rightarrow k=8$	1 1
-----	-------------------------------------------------------------------------------------------------------------------------------------------------------------------------------------------------------------	--------

or

$$\begin{array}{r}
 x^2-x+1-x^3+3x^2-3x+5(-x+2) \\
 \underline{-x^3+x^2-x} \\
 2x^2-2x+5 \\
 \underline{-2x^2-2x+2} \\
 3
 \end{array}$$

	So, quotient = $-x+2$, remainder = 3	1/2
11.	Here, $\frac{39}{343} = \frac{3 \times 13}{7 \times 7 \times 7}$ Since denominator contains prime factor 7 other than 2 or 5 So, $\frac{39}{343}$ will have a non-terminating repeating decimal expansion.	1/2 1/2 1

12.	we have , $\frac{\cos 35^\circ}{\sin 55^\circ} + \frac{2\sin\theta}{\cos(90^\circ-\theta)} = \frac{k}{2}$ $\frac{\cos 35^\circ}{\cos(90^\circ-35^\circ)} + \frac{2\sin\theta}{\sin\theta} = \frac{k}{2}$ $1 + 2 = \frac{k}{2}$ $K = 6$	1 1
-----	-------------------------------------------------------------------------------------------------------------------------------------------------------------------------------------------------------------------------------------------------	--------

13.	$\because DN \perp AB$ and $\angle B = 90^\circ, DM \perp BC$ So, $DN \parallel BC$ and $DM \parallel AB$ so, $DNBM$ is a \parallel gm. $\Rightarrow DN = BM$	1
-----	--------------------------------------------------------------------------------------------------------------------------------------------------------------------------	---

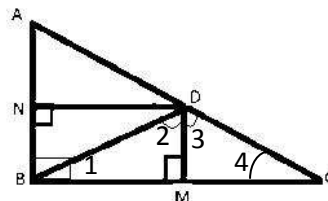

	In $\triangle BDM$ and $\triangle DCM,$ $\angle 1 = \angle 3, \angle 2 = \angle 4,$ by AA-Similarity $\triangle BDM \sim \triangle DCM$ $\Rightarrow \frac{DM}{CM} = \frac{BM}{DM}$ $\Rightarrow DM^2 = CM \times BM$ $\Rightarrow DM^2 = CM \times DN$ Proved.	1 1
--	--------------------------------------------------------------------------------------------------------------------------------------------------------------------------------------------------------------------------------------------------------------------------------	--------

14.		1 +1
-----	--	------

More than type	Commutative frequency
more than 25	100
more than 35	96
more than 45	90
more than 55	80
more than 65	54
more than 75	19

SECTION-C

15. Let us assume that, on contrary $\frac{7\sqrt{7}}{4}$ is rational
 $\therefore \frac{7\sqrt{7}}{4} = \frac{a}{b}$, where a, b are integers with $b \neq 0$ 1
 $\Rightarrow \sqrt{7} = \frac{4a}{7b}$ 1
 $\therefore \frac{4a}{7b}$ is a rational number. So, $\sqrt{7}$ is rational.
but this contradicts the fact that $\sqrt{7}$ is irrational.
so our assumption is wrong. 1
 $\therefore \sqrt{7}$ is irrational.

OR

- on contrary, Let $16-5\sqrt{7}$ is rational 1
so, $16-5\sqrt{7} = \frac{a}{b}$, where a, b are integers with $b \neq 0$
 $\Rightarrow \sqrt{7} = \frac{16b-a}{5b} = \frac{\text{integer}}{\text{integer}}$ 1
 $\Rightarrow \sqrt{7} = \text{rational}$ 1
But, this contradicts the fact that $\sqrt{7}$ is irrational.
so, $16-5\sqrt{7}$ is irrational. 1

16. 1

Given that
to prove
fig.

$$\frac{CP}{AP} = \frac{1}{2}$$

In Δ, ABP and ΔCDP ,

$$\angle ABP = \angle CDP \quad (\text{alt. } \angle\text{s})$$

$$\angle BAP = \angle DCP \quad (\text{alt. } \angle\text{s})$$

$$\therefore \Delta ABP \sim \Delta CDP \quad (\text{BY AA-Similarity})$$

$$\Rightarrow \frac{AB}{DC} = \frac{AP}{CP} = \frac{2}{1}$$

$$\Rightarrow AB = 2DC \quad \text{Proved.}$$

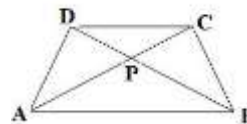

17. 1

Given: $\frac{\sin\theta}{\cot\theta + \operatorname{cosec}\theta} = 2 + \frac{\sin\theta}{\cot\theta - \operatorname{cosec}\theta}$ ½

$$\Rightarrow \frac{\sin\theta}{\cot\theta + \operatorname{cosec}\theta} - \frac{\sin\theta}{\cot\theta - \operatorname{cosec}\theta} = 2$$

L.H.S. = $\sin\theta \left[\frac{1}{\cot\theta + \operatorname{cosec}\theta} - \frac{1}{\cot\theta - \operatorname{cosec}\theta} \right]$ ½

$$= \sin\theta \left[\frac{-2\operatorname{cosec}\theta}{\cot^2\theta - \operatorname{cosec}^2\theta} \right] \quad 1$$

$$= \frac{-2\sin\theta \cdot \frac{1}{\sin\theta}}{-(\operatorname{cosec}^2\theta - \cot^2\theta)} = 2 \quad \text{Proved.} \quad 1$$

18. ½
Let the numerator be x and denominator be y , then fraction = $\frac{x}{y}$

As per question, 1

$$x + y = 8$$

$$x + 3 = 3$$

$$\frac{y + 3}{4} = \frac{3}{4}$$

solving, $x = 3, y = 5$ 1

$$\text{fraction} = \frac{x}{y} = \frac{3}{5} \quad ½$$

OR

Let the unit digit be x and tens digit be y ½
 then no. = $10y + x$

As per question 1

$$7(10y + x) = 4(10x + y)$$

and $x - y = 3$

solving $x = 6, y = 3$ 1

so No. = 36 ½

19. Let zeroes of the given polynomial $p(x)$ be α and β ½
 then, as per question

$$\beta = 7\alpha$$

sum of zeroes $\alpha + \beta = \frac{-b}{a}$ 1

$$\Rightarrow \alpha + 7\alpha = \frac{8}{3}$$

$$\Rightarrow \alpha = \frac{1}{3}$$

also, Product of zeroes $\alpha\beta = \frac{c}{a}$ ½

$$\Rightarrow 7\alpha \times \alpha = \frac{2k+1}{3}$$

solving, $k = \frac{2}{3}$ 1

zeroes are $\frac{1}{3}, \frac{7}{3}$

20. We have, ½

$$\sin\theta + \sin^2\theta + \sin^3\theta = 1$$

$$\sin\theta(1 + \sin^2\theta) = 1 - \sin^2\theta$$

$\Rightarrow \sin^2\theta(1 + \sin^2\theta) = \cos^2\theta$ squaring both sides ½

$\Rightarrow (1 - \cos^2\theta)(1 + 1 - \cos^2\theta)^2 = \cos^4\theta$ ½

solving, 1½

$$\cos^6\theta - 4\cos^4\theta + 8\cos^2\theta = 4$$

21. 1½

Class - Interval	Mid value (x_i)	frequency (f_i)	$u_i = \frac{x_i - d}{h}$	$f_i u_i$
0-20	10	7	-2	-14
20-40	30	8	-1	-8
40-60	A=50	12	0	0
60-80	70	10	1	10
80-100	90	8	2	16
100-120	110	5	3	15
		$\sum f_i = 50$		$\sum f_i u_i = 19$

Here, $A=50, h=20, \sum f_i = 50, \sum f_i u_i = 19$ ½

$$\text{Mean}(\bar{x}) = A + \left[\frac{\sum f_i u_i}{\sum f_i} \right] \times h$$

$$\text{Mean}(\bar{x}) = 50 + \frac{19}{50} \times 20 = 57.6$$
 1

OR

Class	frequency (f_i)	class - mark (x_i)	$f_i x_i$
0-20	17	10	170
20-40	28	30	840
40-60	32	50	1600
60-80	p	70	$70p$
80-100	19	90	1710
	$\sum f_i = 96 + p$		$\sum f_i x_i = 4320 + 70p$

$$\text{Mean}(\bar{x}) = \left[\frac{\sum f_i x_i}{\sum f_i} \right]$$
 ½

Given $\bar{x} = 50$

$$\Rightarrow 50 = \frac{4320+70p}{96+p} \quad 1$$

Solving $p = 24$

22. L.H.S. = $\tan\theta - \cot\theta$ ½

$$= \frac{\sin\theta}{\cos\theta} - \frac{\cos\theta}{\sin\theta}$$
 ½

$$= \frac{\sin^2\theta - \cos^2\theta}{\sin\theta\cos\theta}$$
 1

$$= \frac{\sin\theta\cos\theta}{\sin^2\theta - 1 + \sin^2\theta}$$
 1

$$= \frac{\sin\theta\cos\theta}{2\sin^2\theta - 1}$$
 1

$$= \frac{\sin\theta\cos\theta}{\sin\theta\cos\theta}$$
 ½

23. construction:-Draw $AE \perp BC$ ½

In $\triangle ADE$, $AD^2 = AE^2 + ED^2$ (Pythagoras theorem)
 $\Rightarrow AE^2 = AD^2 - DE^2$ (I)

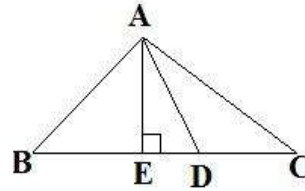

In $\triangle ABE$, $AB^2 = AE^2 + BE^2$ ($\angle B = 90^\circ$, Pythagoras theorem) 1
 $\Rightarrow AB^2 = AD^2 - DE^2 + (BD - DE)^2$ Using (I)
 $\Rightarrow AB^2 = AD^2 + BD^2 - 2BD \cdot DE$ -----(II)

In $\triangle ACE$, $AC^2 = AE^2 + EC^2$ 1
 $\Rightarrow AC^2 = AD^2 - DE^2 + (CD + DE)^2$
 $\Rightarrow AC^2 = AD^2 + CD^2 + 2CD \cdot DE$
 $\Rightarrow AC^2 = AD^2 + BD^2 + 2BD \cdot DE$ (As $BD = CD$) -----(III)

Adding (II) and (III) ½
 $AB^2 + AC^2 = 2[AD^2 + BD^2]$ Proved

24. 1

Class – Interval	Frequency (f_i)	Cumulative frequency
10-20	12	12
20-30	30	42
30-40	34	76
40-50	65	141
50-60	46	187
60-70	25	212
70-80	18	230
	$N = \sum f_i = 230$	

$$\frac{N}{2} = \frac{230}{2} = 115$$

Median class is 40-50 ½

$$l = 40, \quad cf = 76, \quad f = 65, \quad h = 10$$

$$\therefore \text{Median} = l + \frac{\frac{N}{2} - cf}{f} \times h$$
 ½

$$= 46$$
 1

25. correct given that, to prove, construction, fig. 2
 correct proof 2

OR

Correct fig., given that, to prove, construction 2
 correct proof 2

26. Given, $x = a \sin\theta$, $y = b \tan\theta$ 1

$$\Rightarrow \frac{a}{x} = \frac{1}{\sin\theta} \quad \text{and} \quad \frac{b}{y} = \frac{1}{\tan\theta}$$
 1

$$\Rightarrow \frac{a}{x} = \text{Cosec}\theta \quad \text{and} \quad \frac{b}{y} = \cot\theta$$
 1

$$\text{LHS} = \frac{a^2}{x^2} - \frac{b^2}{y^2} = \text{cosec}^2\theta - \cot^2\theta = 1 = \text{RHS} \quad \text{Proved.} \quad 1+1$$

27. Here, Dividend $p(x) = 3x^3 + 4x^2 + 5x - 13$ ½
 Quotient $q(x) = 3x + 10$
 Remainder $r(x) = 16x - 43$

By division algorithm ½

$$p(x) = g(x)q(x) + r(x)$$

$$g(x) = \frac{p(x) - r(x)}{q(x)} \quad 1$$

$$= \frac{(3x^3 + 4x^2 + 5x - 13) - (16x - 43)}{3x + 10}$$

$$= \frac{3x^3 + 4x^2 - 11x + 30}{3x + 10}$$

Correct division 2

$$\therefore g(x) = x^2 - 2x + 3$$

28. Let the fraction be $\frac{x}{y}$ ½

As per question

$$\frac{x+2}{y+2} = \frac{9}{11} \quad 1$$

$$\Rightarrow 11x - 9y + 4 = 0$$

$$\frac{x+3}{y+3} = \frac{5}{6} \quad 1$$

$$\Rightarrow 6x - 5y + 3 = 0$$

Solving above, $x = 7, y = 9$ 1

\therefore Fraction = $\frac{7}{9}$ ½

29. 1

Age (in years)	No. Of Patients (f_i)	Class Mark(x_i)	$f_i x_i$
5-15	6	10	60
15-25	11	20	220
25-35	21	30	630
35-45	23	40	920
45-55	14	50	700
55-65	5	60	300
	$\sum f_i = 80$		$\sum f_i x_i = 2830$

The modal class is 35-45 1/2

Here $l = 35, f_1 = 23, f_2 = 14, f_0 = 21, h = 10$

$$\text{Mode} = l + \left(\frac{f_1 - f_0}{2f_1 - f_0 - f_2} \right) * h \quad 1\frac{1}{2}$$

$$= 36.8$$

$$\text{Mean}(\bar{x}) = \frac{\sum f_i x_i}{\sum f_i} \quad 1$$

$$= 35.68$$

30. Given that, figure, to prove. ½

Proof:- ½

$$\because DB = 3 CD$$

$$\therefore DB = \frac{3}{4} BC$$

and $CD = \frac{1}{4} BC$

In right $\triangle ADB,$ 1

$$AB^2 = AD^2 + DB^2$$

In right $\triangle ACB,$

$$AC^2 = AD^2 + CD^2$$

$$\therefore AB^2 - AC^2 = DB^2 - CD^2 \quad 1$$

$$= \left(\frac{3}{4} BC \right)^2 - \left(\frac{1}{4} BC \right)^2 = \frac{8-1}{16} BC^2 = \frac{1}{2} BC^2$$

$$\Rightarrow AB^2 - AC^2 = \frac{1}{2} BC^2 \quad 1$$

$$\Rightarrow 2AB^2 = 2AC^2 + BC^2 \quad \text{Proved.}$$

31. Given Equations are 1
 $2x + 3y = 12$ ----- (i)
 $x - y = 1$ ----- (ii)
 from (i) $y = \frac{12-2x}{3}$
- | | | | |
|---|---|---|---|
| x | 0 | 3 | 6 |
| y | 4 | 2 | 0 |
- From (ii) $y = x - 1$ 2
- | | | | |
|---|----|---|---|
| x | 0 | 1 | 3 |
| y | -1 | 0 | 2 |
- Graph for above equations
- Vertices of triangle are (1,0), (6,0), (3,2) 1
32. LHS 1 1/2
- $$= \frac{\cos\theta}{1-\tan\theta} + \frac{\sin^2\theta}{\sin\theta-\cos\theta}$$
- $$= \frac{\cos^2\theta}{\cos^2\theta} + \frac{\sin^2\theta}{\sin\theta-\cos\theta}$$
- $$= \frac{\cos\theta-\sin\theta}{\cos^2\theta-\sin^2\theta} + \frac{\sin^2\theta}{\sin\theta-\cos\theta}$$
- $$= \frac{\cos\theta-\sin\theta}{(\cos\theta+\sin\theta)(\cos\theta-\sin\theta)}$$
- $$= \frac{\cos\theta-\sin\theta}{\cos\theta-\sin\theta}$$
- $$= \cos\theta + \sin\theta$$
- OR
- $$\frac{\sin^2\theta+\sin^2(90^\circ-\theta)}{3(\sec^2 61^\circ-\cot^2 29^\circ)} - \frac{3\cot^2 30^\circ \sin^2 54^\circ \sec^2 36^\circ}{2(\operatorname{cosec}^2 65^\circ-\tan^2 25^\circ)}$$
- $$= \frac{\sin^2\theta+\cos^2\theta}{3(\sec^2 61^\circ-\tan^2 61^\circ)} - \frac{3 \times (\sqrt{3})^2 \sin^2 54^\circ \operatorname{cosec}^2 54^\circ}{2(\operatorname{cosec}^2 65^\circ-\cot^2 65^\circ)}$$
- $$= \frac{1}{3} - \frac{3 \times 3 \times 1}{2} = \frac{1}{3} - \frac{9}{2} = -\frac{25}{6}$$
33. Prime factorization of $48=2^4 \times 3$ 1
 Prime factorization of $60=2^2 \times 3 \times 5$ 1
 Prime factorization of $132=2^2 \times 3 \times 11$ 1
- HCF of (48, 60, 132)= $2 \times 2 \times 3 = 12$ 1
 \therefore In each room 12 players of same sports can be accommodated. 1
- \therefore number of rooms required = $\frac{\text{Total number of players}}{\text{Number of players in a room}}$
- \Rightarrow number of rooms required = $\frac{48+60+132}{12}$ 1
 $= 20$
34. correct table 2
 correct graph 2

DETAILS OF THE CONCEPTS TO BE MASTERED BY EVERY CHILD OF CLASS X WITH EXERCISES AND EXAMPLES OF NCERT TEXT BOOK

SUMMATIVE ASSESSMENT -II

SYMBOLS USED

* : Important Questions, **: Very important questions, ***: Very, Very Important questions

01	Quadratic Equation	Standard form of quadratic equation	*	NCERT Text book Q.1.2, Ex 4.1
		Solution of quadratic equation by factorization	***	Example 3,4,5, Q.1, 5 Ex. 4.2
		Solution of quadratic equation by completing the square	**	Example 8,9 Q.1 Ex. 4.3
		Solution of quadratic equation by quadratic formula	***	Example. 10,11,13,14,15 , Q2,3(ii) Ex.4.3
		Nature of roots	***	Example 16 Q.1.2, Ex. 4.4
02	Arithmetic progression	General form of an A.P.	*	Exp-1,2, Ex. 5.1 Q.s2(a), 3(a),4(v)
		n th term of an A.P.	***	Exp. 3,7,8 Ex. 5.2 Q.4,7,11,16,17,18
		Sum of first n terms of an A.P.	** * ** ***	Exp.11,13,15 Ex. 5.3, Q.No.1(i, ii) Q3(i,iii) Q.7,10,12,11,6, Ex5.4, Q-1
03	Coordinate geometry	Distance formula	**	Exercise 7.1, Q.No 1,2,3,4,7,8
		Section formula Mid point formula	** ***	Example No. 6,7,9 Exercise 7.2, Q.No. 1,2,4,5 Example 10. Ex.7.2, 6,8,9. Q.No.7
		Area of Triangle	** ***	Ex.12,14 Ex 7.3 QNo-12,4 Ex.7.4, Qno-2
04	Some application of Trigonometry	Heights and distances		Example-2,3,4 Ex 9.1 Q 2,5,10,12,13,14,15,16
05	Circles	Tangents to a circle		Q3(Ex10.1) Q 1,Q6,Q7(Ex 10.2),4
		Number of tangents from a point to a circle	***	Theorem 10.1,10.2 Eg 2.1 Q8,9,,10,12,13 (Ex 10.2)
06	Constructions	Division of line segment in the given ratio	*	Const 11.1 Ex 11.1 Qno 1
		Construction of triangle similar to given triangle as per given scale	***	Ex 11.1 Qno-2,4,5,7
		Construction of tangents to a circle	***	Ex 11.2 Qno 1,4
07	Area related to circles	Circumference of a circle	*	Example 1 Exercise 12.1 Q.No 1,2,4
		Area of a circle	*	Example 5,3

		Length of an arc of a circle	*	Exercise 12.2 Q No 5
		Area of sector of a circle	**	Example 2 Exercise 12.2 QNo 1.2
		Area of segment of a circle	**	Exercise 12.2 Qno 4,7,9,3
		Combination of figures	***	Ex 12.3 Example 4.5 1,4,6,7,9,12,15
08	Surface area and volumes	Surface area of a combination of solids	**	Example 1,2,3 Exercise 13.1 Q1,3,6,7,8
		Volume of combination of a solid	**	Example 6 Exercise 13.2 Q 1,2,5,6
		Conversion of solids from one shape to another	***	Example 8 & 10 Exercise 13.3 Q 1,2,6,4,5
		Frustum of a cone	***	Example 12& 14 Exercise 13.4 Q 1,3,4,5 Ex-13.5, Q. 5
09	Probability	Events	*	Ex 15.1 Q4,8,9
		Probability lies between 0 and 1	**	Exp- 1,2,4,6,13
		Performing experiment	***	Ex 15 1,13,15,18,24

QUADRATIC EQUATIONS

KEY POINTS

1. The general form of a quadratic equation is $ax^2+bx+c=0$, $a \neq 0$. a , b and c are real numbers.
2. A real number x is said to be a root of the quadratic equation $ax^2+bx+c=0$ where $a \neq 0$ if $ax^2+bx+c=0$. The zeroes of the quadratic equation polynomial $ax^2+bx+c=0$ and the roots of the corresponding quadratic equation $ax^2+bx+c=0$ are the same.
3. Discriminant:- The expression b^2-4ac is called discriminant of the equation $ax^2+bx+c=0$ and is usually denoted by D . Thus discriminant $D= b^2-4ac$.
4. Every quadratic equation has two roots which may be real , co incident or imaginary.
5. IF α and β are the roots of the equation $ax^2+bx+c=0$ then

$$\alpha = \frac{-b+\sqrt{b^2-4ac}}{2a} \quad \text{And } \beta = \frac{-b-\sqrt{b^2-4ac}}{2a}$$

6. Sum of the roots , $\alpha + \beta = -\frac{b}{a}$ and product of the roots, $\alpha\beta = \frac{c}{a}$
7. Forming quadratic equation, when the roots α and β are given.
 $x^2-(\alpha + \beta)x + \alpha \cdot \beta = 0$
8. Nature of roots of $ax^2+bx+c=0$
 - i. If $D > 0$, then roots are real and unequal.
 - ii. $D = 0$, then the equation has equal and real roots.
 - iii. $D < 0$, then the equation has no real roots

LEVEL-I

1. IF $\frac{1}{2}$ is a root of the equation $x^2+kx-5/4=0$, then the value of K is
(a) 2 [Ans(d)]
(b) -2
(c) $\frac{1}{4}$
(d) $\frac{1}{2}$
2. IF $D > 0$, then roots of a quadratic equation $ax^2+bx+c=0$ are
(a) $\frac{-b+\sqrt{D}}{2a}$ (b) $\frac{-b+\sqrt{D}}{2a}$ (c) $\frac{-b-\sqrt{D}}{2a}$ (d) None of these [Ans(a)]
3. Discriminant of $x^2+5x+5=0$ is
(a) $5/2$ (b) -5 (c) 5 (d) -4 [Ans(c)]
4. The sum of roots of a quadratic equation $x^2+4x-320=0$ is
(a) -4 (b) 4 (c) $1/4$ (d) $1/2$ [Ans(a)]
5. The product of roots of a quadratic equation $2x^2+7x-4=0$ is
(a) $2/7$ (b) $-2/7$ (c) $-4/7$ (d) -2 [Ans(d)]
6. Values of K for which the equation $9x^2+2kx-1=0$ has real roots are:
(a) $k \geq \pm 3$ (b) $k \geq 3$ or $k \leq -3$ (c) $k \geq -3$ (d) $k \leq \pm 3$ [Ans(b)]

LEVEL-II

1. For what value of k , $x=a$ is a solution of equation $x^2-(a+b)x+k=0$?

Ans. $K=ab$

2. Represent the situation in the form of quadratic equation:-

Rohan 's mother is 26 years older than him . the product of their ages (in years) 3 years from now will be 360. We would like to find Rohan's present age.

Ans . $x^2+32x -273 = 0$ where x (in years) is Rohan's present age

3. Find the roots of $x^2 -3x-10 = 0$

Ans . -2 ,5

4. Find two consecutive positive integers , sum of whose squares is 365.

Ans .13,14

5. Find the roots of Quadratic equation $4x^2 +4\sqrt{3}x+3 = 0$ by using the quadratic formula.

Ans . $-\sqrt{\frac{3}{2}}, -\sqrt{\frac{3}{2}}$

6. Find the discriminant of the Quadratic equation $2x^2-4x+3 = 0$ and hence find the nature of its roots .

Ans . $D= -8<0$ its no real roots.

LEVEL - 3

1. If $x = 2$ and $x = 3$ are roots of the equation $3x^2 - 2kx + 2m = 0$ find the value of k and m .

Ans. $K = \frac{15}{2}, m = 9$

2. Solve the equation:

$$\frac{x}{x+1} + \frac{x+1}{x} = \frac{34}{15}, x \neq 0, x \neq -1$$

Ans. $x = \frac{3}{2}$ or $x = \frac{-5}{2}$

3. Solve the equation $2x^2 - 5x + 3 = 0$ by the method of completing square.

Ans. $x = \frac{3}{2}$ or $x = 1$

4. Using quadratic formula, solve the equation: $p^2x^2 + (p^2 - q^2)x - q^2 = 0$.

Ans. $x = -1$, or $x = \frac{q^2}{p^2}$

5. The sum of two numbers is 15, if the sum of their reciprocals is $\frac{3}{10}$, find the numbers.

Ans. 10 and 5

[LEVEL - 4]

1. In a class test , the sum of shefali's marks in maths and English is 30. Had she got 2 marks more in maths and 3 marks less in English, the product of their marks would have been 210. Find her marks in the two subjects.

Ans. Marks in maths = 12 , marks in English =18 or ,marks in maths = 13 , marks in English = 17

2. Two water taps together can fill a tank in $9\frac{3}{8}$ hours. The tap of larger diameter takes 10 hours less than the smaller one to fill the tank separately. Find the time in which each tap can separately fill the tank.

Ans . 15 hours , 25 hours.

3. Find the roots of equation $\frac{1}{x+4} - \frac{1}{x-7} = \frac{11}{13}$, $x \neq -4, 7$

Ans . 1 , 2

4. Solve the following equation for 'x' $9x^2 - 9(a+b)x + (2a^2+5ab+2b^2) = 0$

$$\text{Ans. } \frac{2a+b}{3}, \frac{a+2b}{3}$$

5. If the roots of the equation $(a-b)x^2 + (b-c)x + (c-a) = 0$ are equal, prove that $2a = b+c$.

Self Evaluation

1. Find the value of p so that the equation $3x^2 - 5x + 2p = 0$ has equal roots. Also find the roots.
2. The sum of two numbers is 15. If the sum of their reciprocals is $\frac{3}{10}$, *find the two numbers.*
3. Find a and b such that $x+1$ and $x+2$ are factors of the polynomials $x^3 + ax^2 - bx + 10$.
4. Find the quadratic equation whose roots are $2 + \sqrt{3}$ and $2 - \sqrt{3}$
5. A person on tour has Rs. 360 for his daily expenses. If he exceeds his tour programme by four days, he must cut down his daily expenses by Rs 3 per day. Find the number of days of his tour programme.
6. Divide 29 into two parts so that the sum of squares of the parts is 425.
7. Solve for x : $9x^2 - 6ax + (a^2 - b^2) = 0$
8. If the equation $(1 + m^2)x^2 + 2mcx + c^2 - a^2 = 0$ has equal roots, show that $c^2 = a^2(1 + m^2)$

ARITHMETIC PROGRESSION

(Key Points)

- Arithmetic progression (A.P.) :- An A.P. is a list of numbers in which each term is obtained by adding a fixed number to the preceding term except the first term.
- This fixed number is called the common difference of the A.P.
- If a is first term and d is common difference of an A.P. , then the A.P is $a, a+d, a+2d, a+3d, \dots$
- The n^{th} term of an a.p is denoted by a_n and $a_n = a+(n-1) d$, where a = first term and d = common difference.
- n^{th} term from the end = $l - (n-1) d$, where l = last term.
- Three terms $a-d, a, a+d$ are in A.P with common difference d .
- Four terms $a-3d, a-d, a+d, a+3d$ are in A.P with common diff. $2d$.
- The sum of first n natural number is $\frac{n(n+1)}{2}$
- The sum of n terms of an A.P with first term a and common difference d is denoted by $S_n = \frac{n}{2}\{ 2a+(n-1) d \}$ also , $S_n = \frac{n}{2}(a+l)$ where , l = last term.
- $a_n = S_n - S_{n-1}$. Where $a_n = n^{th}$ term of an A.P
- $D = a_n - a_{n-1}$. Where d = common difference of an A.P.

[LEVEL -1]

1. Find n^{th} term of $-15, -18, -21, \dots$

Ans .-3 (n+4)

2. Find the common diff. of A.P $1, -2, -5, -8, \dots$

Ans . -3

3. Find the A.P whose first term is 4 and common difference is -3

Ans . a.p = $4, 1, -2, -5, -8, \dots$

4. Find 5^{th} term from end of the AP : $17, 14, 11, \dots, -40$.

Ans . -28

5. If $2p, p+10, 3p+2$ are in AP then find p .

Ans . $p = 6$

6. If arithmetic mean between $3a$ and $2a-7$ is $a+4$, then find a .

Ans . $a = 5$

7. Find sum of all odd numbers between 0 & 50.

Ans . 625

8. If $a = 5, d = 3$ and $a_n = 50$, then find n .

Ans . $n = 16$

9. For what value of n are the n^{th} term of two AP , $63, 65, 67, \dots$ and $3, 10, 17, \dots$ equal?

Ans . $n = 13$.

10. If sum of n terms of an AP is $2n^2+5n$, then find its n^{th} term.

Ans. $4n+3$.

[LEVEL - 2]

1. Find n^{th} term of an AP is $7-4n$. find its common difference.

Ans. -4.

2. Which term of an AP $5, 2, -1, \dots$ will be -22 ?

Ans. 10^{th} term .

3. Write the next term of an AP $\sqrt{8}, \sqrt{18}, \sqrt{32}, \dots$

Ans. $5\sqrt{2}$.

4. Determine 27^{th} term of an AP whose 9^{th} term is -10 and common difference is $1\frac{1}{4}$

Ans. $927 = \frac{25}{2}$.

5. Find the sum of series $103+101+99+\dots+49$.

Ans. 2128.

6. Which term of the AP $3, 15, 27, 39, \dots$ will be 132 more than its 54^{th} term ?

Ans. 65^{th} term .

7. How many three digit numbers are divisible by 7 ?

Ans. 128.

8. Given $a = 2$, $d = 8$, $s_n = 90$, find n and a_n .

Ans. $n = 5$ & $a_n = 34$

(LEVEL- 3)

1. Which term of the sequence $-1, 3, 7, 11, \dots$ Is 95?

Ans. 25^{th} term

2. How many terms are there in the sequence $3, 6, 9, 12, \dots, 111$?

Ans. 37 terms

3. The first term of an AP is -7 and the common difference 5, find its 18^{th} term and the general term.

Ans. $a_{18} = 78n$ & $a_n = 5n - 12$

4. How many numbers of two digits are divisible by 3?

Ans. 30

5. If the n^{th} term of an AP is $(2n+1)$, find the sum of first n terms of the AP.

Ans. $S_n = n(n+2)$

6. Find the sum of all natural numbers between 250 and 1000 which are exactly divisible by 3.

Ans. 156375.

Problems for self evaluation.

1. Show that the sequence defined by $t_n = 4n + 7$ is an AP.

2. Find the number of terms for given AP : $7, 13, 19, 25, \dots, 205$.

3. The 7^{th} term of an AP is 32 and its 13^{th} term is 62. Find AP.

4. Find the sum of all two digit odd positive nos.

5. Find the value of 'x' for AP. $1+6+11+16+\dots+X=148$.

6. Find the 10^{th} term from the end of the AP $8, 10, 12, \dots, 126$.

7. The sum of three numbers of AP is 3 and their product is -35 . Find the numbers.

8. A man repays a loan of Rs3250 by paying Rs20 in the first month and then increase the payment by Rs15 every month .How long will it take him to clear the loan ?

9. The ratio of the sums of m and n terms of an AP is $m^2 : n^2$. Show that the ratio of the m th and n th terms is $(2m-1) : (2n-1)$.
10. In an AP, the sum of first n terms is $\frac{3n^2}{2} + \frac{5n}{2}$, Find its 25th term.

CO-ORDINATE GEOMETRY

IMPORTANT CONCEPTS

TAKE A LOOK

1. Distance Formula:-

The distance between two points A(x₁,y₁) and B (x₂,y₂) is given by the formula.

$$AB = \sqrt{(X_2 - X_1)^2 + (Y_2 - Y_1)^2}$$

COROLLARY:- The distance of the point P(x,y) from the origin O(0,0) is given by

$$OP = \sqrt{(X-0)^2 + (Y-0)^2} \quad \text{ie } OP = \sqrt{X^2 + Y^2}$$

2. Section Formula :-

The co-ordinates of the point P(x,y) which divides the line segment joining A(x₁,y₁) and B(x₂,y₂) internally in the ratio m:n are given by .

$$X = \frac{mx_2 + nx_1}{m+n}$$

$$Y = \frac{my_2 + ny_1}{m+n}$$

3. Midpoint Formula:-

If R is the mid-point, then m₁=m₂ and the coordinates of R are

$$R \left(\frac{x_1 + x_2}{2}, \frac{y_1 + y_2}{2} \right)$$

4. Co-ordinates of the centroid of triangle:-

The co-ordinates of the centroid of a triangle whose vertices are P(x₁,y₁), Q(x₂,y₂) and R(x₃,y₃) are

$$\left(\frac{x_1 + x_2 + x_3}{3}, \frac{y_1 + y_2 + y_3}{3} \right)$$

5. Area of a Triangle:-

The area of the triangle formed by the points P(x₁,y₁), Q(x₂,y₂) and R(x₃,y₃) is the numerical value of the expression.

$$\text{ar } (\Delta PQR) = \frac{1}{2} \left[x_1(y_2 - y_3) + x_2(y_3 - y_1) + x_3(y_1 - y_2) \right]$$

LEVEL- 1

1. If the coordinates of the points P and Q are (4,-3) and (-1,7). Then find the abscissa of a point R on the line segment PQ such that $\frac{PR}{PQ} = \frac{3}{5}$

Ans. 1

2. If P ($\frac{a}{3}$, 4) is the midpoint of the line segment joining the points Q (-6 , 5) and R (-2 , 3) , then find the value of a .

Ans . -12

3. A line intersects y -axis and x-axis at the points P and Q respectively . If (2 , -5) is the midpoint of PQ , then find the coordinates of P and Q respectively .

Ans. (0,-10) and (4,0)

4. If the distance between the points (4,p)&(1,0) is 5, then find the value of p

Ans. ± 4

5. If the point A(1,2), B(0,0) and C(a,b) are collinear, then find the relation between a and b.

6. Find the coordinate of the point on x-axis which is equidistant from (2,-5) and (-2,9). Ans. $2a=b$
7. Find the coordinates of a point A, where AB is diameter of a circle whose centre is (2, -3) and B is (1, 4) Ans. (-7,0)
8. Find the centroid of triangle whose vertices are (3, -7), (-8, 6) and (5, 10). Ans. (3, -10)
- Ans. (0, 3)

LEVEL-2

1. Point P (5, -3) is one of the two points of trisection of the line segment joining the points A (7, -2) and B (1, -5) near to A. Find the coordinates of the other point of trisection. Ans. (3, -4)
2. Show that the point P (-4, 2) lies on the line segment joining the points A (-4, 6) and B (-4, -6). Ans. 5 units
3. If A (-2, 4), B (0, 0), C (4, 2) are the vertices of a ΔABC , then find the length of median through the vertex A. Ans. 1, -11
4. Find the value of x for which the distance between the points P (4, -5) and Q (12, x) is 10 units. Ans. 2
5. If the points A (4,3) and B (x,5) are on the circle with centre O(2,3) then find the value of x. Ans. $\sqrt{2} c$
6. What is the distance between the point A (c, 0) and B (0, -c)? Ans. $p = -1$
7. For what value of p, are the points (-3, 9), (2, p) and (4, -5) collinear?

LEVEL-3

1. Show that the points (3, 2), (0, 5), (-3, 2) and (0, -1) are the vertices of a square.
2. Point P divides the line segment joining the points A(2,1) and B(5,-8) such that $AP:AB=1:3$. If P lies on the line $2x-y+k=0$, then find the value of k. Ans. k = -8
3. Points P, Q, R, and S in that order are dividing a line segment joining A (2, 6) and B (7, -4) in five equal parts. Find the coordinates of point P and R? Ans. P (3, 4), R (5, 0)
4. Find a relation between x and y if the points (2, 1), (x, y) and (7, 5) are collinear. Ans. $4x - 5y + 3 = 0$
5. If A (-4, -2), B (-3, -5), C (3, -2) and D (2, 3) are the vertices of a quadrilateral, then find the area of the quadrilateral. Ans. 28 sq. units
6. Find the values of x for which the distance between the points P(2, -3) and Q(x, 5) is 10 units Ans. $x = 8$ or $x = -4$
7. Find the point on y-axis which is equidistant from the points (5, -2) and (-3, 2) Ans. (0, -2)

LEVEL-4

1. A (6, 1), B (8, 2), C (9, 4) are the three vertices of a parallelogram ABCD. If E is the midpoint of DC, then find the area of ΔADE .

Ans. $\frac{3}{4}$ sq. unit

2. In each of following , find the value of 'k' for which the points are collinear .

(a) (7, -2) , (5, 1) , (3, k) (b) (8, 1) , (k, -4) ,(2,-5)

Ans. (a) $k = 4$ (b) $k = 3$

3. Find the area of the triangle formed by joining the mid points of the sides of the triangle whose vertices are (0, -1) , (2,1) and (0,3). Find the ratio of this area to the area of the given triangle.

Ans. 1:4

4. Find the coordinates of the points which divides the line segment joining the points (-2,0) and (0,8) in four equal parts.

Ans. $(-\frac{3}{2}, 2)$, $(-1,4)$, $(-\frac{1}{2}, 6)$

5. Find the area of the quadrilateral whose vertices taken in order are (-4, -2), (-3, -5), (3, -2) and (2,3)

Ans. 28 sq. units

6. Find the area of the rhombus, if its vertices are (3,0), (4,5), (-1,4) and (-2,-1) taken in order.

Ans. 24 sq. units

HOTS /SELF EVALUATION

1. Two opposite vertices of a square are (-1,2) and (3, 2). Find the coordinates of the other two vertices.

[Ans. (1,0) and (1,4)]

2. Find the centre of a circle passing through the points (6,-6), (3, 7) and (3, 3). [Ans.3,-2]

3. If the distance between the points (3,0) and (0,y) is 5 units and y is positive, then what is the value of y? [Ans.4]

4. If the points (x,y) ,(-5,-2) and (3,-5) are collinear, then prove that $3x+8y+31 = 0$.

5. Find the ratio in which the Y-axis divides the line segment joining the points (5, -6) and (-1, -4). Also find the coordinates of the point of division.

Ans. 5:1; (0,-13/3)

6. Find k so that the point P(-4,6) lies on the line segment joining A (k,0) and B (3, -8). Also find the ratio in which P divides AB.

[Ans. 3:7 externally; k=-1]

7. By distance formula, show that the points (1, -1), (5,2) and (9,5) are collinear.

**APPLICATIONS OF TRIGONOMETRY
(HEIGHT AND DISTANCES)**

KEY POINTS

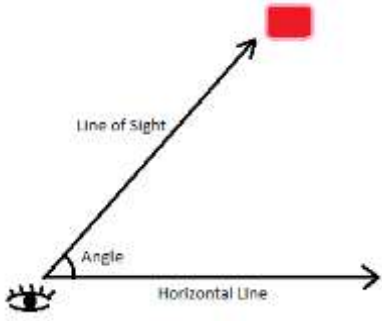
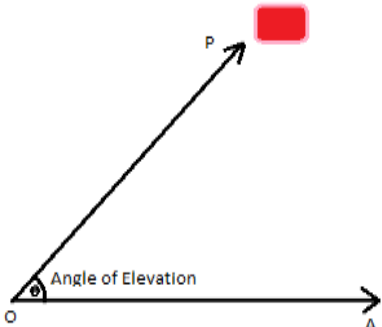
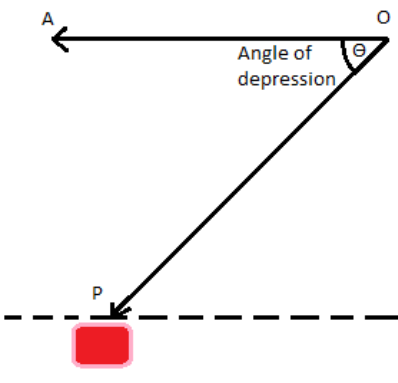
<p>Line of sight Line segment joining the object to the eye of the observer is called the line of sight.</p>	
<p>Angle of elevation When an observer sees an object situated in upward direction, the angle formed by line of sight with horizontal line is called angle of elevation.</p>	
<p>Angle of depression When an observer sees an object situated in downward direction the angle formed by line of sight with horizontal line is called angle of depression.</p>	

LEVEL- 1

1. A pole 6m high casts a shadow $2\sqrt{3}$ m long on the ground, then find the sun's elevation?
Ans. 60°
2. If $\sqrt{3}\tan\theta = 1$, then find the value of $\sin^2\theta - \cos^2\theta$
Ans. $-1/2$
3. An observer 1.5m tall is 20.5 metres away from a tower 22m high. Determine the angle of elevation of the top of the tower from the eye of the observer.
Ans. 45°
4. A ladder 15m long just reaches the top of vertical wall. If the ladder makes an angle 60° with the wall, find the height of the wall
Ans. $15/2$ m
5. In a rectangle ABCD, $AB = 20\text{cm}$ $\angle BAC = 60^\circ$ then find the length of the side AD.
Ans. $20\sqrt{3}\text{cm}$
6. Find the angle of elevation of the sun's altitude when the height of the shadow of a vertical pole is equal to its height:
Ans. 45°

7. From a point 20m away from the foot of a tower, the angle of elevation of top of the tower is 30° , find the height of the tower.

Ans. $\frac{20}{\sqrt{3}}m$

8. In the adjacent figure, what are the angles of depression of the top and bottom of a pole from the top of a tower h m high:

Ans $45^\circ, 60^\circ$

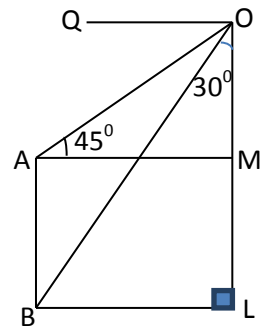

LEVEL - 2

1. In ΔABC , $\angle B = 45^\circ$, $\angle C = 45^\circ$, $AB = 5cm$ then find the length of the other two sides.

Ans. $5cm, 5\sqrt{2}cm$

2. From a point 20 m away from the foot of the tower, the angle of elevation of the top of the tower is 30° , find the height of the tower.

Ans. $\frac{20\sqrt{3}}{3}m$

3. A ladder 50m long just reaches the top of a vertical wall. If the ladder makes an angle of 60° with the wall, find the height of the wall.

Ans. 25 m

4. A circus artist is climbing a 20m long rope, which is tightly stretched and tied from the top of a vertical pole to the ground. Find the height of the pole, if the angle made by the rope with the ground level is 30° .

Ans. 10 m

5. A tree breaks due to storm and the broken part bends so that the top of the tree touches the ground making an angle 30° with it. The distance between the foot of the tree to the point where the top touches the ground is 8m. Find the height of the tree.

Ans. $8\sqrt{3}m$

LEVEL - 3

1. The shadow of a tower standing on a level plane is found to be 50m longer when sun's elevation is 30° then when it is 60° . Find the height of the tower.

Ans. $25\sqrt{3}m$

2. The angle of depression of the top and bottom of a tower as seen from the top of a 100m high cliff are 30° and 60° respectively. Find the height of the tower. [Ans.66.67m]

3. From a window (9m above ground) of a house in a street, the angles of elevation and depression of the top and foot of another house on the opposite side of the street are 30° and 60° respectively. Find the height of the opposite house and width of the street.

[Ans.12m,3√3m]

4. From the top of a hill, the angle of depression of two consecutive kilometer stones due east are found to be 30° and 45° . Find the height of the hill.

Ans.1.37 km

5. Two poles of equal heights are standing opposite each other on either side of the road, which is 80m wide. From a point between them on the road the angles of elevation of the top of the poles are 60° and 30° . Find the heights of pole and the distance of the point from the poles.

[Ans; h=34.64m; 20m, 60m].

6. The angle of elevation of a jet fighter from a point A on the ground is 60° . After a flight of 15 seconds, The angle of elevation changes to 30° . If the jet is flying at a speed of 720km/hr, find the constant height at which the jet is flying.

[Ans;1500m]

7. A window in a building is at a height of 10m above the ground. The angle of depression of a point P on the ground from the window is 30° . The angle of elevation of the top of the building from the point P is 60° . Find the height of the building.

[Ans; 30m]

8. A boy, whose eye level is 1.3m from the ground, spots a ballon moving with the wind in a horizontal line at same height from the ground. The angle of elevation of the ballon from the eyes of the boy at any instant is 60° . After 2 seconds, the angle of elevation reduces to 30° . If the speed of the wind at that moment is $29\sqrt{3}$ m/s, then find the height of the ballon from the ground.

[Ans; 88.3m]

9. A man on the deck on a ship 14m above water level, observes that the angle of elevation of the top of a cliff is 60° and the angle of depression of the base of the cliff is 30° . Calculate the distance of the cliff from the ship and the height of the cliff.

[Ans ; h= 56m, distance 24.25m]

10. A straight highway leads to the foot of a tower. A man standing at the top of the tower observes a car at an angle of depression of 30° , which is approaching the foot of tower with a uniform speed. Six minutes later, the angle of depression of the car is found to be 60° . Find the time taken by the car to reach the foot of the tower.

[Ans.3 minutes]

SELF EVALUATION/HOTS

1. An aeroplane when flying at a height of 3125m from the ground passes vertically below another

plane at an instant when the angle of elevation of the two planes from the same point on the ground are 30° and 60° respectively. Find the distance between the two planes at that instant.

[Ans ; 6250m]

2. From the top of a building 60m high, the angles of depression of the top and bottom of a vertical lamp post are observed to be 30° and 60° respectively. Find [i] horizontal distance between the building and the lamp post [ii] height of the lamp post.

[Ans. 34.64m h=40m]

3. A vertical tower stands on a horizontal plane and is surmounted by a vertical flag staff of height h m. At a point on the plane, the angles of elevation of the bottom and the top of the flag staff are α and β , respectively. Prove that the height of the tower is $\frac{h \tan \alpha}{\tan \beta - \tan \alpha}$
4. The angle of elevation of a cloud from a point 60m above a lake is 30° and the angle of depression of the reflection of the cloud in the lake is 60° . Find the height of the cloud from the surface of the lake.

[Ans 120m]

Circle

KEY POINTS

Tangent to a circle :

A tangent to a circle is a line that intersect the circle at only one point.

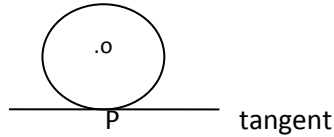

P= point of contact

- There is only one tangent at a point on a circle.
- There are exactly two tangents to a circle through a point lying outside the circle.
- The tangent at any point of a circle is perpendicular to the radius through the point of contact.
- The length of tangents drawn from an external point to a circle are equal.

(1 Mark Questions)

1. If radii of the two concentric circles are 15cm and 17cm , then find the length of each chord of one circle which is tangent to one other.

Ans. 16cm

2. If two tangents making an angle of 120° with each other , are drawn to a circle of radius 6cm, then find the angle between the two radii, which are drawn to the tangents.

3. In the adjoining figure , ΔABC is circumscribing a circle , then find the length of BC.

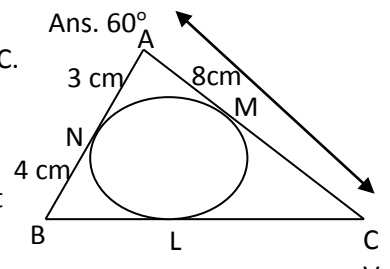

Ans. 9cm

4. PQ is a chord of a circle and R is point on the minor arc. If PT is a tangent at point P such that $\angle QPT = 60^\circ$ then find $\angle PRQ$.

Ans. 120°

5. If a tangent PQ at a point P of a circle of radius 5cm meets a line through the centre O at a point Q such that $OQ = 12$ cm then find the length of PQ.

Ans. $\sqrt{119}$ cm

6. From a point P, two tangents PA and PB are drawn to a circle $C(O,r)$. If $OP = 2r$,then what is the type of ΔAPB .

Ans. Equilateral triangle

7. If the angle between two radii of a circle is 130° , then find the angle between the tangents at the end of the radii.

Ans. 50° .

8. ABCD is a quadrilateral. A circle centred at O is inscribed in the quadrilateral. If $AB = 7$ cm , $BC = 4$ cm , $CD = 5$ cm then find DA.

Ans. 8 cm

9. In a ΔABC , $AB = 8$ cm , $\angle ABC = 90^\circ$. Then find the radius of the circle inscribed in the triangle.

Ans. 2cm

(Two Marks Questions)

- Two tangents PA and PB are drawn from an external point P to a circle with centre O. Prove that OAPB is a cyclic quadrilateral.
- If PA and PB are two tangents drawn to a circle with centre O, from an external point P such that PA=5cm and $\angle APB = 60^\circ$, then find the length of the chord AB.

Ans. 5cm

- CP and CQ are tangents from an external point C to a circle with centre O. AB is another tangent which touches the circle at R and intersects PC and QC at A and B respectively. If CP = 11cm and BR = 4cm, then find the length of BC.

Ans. 7cm

- If all the sides of a parallelogram touch a circle, show that the parallelogram is a rhombus.
- Prove that the perpendicular at the point of contact to the tangent to a circle passes through the centre of the circle.
- In adjacent figure; AB & CD are common tangents to two circles of unequal radii. Prove that AB=CD.

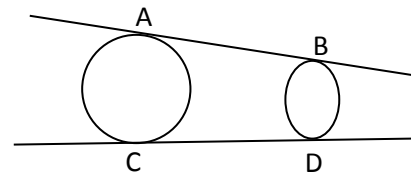

(Three Marks Questions)

- If quadrilateral ABCD is drawn to circumscribe a circle then prove that $AB+CD=AD+BC$.
- Prove that the angle between the two tangents to a circle drawn from an external point, is supplementary to the angle subtended by the line segment joining the points of contact to the centre.
- AB is a chord of length 9.6cm of a circle with centre O and radius 6cm. If the tangents at A and B intersect at point P then find the length PA.

Ans. 8cm

- The incircle of a ΔABC touches the sides BC, CA & AB at D, E and F respectively. If $AB=AC$, prove that $BD=CD$.
- Prove that the intercept of a tangent between two parallel tangents to a circle subtends a right angle at the centre of the circle.
- PQ and PR are two tangents drawn to a circle with centre O from an external point P. Prove that $\angle QPR=2\angle OQR$.

(Four Marks Questions)

1. Prove that the length of tangents drawn from an external point to a circle are equal. Hence, find BC, if a circle is inscribed in a ΔABC touching AB, BC & CA at P, Q & R respectively, having $AB=10\text{cm}$, $AR=7\text{cm}$ & $RC=5\text{cm}$.

Ans. 8cm

2. Prove that the tangent at any point of a circle is perpendicular to the radius through the point of contact. Using the above, do the following: If O is the centre of two concentric circles, AB is a chord of the larger circle touching the smaller circle at C, then prove that $AC=BC$.

3. A circle touches the side BC of a ΔABC at a point P and touches AB and AC when produced, at Q & R respectively. Show that $AQ=1/2$ (perimeter of ΔABC).

4. From an external point P, a tangent PT and a line segment PAB is drawn to circle with centre O, ON is perpendicular to the chord AB. Prove that $PA.PB=PN^2-AN^2$.

5. If AB is a chord of a circle with centre O, AOC is diameter and AT is the tangent at the point A, then prove that $\angle BAT=\angle ACB$.

6. The tangent at a point C of a circle and diameter AB when extended intersect at P. If $\angle PCA=110^\circ$, find $\angle CBA$.

Ans. 70°

[Self Evaluation/HOTS Questions]

1. If PA and PB are tangents from an external point P to the circle with centre O, the find $\angle AOP+\angle OPA$.

Ans. 90°

2. ABC is an isosceles triangle with $AB=AC$, circumscribed about a circle . Prove that the base is bisected by the point of contact.

3. AB is diameter of a circle with centre O. If PA is tangent from an external point P to the circle with $\angle POB=115^\circ$ then find $\angle OPA$.

Ans. 25°

4. PQ and PR are tangents from an external point P to a circle with centre . If $\angle RPQ=120^\circ$, Prove that $OP=2PQ$.

5. If the common tangents AB and CD to two circles $C(O,r)$ and $C'(O',r')$ intersect at E, then prove that $AB=CD$.

6. If a, b, c are the sides of a right triangle where c is the hypotenuse , then prove that radius r of the circle touches the sides of the triangle is given by $r=(a+b-c)/2$.

CONSTRUCTION

KEY POINTS

1. Division of line segment in the given ratio.
2. Construction of triangles:-
 - a. When three sides are given.
 - b. When two sides and included angle given.
 - c. When two angles and one side given.
 - d. Construction of right angled triangle.
3. Construction of triangle similar to given similar to given triangle as per given scale.
4. Construction of triangles to a circle.

LEVEL - I

1. Divide a line segment in given ratio.
2. Draw a line segment $AB=8\text{cm}$ and divide it in the ratio 4:3.
3. Divide a line segment of 7cm internally in the ratio 2:3.
4. Draw a circle of radius 4 cm. Take a point P on it. Draw tangent to the given circle at P.
5. Construct an isosceles triangle whose base 7.5 cm and altitude is 4.2 cm.

LEVEL –II

1. Construct a triangle of sides 4cm , 5cm and 6cm and then triangle similar to it whose side are $\frac{2}{3}$ of corresponding sides of the first triangle.
2. Construct a triangle similar to a given ΔABC such that each of its sides is $\frac{2}{3}$ rd of the corresponding sides of ΔABC . It is given that $AB=4\text{cm}$ $BC=5\text{cm}$ and $AC=6\text{cm}$ also write the steps of construction.
3. Draw a right triangle ABC in which $\angle B=90^\circ$ $AB=5\text{cm}$, $BC=4\text{cm}$ then construct another triangle ABC whose sides are $\frac{5}{3}$ times the corresponding sides of ΔABC .
4. Draw a pair of tangents to a circle of radius 5cm which are inclined to each other at an angle of 60° .
5. Draw a circle of radius 5cm from a point 8cm away from its centre construct the pair of tangents to the circle and measure their length.
6. Construct a triangle PQR in which $QR=6\text{cm}$ $\angle Q=60^\circ$ and $\angle R=45^\circ$. Construct another triangle similar to ΔPQR such that its sides are $\frac{5}{6}$ of the corresponding sides of ΔPQR .



AREAS RELATED TWO CIRCLES

KEY POINTS

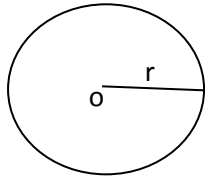
1. Circle: The set of points which are at a constant distance of r units from a fixed point o is called a circle with centre o .

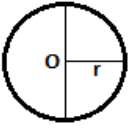
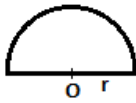
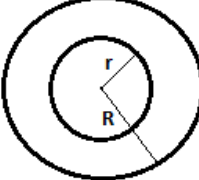

2. Circumference: The perimeter of a circle is called its circumference.
3. Secant: A line which intersects a circle at two points is called secant of the circle.
4. Arc: A continuous piece of circle is called and arc of the circle..
5. Central angle:- An angle subtended by an arc at the center of a circle is called its central angle.
6. Semi Circle: - A diameter divides a circle into two equal arc. Each of these two arcs is called a semi circle.
7. Segment :- A segment of a circle is the region bounded by an arc and a chord, including the arc and the chord.
8. Sector f of a circle: The region enclosed by and an arc of a circle and its two bounding radii is called a sector of the circle.
9. Quadrant:- One fourth of a circle disc is called a quadrant. The central ang of a quadrant is 90^0 .

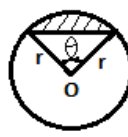
S.N	NAME	FIGURE	PERIMETER	AREA
1.	Circle		$2\pi r$ or πd	πr^2
2.	Semi- circle		$\pi r + 2r$	$\frac{1}{2} \pi r^2$
3.	Ring (Shaded region)		$2 \pi (r + R)$	$\pi(R^2 - r^2)$
4.	Sector of a circle		$l + 2r = \frac{\pi r \theta}{180^\circ} + 2r$	$\frac{\pi r^2 \theta}{360^\circ}$ or $\frac{1}{2} lr$
5.	Segment of a circle		$\frac{\pi r \theta}{180^\circ} + 2r \sin \frac{\theta}{2}$	$\frac{\pi r^2 \theta}{360^\circ} - \frac{1}{2} r^2 \sin \theta$

a. Length of an arc AB = $\frac{\theta}{360} 2 \pi r$

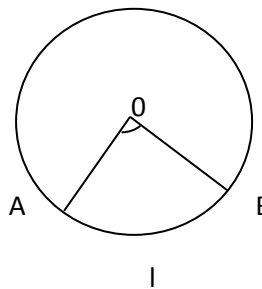

b. Area of major segment = Area of a circle – Area of minor segment

c. Distance moved by a wheel in
1 rotation = circumference of the wheel

d. Number of rotation in 1 minute

= Distance moved in 1 minute / circumference

LEVEL-I

1. If the perimeter of a circle is equal to that of square, then the ratio of their areas is

- i. $22/7$
- ii. $14/11$
- iii. $7/22$
- iv. $11/14$

[Ans-ii]

2. The area of the square that can be inscribed in a circle of 8 cm is

- i. 256 cm^2
- ii. 128 cm^2
- iii. $64\sqrt{2} \text{ cm}^2$
- iv. 64 cm^2

[Ans-ii]

3. Area of a sector to circle of radius 36 cm is $54 \pi \text{ cm}^2$. Find the length arc of the corresponding arc of the circle is

- i. $6 \pi \text{ cm}$
- ii. $3 \pi \text{ cm}$
- iii. $5 \pi \text{ cm}$
- iv. $8 \pi \text{ cm}$

[Ans –ii]

4. A wheel has diameter 84 cm. The number of complete revolution it will take to cover 792 m is.

- i. 100
- ii. 150
- iii. 200
- iv. 300

[Ans-iv]

5. The length of an arc of a circle with radius 12cm is $10 \pi \text{ cm}$. The central angle of this arc is .

- i. 120°
- ii. 60°
- iii. 75°
- iv. 150°

[Ans-iv]

6. The area of a quadrant of a circle whose circumference is 22 cm is

- i. $7/2 \text{ cm}^2$
- ii. 7 cm^2
- iii. 3 cm^2
- iv. 9.625 cm^2

[Ans-iv]

LEVEL-II

1. In figure 'o' is the centre of a circle. The area of sector OAPB is $5/18$ of the area of the circle find x.

[Ans 100]

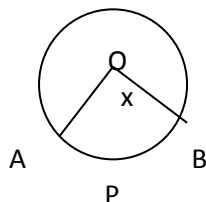

2. If the diameter of a semicircular protractor is 14 cm, then find its perimeter . [Ans-36 cm]

3. The radius of two circle are 3 cm and 4 cm . Find the radius of a circle whose area is equal to the sum of the areas of the two circles.

[Ans: 5 cm]

4. The length of the minute hand of a clock is 14 cm. Find the area swept by the minute hand in 5 minutes.

[Ans: $154/3$ cm²]

5. The radii of two circle are 3 cm and 4 cm . Find the radius of a circle whose area is equal to the sum of the areas of the two circles.

[Ans 5cm]

LEVEL-III

1. Find the area of the shaded region in the figure if $AC=24$ cm , $BC=10$ cm and o is the center of the circle (use $\pi = 3.14$)

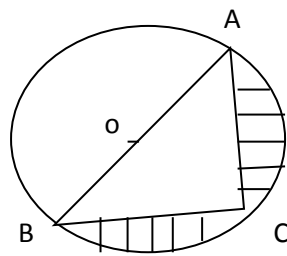

[Ans- 145.33 cm²]

2. The inner circumference of a circular track is 440m. The track is 14m wide. Find the diameter of the outer circle of the track. [Take $\pi = 22/7$]

[Ans-168]

3. Find the area of the shaded region.

[Ans: 4.71 cm²]

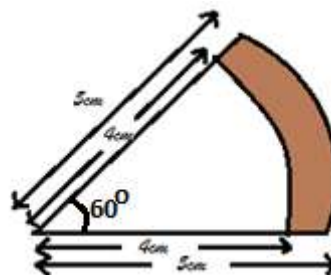

4. A copper wire when bent in the form of a square encloses an area of 121 cm² . If the same wire is bent into the form of a circle, find the area of the circle (Use $\pi=22/7$)

[Ans 154 cm²]

5. A wire is looped in the form of a circle of radius 28cm. It is rebent into a square form. Determine the side of the square (use $\pi = 22/7$)

[Ans-44cm]

LEVEL-IV

1. In fig, find the area of the shaded region [use $\pi = 3.44$]

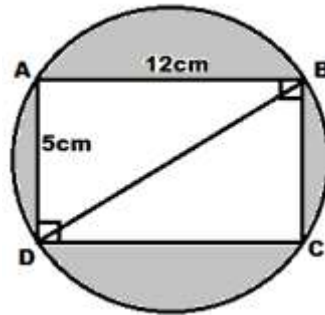

2. In fig find the shape of the top of a table in restaurant is that of a sector a circle with centre O and $\angle bod=90^\circ$. If $OB=OD=60\text{cm}$ find
- The area of the top of the table [Ans 8478 cm^2]
 - The perimeter of the table top (Take $\pi = 3.44$) [Ans 402.60 cm]

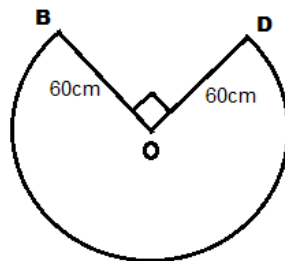

3. An arc subtends an angle of 90° at the centre of the circle of radius 14 cm. Write the area of minor sector thus form in terms of π .
[Ans $49\pi\text{ cm}^2$]
4. The length of a minor arc is $\frac{2}{9}$ of the circumference of the circle. Write the measure of the angle subtended by the arc at the center of the circle.
[Ans 80°]
5. The area of an equilateral triangle is $49\sqrt{3}\text{ cm}^2$. Taking each angular point as center, circle are drawn with radius equal to half the length of the side of the triangle. Find the area of triangle not included in the circles.
[Take $\pi\sqrt{3}=1.73$] [Ans 777cm^2]



SELF EVALUATION

- Two circles touch externally the sum of the areas is $130\pi\text{ cm}^2$ and distance between there center is 14 cm. Find the radius of circle.
- Two circle touch internally. The sum of their areas is $116\pi\text{ cm}^2$ and the distance between there centers is 6 cm. Find the radius of circles.
- A pendulum swings through an angle of 30° and describes and arc 8.8 cm in length. Find length of pendulum.
- What is the measure of the central angle of a circle?
- The perimeter and area of a square are numerically equal. Find the area of the square.

SURFACE AREAS AND VOLUMES

IMPORTANT FORMULA

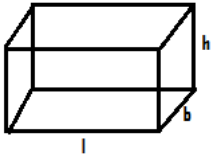
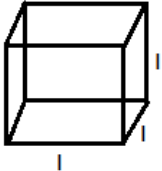
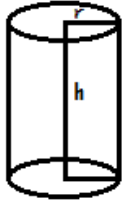
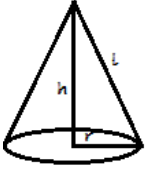
TAKE A LOOK

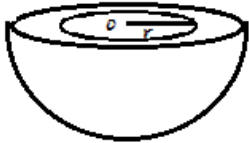
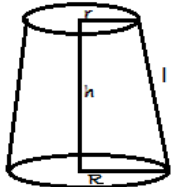
SNo	NAME	FIGURE	LATERAL CURVED SURFACE AREA	TOTAL SURFACE AREA	VOLUME	NOMENCLATURE
1	Cuboid		$2(l+b) \times h$	$2(l \times b + b \times h + h \times l)$	$l \times b \times h$	L=length, b=breadth, h=height
2	Cube		$4l^2$	$6l^2$	l^3	l=edge of cube
3	Right Circular Cylinder		$2\pi r h$	$2\pi r(r+h)$	$\pi r^2 h$	r= radius h=height
4	Right Circular Cone		$\pi r l$	$\pi r(l+r)$	$\frac{1}{3}\pi r^2 h$	r=radius of base, h=height, l=slant height = $\sqrt{r^2 + h^2}$
5	Sphere		$4\pi r^2$	$4\pi r^2$	$\frac{4}{3}\pi r^3$	r=radius of the sphere
6	Hemisphere		$2\pi r^2$	$3\pi r^2$	$\frac{2}{3}\pi r^3$	r=radius of hemisphere
7	Spherical shell		$2\pi(R^2 + r^2)$	$3\pi(R^2 - r^2)$	$\frac{4}{3}\pi(R^3 - r^3)$	R=External radius, r=internal radius
8	Frustum of a cone		$\pi l(R+r)$ where $l^2 = h^2 + (R-r)^2$	$\pi[R^2 + r^2 + l(R+r)]$	$\frac{\pi h}{3}[R^2 + r^2 + Rr]$	R and r = radii of the base, h=height, l=slant height.

9. Diagonal of cuboid = $\sqrt{l^2 + b^2 + h^2}$

10. Diagonal of Cube = $\sqrt{3}l$

(LEVEL - 1)

[1] The height of a cone is 60 cm. A small cone is cut off at the top by a plane parallel to the base and its volume is $\frac{1}{64}$ the volume of original cone. Find the height from the base at which the section is made?

ANS :- 45 cm

[2] Find the volume of the largest right circular cone that can be cut out from a cube of edge 4.2 cm?

ANS:- 19.4 cm³.

[3] A cubical ice cream brick of edge 22cm is to be distributed among some children by filling ice cream cones of radius 2cm and height 7cm up to its brim. How many children will get ice cream cones?

ANS :-363.

[4] Find the volume of the largest right circular cone that can be cut out from a cube of edge 4.9 cm is?

ANS :- 30.8cm³.

[5] The slant height of a frustum of a cone is 4 cm and the perimeter of its circular ends are 18cm and 6cm. Find the curved surface area of the frustum [use $\pi = \frac{22}{7}$].

ANS :- 48cm².

[6] A plumbline is a combination of which geometric shapes?

ANS :- A cone with hemisphere.

LEVEL - 2

[1] The slant height of the frustum of a cone is 5 cm . If the difference between the radii of its two circular ends is 4cm . write the height of the frustum.

ANS :- 3cm

[2] A cylinder, a cone and a hemisphere are of same base and of same height . Find the ratio of their volumes?

ANS :- [3:1:2].

[3] A cone of radius 4cm is divided into two parts by drawing a plane through the midpoint of its axis and parallel to its base, compare the volume of the two parts.

ANS :- 1:7

[4] How many spherical lead shots each having diameter 3cm can be made from a cuboidal lead solid of dimensions 9cm X 11cm X 12cm .

ANS :- 84

[5] Three metallic solid cubes whose edges are 3cm, 4cm, and 5cm are melted and converted into a single cube . Find the edge of the cube so formed?

ANS :- 6cm .

(LEVEL-3)

[1] How many shots each having diameter 4.2 cm can be made from a cuboidal lead solid of dimensions 66cm X 42cm X 21cm?

ANS:-1500

[2] Find the number of metallic circular disk with 1.5cm base diameter and of height 0.2 cm to be melted to form a right circular cylinder of height 10cm and diameter 4.5cm ?

ANS:-450

[3] From a solid cube of side 7cm, a conical cavity of height 7cm and radius 3cm is hollowed out. Find the volume of remaining solid?

ANS:-277cm³.

[4] A cubical block of side 7cm is surmounted by a hemisphere. What is the greatest diameter of the hemisphere can have? Find the surface area of the solid?

ANS:- 7cm, 332.5cm².

[5] A heap of rice is in the form of a cone of diameter 9m and height 3.5m. Find the volume of the rice. How much canvas cloth is required to just cover the heap?

ANS:-74.25m³, 80.61 m².

[6] A square field and an equilateral triangle park have equal perimeter. If the cost of ploughing the field at the rate of Rs 5/m² is Rs 720. Find the cost of maintain the park at the rate of Rs10/m²?

ANS:-Rs1108.48

(LEVEL -4)

[1] A well of diameter 3cm and 14m deep is dug. The earth, taken out of it, has been evenly spread all around it in the shape of a circular ring of width 4m to form an embankment. Find the height of embankment?

ANS:- $\frac{9}{8}$ m.

[2] 21 glass spheres each of radius 2cm are packed in a cuboidal box of internal dimensions 16cmX8cmX8cm and then the box is filled with water. Find the volume of water filled in the box?

ANS:-320cm³.

[3] The slant height of the frustum of a cone is 4cm and the circumferences of its circular ends are 18cm and 6cm. Find curved surface area and total surface area of the frustum.

ANS:-48cm², 76.63cm².

[4] A farmer connects a pipe of internal diameter 25cm from a canal into a cylindrical tank in his field, which is 12m in diameter and 2.5m deep. If water flows through the pipe at the rate of 3.6km/hr, in how much time will the tank be filled? Also find the cost of water, if the canal department charges at the rate of Rs0.07/m³?

ANS:-96min, Rs19.80

[5] A spherical glass vessel has a cylindrical neck 7cm long and 4cm in diameter. The diameter of the spherical part is 21cm. Find the quantity of water it can hold.

ANS:-4939cm³.

[6] The surface area of a solid metallic sphere is 616cm². It is melted and recast into a cone of height 28cm. Find the diameter of the base of the cone so formed.

ANS:-14cm.

SELF EVALUTION/HOTS QUESTIONS

[1] A spherical copper shell, of external diameter 18cm, is melted and recast into a solid cone of base radius 14cm and height 4cm. Find the inner diameter of the shell.

ANS:-16cm.

[2] A bucket is in the form of a frustum of a cone with a capacity of 12308.8cm^3 . The radii of the top and bottom circular ends of the bucket are 20cm and 12cm respectively. Find the height of the bucket and also the area of metal sheet used in making it [take $\pi = 3.14$]?

ANS:- $l = 14\text{cm}$, $AREA = 2160.32\text{cm}^2$.

[3] The volume of a solid metallic sphere is 616cm^3 . It is melted and recast into a cone of height 28cm. Find the diameter of the base of the cone so formed?

ANS:- 21cm.

[4] From a solid cylinder whose height is 8cm and radius 6cm, a conical cavity of height 8cm and of base radius 6cm, is hollowed out. Find the volume of the remaining solid correct to two places of decimals. Also find the total surface area of the remaining solid [take $\pi = 3.14$]?

ANS:- 603.19cm^3 , 603.19cm^2 .

[5] A cylindrical vessel, with internal diameter 10cm and height 10.5 cm is full of water. A solid cone of base diameter 7cm and height 6cm is completely immersed in water. Find the volume of :-

(i) water displaced out of the cylindrical vessel.

(ii) water left in the cylindrical vessel.

ANS:- (i): 77cm^3 , (ii) 748cm^3 .

[6] A wooden article was made by scooping out a hemisphere from each end of a solid cylinder. If the height of the cylinder is 20cm, and radius of the base is 3.5cm, find the total surface area of the article.

ANS:- 544cm^2 .

[7] A building is in the form of a cylinder surmounted by a hemispherical vaulted dome and contains $41\frac{19}{21}\text{m}^3$ of air. If the internal diameter of the building is equal to its total height above the floor, find the height of the building?

ANS:- 4m.

[8] A shuttlecock used for playing badminton has the shape of a frustum of a cone mounted on a hemisphere. The external diameters of the frustum are 5cm and 2cm, the height of the entire shuttlecock is 7cm. Find the external surface area.

ANS:- 74.38cm^2 .

PROBABILITY

KEY POINTS

- Probability:-** The theoretical probability of an event E, written as P(E) is defined as.
$$P(E) = \frac{\text{Number of outcomes Favorable to E}}{\text{Number of all possible outcomes of the experiment}}$$
Where we assume that the outcomes of the experiment are equally likely.
- The probability of a sure event (or certain event) is 1.
- The probability of an impossible event is 0.
- The probability of an Event E is number P (E) such that $0 \leq P(E) \leq 1$.
- Elementary events:- An event having only one outcome is called an elementary event. The sum of the probabilities of all the elementary events of an experiment is 1.
- For any event E, $P(E) + P(\bar{E}) = 1$, where \bar{E} stands for not E, E and \bar{E} are called complementary event.
- Performing experiments:-
 - Tossing a coin.
 - Throwing a die.
 - Drawing a card from deck of 52 cards.
- Sample space:-**The set of all possible outcomes in an experiment is called sample space.

LEVEL-1

- The probability of getting bad egg in a lot of 400 is 0.035. Then find the no. of bad eggs in the lot. [ans.14]
- Write the probability of a sure event. [ans.1]
- What is the probability of an impossible event. [ans.0]
- When a dice is thrown, then find the probability of getting an odd number less than 3. [ans. $\frac{1}{6}$]
- A girl calculates that the probability of her winning the third prize in a lottery is 0.08. If 6000 tickets are sold, how many ticket has she brought. [Ans.480]
- What is probability that a non-leap year selected at random will contain 53 Sundays. [Ans. $\frac{1}{7}$]
- A bag contains 40 balls out of which some are red, some are blue and remaining are black. If the probability of drawing a red ball is $\frac{11}{20}$ and that of black ball is $\frac{1}{5}$, then what is the no. of black ball. [Ans.10]
- Two coins are tossed simultaneously. Find the probability of getting exactly one head. [Ans. $\frac{1}{2}$]
- A card is drawn from a well suffled deck of 52 cards. Find the probability of getting an ace. [Ans. $\frac{1}{13}$]
- In a lottery, there are 10 prizes and 25 blanks. Find the probability of getting a prize. [Ans. $\frac{2}{7}$]

LEVEL-2

- Find the probability that a no. selected at random from the number 3,4,5,6,.....25 is prime. [Ans. $\frac{8}{23}$]
- A bag contains 5 red, 4 blue and 3 green balls. A ball is taken out of the bag at random. Find the probability that the selected ball is (a) of red colour (b) not of green colour. [Ans. $\frac{5}{12}, \frac{3}{4}$]

3. A card is drawn at random from a well-shuffled deck of playing cards. Find the probability of drawing
 (a) A face card (b) card which is neither a king nor a red card [Ans. $\frac{3}{13}, \frac{6}{13}$]
4. A dice is thrown once. What is the probability of getting a number greater than 4? [Ans. $\frac{1}{3}$]
5. Two dice are thrown at the same time. Find the probability that the sum of two numbers appearing on the top of the dice is more than 9. [Ans. $\frac{1}{6}$]
6. Two dice are thrown at the same time. Find the probability of getting different numbers on both dice. [Ans. $\frac{5}{6}$]
7. A coin is tossed two times. Find the probability of getting almost one head. [Ans. $\frac{3}{4}$]
8. Cards with numbers 2 to 101 are placed in a box. A card selected at random from the box. Find the probability that the card which is selected has a number which is a perfect square. [Ans. $\frac{9}{100}$]
9. Find the probability of getting the letter M in the word "MATHEMATICS". [Ans. $\frac{2}{11}$]

LEVEL-3

1. Cards bearing numbers 3,5,.....,35 are kept in a bag. A card is drawn at random from the bag. Find the probability of getting a card bearing (a) a prime number less than 15 (b) a number divisible by 3 and 5. [Ans. $\frac{5}{17}, \frac{2}{17}$]
2. Two dice are thrown at the same time. Find the probability of getting (a) same no. on the both side (b) different no. on both sides. [Ans. $\frac{1}{6}, \frac{5}{6}$]
3. A child game has 8 triangles of which three are blue and rest are red and ten squares of which six are blue and rest are red. One piece is lost at random. Find the probability of that is (a) A square (b) A triangle of red colour. [Ans. $\frac{5}{9}, \frac{5}{18}$]
4. Two dice are thrown simultaneously. What is the probability that:
 (a) 5 will not come up either of them? (b) 5 will come up on at least one? (c) 5 will come at both dice? [Ans. $\frac{25}{36}, \frac{11}{36}, \frac{1}{36}$]
5. The king, queen and jack of clubs are removed from a deck of 52 playing cards and remaining cards are shuffled. A card is drawn from the remaining cards. Find the probability of getting a card of (a) heart (b) queen (c) clubs [Ans. $\frac{13}{49}, \frac{3}{49}, \frac{10}{49}$]
6. A game consist of tossing a one-rupee coin 3 times and noting its outcome each time. Hanif wins if all the tosses give the same result, i.e., 3 heads or three tails and loses otherwise. Calculate the probability that hanif will lose the game. [Ans. $\frac{3}{4}$]
7. Cards bearing numbers 1,3,5,.....,37 are kept in a bag. A card is drawn at random from the bag. Find the probability of getting a card bearing
 (a) a prime number less than 15 [Ans. $\frac{5}{19}$]
 (b) a number divisible by 3 and 5. [Ans. $\frac{2}{19}$]

8. A dice has its six faces marked 0,1,1,1,6,6. Two such dice are thrown together and total score is recorded. (a) how many different scores are possible? (b) what is the probability of getting a total of seven?

[Ans. {a} 5 scores(0,1,2,6,7,12) {b} $\frac{1}{3}$]

Self Evaluation/Hots

1. Three unbiased coins are tossed together. find the probability of getting

(i) all heads

Ans. $\frac{1}{8}$

(ii) two heads

Ans. $\frac{3}{8}$

(iii) one heads

Ans. $\frac{3}{8}$

(iv) at least two heads

Ans. $\frac{1}{2}$

2. Two dice are thrown simultaneously .Find the probability of getting an even number as the sum.

Ans. $\frac{1}{2}$

3. Cards marked with the number 2 to 101 are placed in a box and mixed thoroughly . One card is drawn from the box . Find the probability that the number on the card is:

(i) An even number

Ans. $\frac{1}{2}$

(ii) A number less than 14

Ans. $\frac{3}{25}$

(iii) A number is perfect square

Ans. $\frac{9}{100}$

(iv) A prime number less than 20

Ans. $\frac{2}{25}$

4. Out of the families having three children, a family is chosen random. Find the probability that the family has

(i) Exactly one girl

Ans. $\frac{3}{8}$

(ii) At least one girl

Ans. $\frac{7}{8}$

(iii) At most one girl

Ans. $\frac{1}{2}$

5. Five card the ten, jack, queen, king, and ace of diamonds are well shuffled with their face downward . One card is picked up at random

(i) What is the probability that the card is the queen?

Ans. $\frac{1}{5}$

(ii) If the queen is drawn and put aside what is the probability that the second card picked up is

(a) an ace (b) a queen

Ans. $\frac{1}{4}, 0$

MODEL PAPER (SA-II) 2013

CLASS – X

SUB : MATHS

TIME ALLOWED : 3 HRS

M.M. = 90

General Instructions:

- (i) All questions are compulsory.
- (ii) The question paper consists of 34 questions divided into four sections A, B, C and D.
- (iii) Section A contains 8 questions of 1 marks each, which are MCQ. Section B contains 6 questions of 2 marks each, Section C contains 10 questions of 3 marks each and Section D contains 10 questions of 4 marks each.
- (iv) There is no overall choice in the paper. However, internal choice is provided in one question of 2 marks, three question of 3 marks and two questions of 4 marks.
- (v) Use of calculator is not permitted.

SECTION – A

Choose the correct option

- 1. The roots of a quadratic equation $px^2 + 6x + 1 = 0$ have real roots then value of p is
(A) $p \geq 9$ (B) $p < 9$ (C) $p \leq 9$ (D) None of these
- 2. The number of terms in the AP 7,13, 19,, 205 are
(A) 35 (B) 36 (C) 38 (D) 34
- 3. For what value of k, 10, k-2 are in A.P.
(A) $k=4$ (B) $k=3$ (C) $k=2$ (D) $k=1$
- 4. In the figure given, PA= 4 cm, AB= 9 cm, then value of PT is

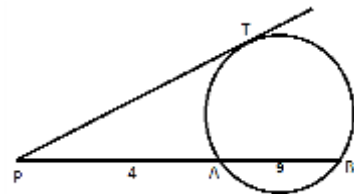

- (A) 9 cm (B) 4 cm (C) 6 cm (D) None of these
- 5. The height of a tower is $\sqrt{3}$ times of its shadow. The angle of elevation of the source of height is
(A) 30° (B) 60° (C) 45° (D) None of these
- 6. The probability of selecting a queen of hearts is
(A) $\frac{1}{4}$ (B) $\frac{1}{52}$ (C) $\frac{1}{13}$ (D) $\frac{12}{13}$
- 7. If the points P(1,2), Q(0,0) and R(a,b) are collinear, then
(A) $a=b$ (B) $a=2b$ (C) $2a=b$ (D) $a= - b$
- 8. A cone , a hemisphere and a cylinder stand on equal bases and have the same height then their volumes are in the ratio of
(A) 3:1:2 (B) 1:2:3 (C) 2:1:3 (D) 3:2:1

SECTION – B

- 9. Find the value of k, so that the quadratic equation $kx(x-2) + 6 = 0$ has two equal roots.
- 10. In the figure, a circle touches all the four sides of a quadrilateral ABCD whose sides are AB= 6 cm, BC = 9 cm and CD = 8 cm. Find the length of side AD.

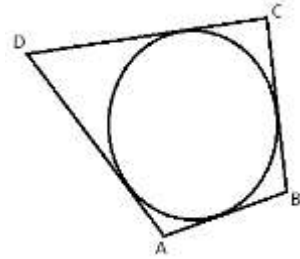

11. Prove that the tangents drawn at the ends of a diameter of a circle are parallel.
12. Draw a line segment AB of length 7 cm. Using ruler and compasses, find a point P on AB such that $\frac{AP}{AB} = \frac{3}{5}$
13. Two cubes each of volume 64 cm³ are joined end to end. Find the surface area of the resulting cuboid.
OR
A sphere of radius 8 cm is melted and recast into a right circular cone of height 32 cm. Find the radius of the base of the cone.
14. Calculate the area of the shaded region shown in the figure.

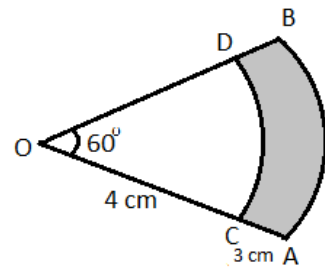

SECTION – C

15. Find the roots of the quadratics equation $3x^2 - 4\sqrt{3}x + 4 = 0$
16. The sum of three numbers of AP is 3 and their product is -35. Find the numbers.
OR
Which term of the AP 3, 10, 17, will be 84 more than its 13th term?
17. In the given figure, AOC is a diameter of the circle. If AB= 7cm, BC = 6 cm and CD = 2cm. Find the perimeter of the cyclic quadrilateral ABCD.

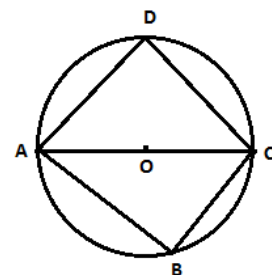

18. Draw a pair of tangents to a circle of radius 3 cm, which are inclined to each other at an angle of 60⁰.
OR
Draw a right triangle in which the sides(other than hypotenuse) are of lengths 4 cm and 3 cm. Then construct another triangle whose sides are $\frac{3}{5}$ times the corresponding sides of the given triangle.
19. The shadow of a tower standing on a level ground is found to be 40m longer when the sun's altitude is 30⁰ than when it is 60⁰. Find the height of the tower.
20. A bag contains 5 red balls and some blue balls. If the probability of drawing a blue ball is double that of a red ball, determine the number of blue balls in the bag.
OR
What is the probability that a leap year, selected at random will contain 53 Sundays?

21. Find the ratio in which the segment joining the points (-3,10) and (6,-8) is divided by (-1,6)
22. Find the area of the quadrilateral whose vertices taken in order are (-4,-2); (-3,-5); (3,-2);(2,3)
23. The circumference of a circle is 88 cm. Find the area of the sector, whose angle at the centre is 45° .
24. A drinking glass is in the shape of a frustum of a cone of height 14 cm. The diameters of its two circular ends are 4 cm and 2 cm. Find the capacity of the glass.

SECTION – D

25. Solve for x.

$$\frac{1}{a+b+x} = \frac{1}{a} + \frac{1}{b} + \frac{1}{x}, \quad a+b \neq 0$$
 OR
 A plane left 30 minutes later than the schedule time and in order to reach its destination 1500 km away in time, it has to increase its speed by 250 km/hr from its usual speed. Find its usual speed.
26. Find the sum of all natural numbers between 250 and 1000 which are exactly divisible by 3.
27. Which term of the sequence $20, 19\frac{1}{4}, 18\frac{1}{2}, 17\frac{3}{4}, \dots$ is the first negative term?
28. A circle is touching the side BC of $\triangle ABC$ at P and touching AB and AC produced at Q and R respectively. Prove that $AQ = \frac{1}{2}$ (Perimeter of $\triangle ABC$)
 OR
 If all the side of a parallelogram touch a circle, show that the parallelogram is a rhombus.
29. From the top of a building 60m. high the angles of depression of the top and the bottom of a tower are observed to be 30° and 60° . Find the height of the tower.
30. The king, queen and jack of clubs are removed from a deck of 52 playing cards and the well shuffled. One card is selected from the remaining cards. Find the probability of getting
 (i) a king (ii) a heart (iii) a club (iv) the '10' of hearts.
31. Find the value of 'k' for the points (7,-2);(5,1);(3,k); are collinear
32. A gulab jamun, contains sugar syrup up to about 30% of its volume . Find approximately, how much syrup would be found in 45 gulab jamuns, each shaped like a cylinder with two hemispherical ends with length 5 cm and diameter 2.8 cm.
33. Water is flowing at the rate of 5 km/hr through a pipe of diameter 14 cm into a rectangular tank which is 50 m long and 44 m wide. Determine the time in which the level of the water in the tank will rise by 7 cm.
34. A toy is in the form of a cone mounted on hemisphere of diameter 7 cm. The total height of the toy is 14.5 m. Find the volume and the total surface area of the toy.

SA-II

MARKING SCHEME

CLASS-X (MATHS)

EXPECTED ANSWERS/VALUE POINTS

MARKING SCHEME FOR SA-2 SECTION-A

Q. No.	Solution	Marks
1.	(C)	1
2.	(D)	1
3.	(A)	1
4.	(C)	1
5.	(B)	1
6.	(B)	1
7.	(C)	1
8.	(B)	1

SECTION - B

9.	Since, we know that for equal roots $D=0$ Or, $b^2-4ac=0$ Or, $(-2k)^2-4 \times k \times 6=0$ Or, $4k^2-24k=0$ Or, $4k(k-6)=0$ Or, $4k=0$, or $k-6=0$ Or, $k=0$, or $k=6$ Or, $k=0, 6$ Ans.	1
10.	Here the circle touches the all sides of the Quadrilateral So, $AB+CD=AD+BC$ Or, $6+8=AD+9$ Or, $AD=14-9=5$ cm Ans.	1
11.	Required Fig., Given and to prove Proof:	1
12.	Drawing $\overline{AB}=7$ cm Correct division by any method Correct location of point i.e; $AP/AB=3/5$	1
13.	\therefore vol. of the cube= side^3 or, $64 = \text{side}^3$ \therefore side of the cube= $\sqrt[3]{64} = 4$ cm Now S.A of the resultant cuboid= $2(lb+bh+hl)$ $=2(8 \times 4+4 \times 4+4 \times 8)$ $=2(32+16+32)$ $=2(80)$ $=160 \text{ cm}^2$ Ans. Or	1
	By question Vol. of the cone = vol. of the sphere Or, $\frac{1}{3}\pi r^2 h = \frac{4}{3}\pi R^3$ Or, $r^2 \times 32 = 4 \times 8 \times 8 \times 8$ $\therefore r = 8$ cm so, the radius of the base of the cone= 8 cm Ans.	1
14.	Ar. of the shaded portion = $\frac{\theta}{360} \times \pi(R^2-r^2)$ $= (60/360) \times (22/7) (7^2-4^2)$	1

$$= 1/6 \times 22/7 \times 33$$

$$= 17.28 \text{cm}^2 \text{ Ans.}$$

15. $\therefore x = \frac{-b \pm \sqrt{b^2 - 4ac}}{2a}$ and putting the correct value

$$= \frac{-(-4\sqrt{3}) \pm \sqrt{(-4\sqrt{3})^2 - 4 \times 3 \times 4}}{2 \times 3}$$

$$= \frac{4\sqrt{3} \pm 0}{6}$$

$$= \frac{2}{\sqrt{3}}, \frac{2}{\sqrt{3}} \text{ Ans}$$

16. Let the three nos. of the AP are $\alpha - \beta, \alpha, \alpha + \beta$

By question,

$$\alpha - \beta + \alpha + \alpha + \beta = 3$$

or, $3\alpha = 3$

$\therefore \alpha = 1$

And $(\alpha - \beta) \times \alpha \times (\alpha + \beta) = -35$

or, $\alpha(\alpha^2 - \beta^2) = -35$

Putting the value of $\alpha = 1$ then

$$1(1 - \beta^2) = -35$$

or, $-\beta^2 = -36$

or, $\beta = \pm 6$

hence the no. are 7, 1, -5, or, -5, 1, 7 respectively. Ans.

Or

Here $t_{13} = a + 12d$

$$= 3 + 12(7)$$

$$= 87$$

Let $t_n = t_{13} + 84$

or, $a + (n-1)d = 87 + 84$

or, $3 + (n-1)7 = 171$

or, $(n-1) = 168/7 = 24$

or, $n = 25$

\therefore the required term = 25th Ans.

17. Since, AOC is a diameter of the circle.

$$\therefore \angle ABC = 90^\circ$$

so, in right triangle ABC

$$AC^2 = 7^2 + 6^2$$

$$= 85$$

Similarly, $\angle ADC = 90^\circ$

So, in right triangle ADC

$$AD^2 = AC^2 - CD^2$$

$$= 85 - 4$$

$$= 81$$

$\therefore AD = 9 \text{ cm}$

So, the perimeter of the cyclic Quad. ABCD = $(7 + 6 + 2 + 9) \text{ cm}$

$$= 24 \text{cm Ans.}$$

18. Constructing 120° at the centre with radii

Drawing tangents at the end of radii

Angle 60° between both tangents at the intersection point

Or

For drawing correct triangle

For correct construction steps for making similar triangle

Required triangle whose sides are $3/5$ times the corresponding sides

19.

For correct figure.

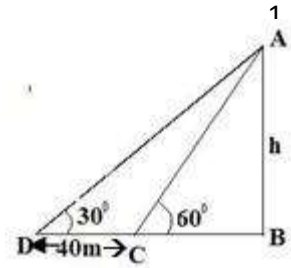

In triangle ABC, $\tan 60^\circ = \frac{AB}{BC}$

Or $\sqrt{3} = \frac{h}{x}$

$\sqrt{3} = \frac{h}{x}$

$\therefore h = \sqrt{3}x$

Now in triangle ABD

$\tan 30^\circ = \frac{h}{40+x}$

or, $\frac{1}{\sqrt{3}} = \frac{\sqrt{3}x}{40+x}$

or, $x = 20$

$\therefore h = 20\sqrt{3} \text{ m}$ Ans.

20 Here, no. Of red balls=5

let no. Of blue balls = x

$\therefore \text{Total no. of balls} = (5 + x)$

By question,

$P(B) = 2P(R)$

or, $\frac{x}{5+x} = 2 \left(\frac{5}{5+x} \right)$

or, $x = 10$

so, No. Of blue balls=10 Ans.

or

In a leap year =366 days= 52 weeks and 2 days

The remaining two days can be

- (i) SUN, MON (v) THU, FRI
- (ii) MON, TUE (vi) FRI, SAT
- (iii) TUE, WED (vii) SAT, SUN
- (iv) WED, THU

There are total seven possibilities i.e. $n(s) = 7$

and $n(E) = 2$ i.e. SUN, MON & SAT, SUN

$\therefore P(E) = \frac{n(E)}{n(s)} = \frac{2}{7}$ Ans.

21.

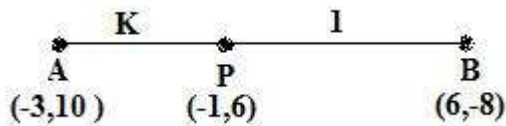

By question, $-1 = \frac{6k-3 \times 1}{k+1}$

$k = \frac{2}{7}$

Hence required ration is 2:7

22.

$$\begin{aligned} \text{Ar. Of } \triangle ABC &= \frac{1}{2} [x_1(y_2 - y_3) + x_2(y_3 - y_1) + x_3(y_1 - y_2)] \\ &= \frac{1}{2} [-4(-5 + 2) + (-3)(-2 + 2) + (-4)(-2 - 3)] \\ &= \frac{21}{2} \text{ unit}^2 \end{aligned}$$

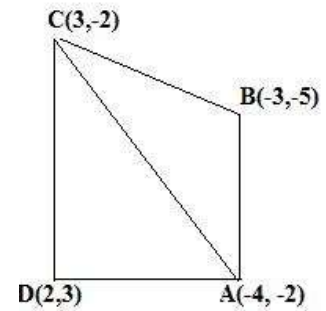

$$\begin{aligned} \text{Ar. Of } \triangle CDA &= \frac{1}{2} [3(3 + 2) + 2(-2 + 2) + (-4)(-2 - 3)] && 1 \\ &= \frac{35}{2} \text{ unit}^2 \end{aligned}$$

so, Ar. Of qua. ABCD = $\frac{21}{2} + \frac{35}{2} = 28 \text{ unit}^2$ Ans. 1

23. Since, the Circumference of the circle = 88 cm 1

or, $2\pi r = 88$

$$\therefore r = \frac{88 \times 7}{44} = 14 \text{ cm}$$

So, Ar. of the required sector = $\frac{\theta}{360} \pi r^2$ 1

$$= \frac{45}{360} \times \frac{22}{7} \times 14 \times 14$$

1

$$= 77 \text{ cm}^2$$

24. Vol. Of Glass (Shaped frustum of a cone) = $\frac{1}{3} \pi (R^2 + r^2 + Rr)h$ 1

$$= \frac{1}{3} \times \frac{22}{7} (2^2 + 1^2 + 2 \times 1)14$$

1

$$= \frac{1}{3} \times \frac{22}{7} \times 7 \times 14$$

1

$$= 102.67 \text{ cm}^3$$

SECTION - D

25. $\frac{1}{a+b+x} - \frac{1}{x} = \frac{1}{a} + \frac{1}{b}$ 1

or, $\frac{x-(a+b+x)}{x(a+b+x)} = \frac{a+b}{ab}$ 1

or, $\frac{-(a+b)}{x(a+b+x)} = \frac{a+b}{ab}$ 1

or, $x(a+b+x) + ab = 0$

or, $x^2 + ax + bx + ab = 0$

or, $x(x+a) + b(x+a) = 0$ 1

or, $(x+a)(x+b) = 0$

$\therefore x = -a \text{ or } x = -b$ Ans.

Or

Let the usual speed of the plane be x km/hr. 1

Then, By question,

$$\frac{1500}{x} - \frac{1500}{x+250} = \frac{1}{2}$$

or, $x^2 + 250x - 750000 = 0$ 1

or, $(x+1000)(x-750) = 0$ 1

Or, $x = -1000$ (rejected) or, $x = 750$ 1

Hence, the usual speed of the plane is 750 km/hr. Ans.

26. Required nos. are 252, 255, 258, 999 1

Here, $a + (n-1)d = 999$ 1

or, $252 + (n-1)3 = 999$ 1

$\therefore n = 250$

So, Required sum = $s_n = \frac{n}{2} \{a + l\} = \frac{250}{2} (252 + 999) = 156375$. Ans. 1

27. Let the n^{th} term of the given AP be the first negative term. 1

Then $a_n < 0$

or, $a + (n-1)d < 0$ 1

or, $20 + (n-1)(-\frac{3}{4}) < 0$

or, $83 - 3n < 0$ 1

or, $3n > 83$

or, $n > \frac{83}{3}$

or, $n > 27\frac{2}{3}$

$\therefore n \geq 28$

Thus, 28th term of the given sequence is the first negative term. Ans.

28. Required fig.

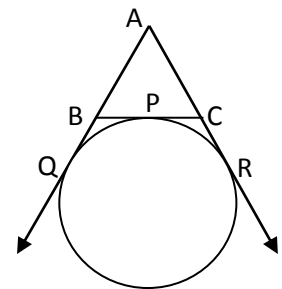

Since, tangents from an external point to a circle are equal in length

$\therefore BP = BQ$ -----(i)

$CP = CR$ -----(ii)

And, $AQ = AR$ -----(iii)

or, $AB + BQ = AC + CR$

or, $AB + BP = AC + CP$

Now, Perimeter of $\Delta ABC = AB + BC + AC$
 $= AB + (BP + PC) + AC$
 $= (AB + BP) + (AC + PC)$
 $= 2(AB + BP)$
 $= 2(AB + BQ)$
 $= 2AQ$

$\therefore AQ = \frac{1}{2}(\text{Perimeter of } \Delta ABC)$ Proved.

Or

Required fig.

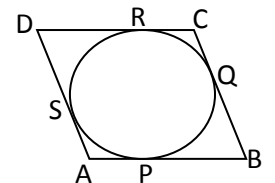

We know that the tangents to a circle from an external point are equal in length.

$\therefore AP = AS$ -----(i)

$BP = BQ$ -----(ii)

$CR = CQ$ -----(iii)

$DR = DS$ -----(iv)

Adding (i), (ii), (iii) & (iv), we get

$(AP + BP) + (CR + DR) = (AS + DS) + (BQ + CQ)$

or, $AB + CD = AD + BC$

or, $2AB = 2BC$

or, $AB = BC$

so, $AB = BC = CD = AD$

\Rightarrow ABCD is a rhombus. Proved.

29. For correct fig.

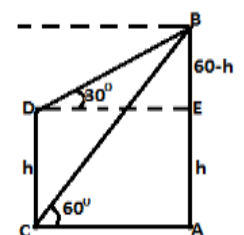

Let AB = Building, CD = Tower

In ΔDEB ,

$\tan 30^\circ = \frac{BE}{DE}$

1
1
1
1
1
1
1
1
1
1
1
1

or, $\frac{1}{\sqrt{3}} = \frac{60-h}{x}$
 $\therefore x = (60-h)\sqrt{3}$ -----(i)

In, ΔCAB ,

$\tan 60^\circ = \frac{AB}{CA}$
or, $\sqrt{3} = \frac{60}{x}$

$\therefore x = \frac{60}{\sqrt{3}}$ -----(ii)

By (i) & (ii)

$(60-h)\sqrt{3} = \frac{60}{\sqrt{3}}$
 $h=40$ m

Thus, the height of the tower is 40m. Ans.

30 Here, $n(s) = 49$

(i) $P(E_1) = \frac{n(E_1)}{n(s)} = \frac{3}{49}$

(ii) $P(E_2) = \frac{n(E_2)}{n(s)} = \frac{13}{49}$

(iii) $P(E_3) = \frac{n(E_3)}{n(s)} = \frac{10}{49}$

(iv) $P(E_4) = \frac{n(E_4)}{n(s)} = \frac{1}{49}$

31 Three points are collinear if $\frac{1}{2}[x_1(y_2 - y_3) + x_2(y_3 - y_1) + x_3(y_1 - y_2)] = 0$

or, $\frac{1}{2}[7(1 - k) + 5(k + 2) + 3(-2 - 1)] = 0$

or, $-2k + 8 = 0$

or, $k=4$

$\therefore k = 4$ Ans.

32. For correct Fig.

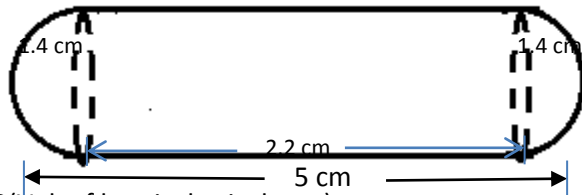

Vol. of 1 Gulab Jamun = Vol. of cylindrical part + 2(Vol. of hemispherical part)

$= \pi r^2 h + 2 \left(\frac{2}{3} \pi r^3 \right)$

$= \pi r^2 \left(h + \frac{4}{3} r \right)$

$= \frac{22}{7} \times 1.4 \times 1.4 \left[2.2 + \frac{4}{3} \times 1.4 \right]$

$= 25.05 \text{ cm}^3$

So, vol. of 45 gulab jamuns = $45 \times 25.05 = 1127.28 \text{ cm}^3$

Hence, Vol. of sugar syrup = $\frac{30}{100} \times 1127.28 = 338.18 \text{ cm}^3 = 338 \text{ cm}^3$ (approx.)

33 Let the level of the water in the tank will rise by 7cm in x hrs

So, vol of the water flowing through the cylindrical pipe in x hrs = $\pi r^2 h$

$= \frac{22}{7} \times \left(\frac{7}{100} \right)^2 \times 5000 x \text{ m}^3$

$= 77 x \text{ m}^3$

Also, Vol of water that falls into the tank in x hrs = $50 \times 44 \times \frac{7}{100} \text{ m}^3 = 154 \text{ m}^3$

By ques $77 x = 154$

$x = 2$

So, the level of the water in the tank will rise by 7 cm in 2 hours

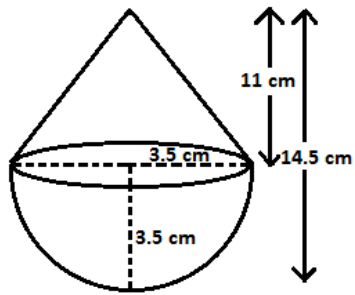

for correct figure 1 marks

$$\text{Radius of hemisphere} = 7/2 = 3.5 \text{ cm}$$

$$\begin{aligned} \text{Height of cone} &= (14.5 - 3.5) \\ &= 11 \text{ cm} \end{aligned}$$

$$\text{Slant height of cone} = \sqrt{r^2 + h^2}$$

$$= \sqrt{(3.5)^2 + (11)^2}$$

$$= 11.55 \text{ cm}$$

1

Now, vol of toy = Vol of hemisphere + Vol of cone

$$= \frac{2}{3}\pi r^3 + \frac{1}{3}\pi r^2 h$$

$$= \frac{1}{3}\pi r^2 (2r + h)$$

$$= \frac{1}{3} \times \frac{22}{7} \times \frac{7}{2} \times \frac{7}{2} (2 \times \frac{7}{2} + 11) \text{ cm}^3$$

$$= 231 \text{ cm}^3$$

1

And, TSA of the Toy = SA of hemisphere + SA of cone

$$= 2\pi r^2 + \pi r l$$

$$= \pi r (2r + l)$$

$$= \frac{22}{7} \times \frac{7}{2} (2 \times \frac{7}{2} + 11.55)$$

$$= 204.05 \text{ cm}^2$$

1

ACTIVITES (TERM-I)

(Any Eight)

- Activity1: To find the HCF of two Numbers Experimentally Based on Euclid Division Lemma
- Activity2: To Draw the Graph of a Quadratic Polynomial and observe:
- i. The shape of the curve when the coefficient of x^2 is positive
 - ii. The shape of the curve when the coefficient of x^2 is negative
 - iii. Its number of zero
- Activity3: To obtain the zero of a linear Polynomial Geometrically
- Activity4: To obtain the condition for consistency of system of linear Equations in two variables
- Activity5: To Draw a System of Similar Squares, Using two intersecting Strips with nails
- Activity6: To Draw a System of similar Triangles Using Y shaped Strips with nails
- Activity7: To verify Basic proportionality theorem using parallel line board
- Activity8: To verify the theorem: Ratio of the Areas of Two Similar Triangles is Equal to the Ratio of the Squares of their corresponding sides through paper cutting.
- Activity9: To verify Pythagoras Theorem by paper cutting, paper folding and adjusting (Arranging)
- Activity10: Verify that two figures (objects) having the same shape (and not Necessarily the same size) are similar figures. Extend the similarity criterion to Triangles.
- Activity11: To find the Average Height (in cm) of students studying in a school.
- Activity12: To Draw a cumulative frequency curve (or an ogive) of less than type .
- Activity13: To Draw a cumulative frequency curve (or an ogive) of more than type.

ACTIVITES (TERM-II)

(Any Eight)

- Activity1: To find Geometrically the solution of a Quadratic Equation $ax^2+bx+c=0$, $a \neq 0$ (where $a=1$) by using the method of computing the square.
- Activity2: To verify that given sequence is an A.P (Arithmetic Progression) by the paper Cutting and Paper Folding.
- Activity3: To verify that $\sum n = \frac{n(n+1)}{2}$ by Graphical method
- Activity4: To verify experimentally that the tangent at any point to a circle is perpendicular to the Radius through that point.
- Activity5: To find the number of Tangent from a point to the circle
- Activity6: To verify that lengths of Tangents Drawn from an External Point, to a circle are equal by using method of paper cutting, paper folding and pasting.
- Activity7: To Draw a Quadrilateral Similar to a given Quadrilateral as per given scale factor (Less than 1)
- Activity8: (a) To make mathematical instrument clinometer (or sextant) for measuring the angle of elevation/depression of an object
(b) To calculate the height of an object making use of clinometers(or sextant)
- Activity9: To get familiar with the idea of probability of an event through a double color card experiment.
- Activity10: To verify experimentally that the probability of getting two tails when two coins are tossed simultaneously is $\frac{1}{4}=0.25$ (By eighty tosses of two coins)
- Activity11: To find the distance between two objects by physically demonstrating the position of the two objects say two Boys in a Hall, taking a set of reference axes with the corner of the hall as origin.
- Activity12: Division of line segment by taking suitable points that intersects the axes at some points and then verifying section formula.
- Activity13: To verify the formula for the area of a triangle by graphical method .
- Activity14: To obtain formula for Area of a circle experimentally.
- Activity15: To give a suggestive demonstration of the formula for the surface Area of a circus Tent.
- Activity16: To obtain the formula for the volume of Frustum of a cone.

PROJECTS

- Project 1 : Efficiency in packing
 - Project 2 : Geometry in Daily Life
 - Project 3: Experiment on probability
 - Project 4: Displacement and Rotation of a Geometrical Figure
 - Project 5: Frequency of letters/ words in a language text.
 - Project 6: Pythagoras Theorem and its Extension
 - Project 7: Volume and surface area of cube and cuboid.
 - Project 8: Golden Rectangle and golden Ratio
 - Project 9 : Male-Female ratio
 - Project 10 : Body Mass Index(BMI)
 - Project 11 : History of Indian Mathematicians and Mathematics
 - Project 12 : Career Opportunities
 - Project 13 : π (Pie)
- Project Work Assignment (Any Eight)

ACTIVITY- 1

TOPIC:- Prime factorization of composite numbers.

OBJECTIVE:- To verify the prime factorization 150 in the form $5^2 \times 3 \times 2$ i.e $150 = 5^2 \times 3 \times 2$.

PRE-REQUISITE KNOWLEDGE:- For a prime number P, P^2 can be represented by the area of a square whose each side of length P units.

MATERIALS REQUIRED:-

- i. A sheet of graph paper (Pink / Green)
- ii. Colored (black) ball point pen.
- iii. A scale

TO PERFORM THE ACTIVITY:-

Steps:-

1. Draw a square on the graph paper whose each side is of length 5 cm and then make partition of this square into 25 small squares as shown in fig 1.1 each small square has its side of length 1cm.

Here, we observe that the area of the square having side of length 5 cm $= 5^2 \text{ cm}^2 = 25 \text{ cm}^2$

2. As shown in Fig 1.2 draw three equal squares where each square is of same size as in figure 1.1 then the total area in the fig1.2
 $= 5^2 + 5^2 + 5^2 \text{ cm}^2$
 $= 5^2 \times 3 \text{ cm}^2$ ie, 75 cm^2

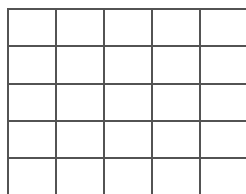

Fig=1.1

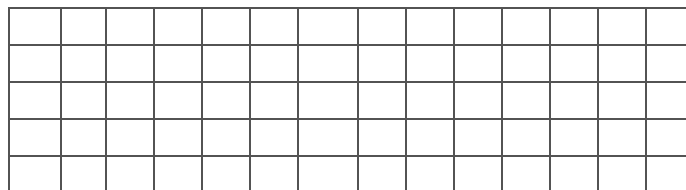

Fig=1.2

3. As shown in fig 1.3 draw six equal square where each square is as same size as in Fig 1.1 Here , three squares are in one row and three squares in the second row.

We observe that the total area of six squares

$$\begin{aligned} &= 5^2 \times (3+3) \text{ cm}^2 \\ &= 5^2 \times 3 \times 2 \text{ cm}^2 \end{aligned}$$

Also observe that the total area
 $=75\text{cm}^2+75\text{cm}^2=150\text{cm}^2$

Hence, we have verified that

$$150=5^2 \times 3 \times 2$$

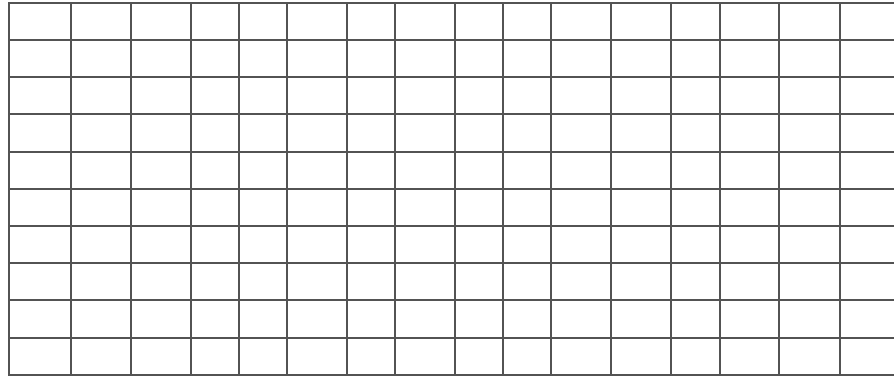

Fig-1.3

ACTIVITY-2

TOPIC:- Ratio of the areas of two similar triangles

STATEMENT:- The ratio of the area of two similar triangle is equal to the ratio of the squares of their corresponding sides.

OBJECTIVE:- To verify the above statement through activity.

PRE-REQUISITE KNOWLEDGE:-

1. The concept of similar triangles.
2. Division of a line segment into equal parts.
3. Construction of lines parallel to given line.

MATERIAL REQUIRED:-

1. White paper sheet
2. Scale /Rubber
3. Paint box
4. Black ball point pen or pencil

TO PERFORM THE ACTIVITY:-

STEPS:-

1. On the poster paper sheet, draw two similar triangle ABC and DEF. We have the ratio of their corresponding sides same and let as have
 $AB: DE= BC: EF=CA: FD=5:3$

ie , $AB/DE=5/3$, $BC/EF=5/3$, $CA/FD =5/3$,

ie $DE =3/5 AB$, $EF=3/5 BC$, $FD=3/5 CA$
2. Divide each side of ΔABC into 5 equal parts and those of ΔDEF into 3 equal parts as shown in Fig (i) and (ii).
3. By drawing parallel lines as shown in Fig (i) and (ii)., we have partition ΔABC into 25 smaller triangle of same size and also each smaller triangle in fig (i) has same size and as that of the smaller triangle fig (ii).
4. Paint the smaller triangle as shown in Fig (i) and (ii)..

OBSERVATION:-

1. Area of $\Delta ABC=$ Area of 25 smaller triangle in fig (i)=25 square unit

Where area of one smaller triangle in fig (i)=P (square unit)

2. Area of $\triangle DEF$ =Area of a smaller triangle in Fig (ii)=9p where area of one smaller triangle in fig (ii)=P square units.

3.
$$\frac{\text{Area of } \triangle ABC}{\text{Area of } \triangle DEF} = \frac{25 P}{9P} = \frac{25}{9}$$

4.
$$\frac{(AB)^2}{(DE)^2} = \frac{(AB)^2}{(3/5AB)^2} = \frac{(AB)^2}{9/25(AB)^2} = \frac{25}{9}$$

Similarly

$$\frac{(BC)^2}{(EF)^2} = \frac{25}{9} \quad \text{and} \quad \frac{(CA)^2}{(FD)^2} = \frac{25}{9}$$

5. From steps (3) and (4) , we conclude that

$$\frac{\text{Area of } \triangle ABC}{\text{Area of } \triangle DEF} = \frac{(AB)^2}{(DE)^2} = \frac{(BC)^2}{(EF)^2} = \frac{(CA)^2}{(FD)^2}$$

Hence the ratio of the areas of two similar triangles is equal to the ratio of the squares of their corresponding sides.

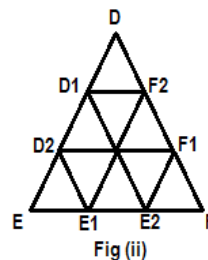
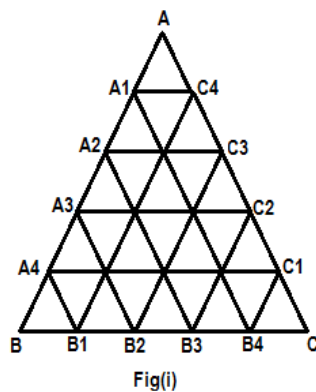

ACTIVITY-3

TOPIC:- Trigonometric identities.

STATEMENT:- $\sin^2\theta + \cos^2\theta=1, 0^\circ < \theta < 90^\circ$

OBJECTIVE: - To verify the above identity

PRE-REQUISITE KNOWLEDGE:- In a right angled triangle.

$$\sin \theta = \frac{\text{Side opposite to angle } \theta}{\text{Hypotenuse of the triangle}}$$

$$\cos \theta = \frac{\text{Side adjacent to angle } \theta}{\text{Hypotenuse of the triangle}}$$

MATERIAL REQUIRED:-

1. Drawing sheet
2. Black ball point pen
3. Geometry box
4. Scale

TO PERFORM THE ACTIVITY

Step:-

1. On the drawing sheet, draw horizontal ray AX .
2. Construct any arbitrary $\angle CAX= \theta$ (say)
3. Construct AC=10 cm.
4. From C draw $CB \perp AX$.
5. Measure the length sides of sides AB and BC of the right angled ΔABC (see fig)
6. We measure that AB=8.4 cm (approx) and BC=5.4 cm (approx)

OBSERVATION

1. $\sin \theta = BC/AC = 5.4/10 = .54$ (Approx)
2. $\cos \theta = AB/AC = 8.4/10 = .84$ (approx)
3. $\sin^2 \theta + \cos^2 \theta = (.54)^2 + (.84)^2$
 $= .2916 + .7056$
 $= .9972$ (Approx)

ie. $\sin^2 \theta + \cos^2 \theta$ is nearly equal to 1. Hence the identity is verified.

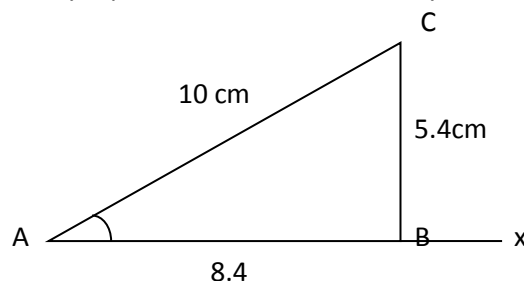

ACTIVITY-4

Topics:- Measure of the central tendencies of a data.

STATEMENT:- We have an empirical relationship for statistical data as $3 \times \text{median} = \text{Mode} + 2 \times \text{mean}$.

OBJECTIVE :- To verify the above statement for a data.

PRE-REQUISITE KNOWLEDGE:-

Method to find central tendencies for grouped data.

MATERIAL REQUIRED:-

1. A data about the heights of students of a class and arranged in grouped form.
2. A ball point pen.
3. A scale.

TO PERFORM THE ACTIVITY:-

Step:-

1. Count the number of girl students in the class. The number is 51
2. Record the data about their height in centimeter.
3. Write the data in grouped form as below:-

Height in cm	135-140	140-145	145-150	150-155	155-160	160-165	Total no of girls
Number of girls	4	7	18	11	6	5	51

4. On three different sheets of paper find mean height on the sheet of paper , median height on the second and the modal height on the third sheet of paper.
5. Let us find mean by step deviation method:-

Class of heights (in cm)	Frequency p	Class mark x_i	$U_i = \frac{x_i - 147.5}{5}$ $a = 147.5, h = 5$	Fi x ui
135-140	4	137.5	-2	-8
140-145	7	142.5	-1	-7
145-150	18	147.5	0	0
150-155	11	152.5	1	11
155-160	6	157.5	2	12
160-165	5	162.5	3	13
	$\sum f_i = 51$			$\sum f_i u_i = 51$

$$\text{Mean} = a + h \times \frac{\sum f_i u_i}{\sum f_i} = 147.5 + 5 \times \frac{23}{51} = 147.5 + 115/51$$

$$= (147.5 + 2.255) \text{cm} = 149.755 \text{cm}$$

6. Let us find median of the data:-

Class of height (in cm)	Frequency number of girls	Cumulative frequency
135-140	4	4
140-145	7	11=cf
145-150	18=f	29
150-155	11	40
155-160	6	46
160-165	5	51
Total	$n \sum f_i = 51$	

$$n/2 = 25.5$$

we have median class (145-150) it gives $l=145, h=5, f=18, cf=11$

$$\text{median} = l + \left\{ \frac{\frac{n}{2} - cf}{f} \right\} \times h = 145 + \left\{ \frac{25.5 - 11}{18} \right\} \times 5$$

$$= 145 + \frac{14.5 \times 5}{18}$$

$$= 145 + 4.028$$

$$= 149.028 \text{cm}$$

7. Let us find mode of the data:-

Class of heights (in cm)	FREQUENCY (No of Girls)
135-140	4
140-145	7=f ₁
145-150	18=f _m
150-155	11=f ₂
155-160	6
160-165	5
Total	51

(Modal class)

Modal class is 145-150

Thus $l=145, h=5, f_m=18, f_1=7, f_2=11$

$$\text{Mode} = H \left\{ \frac{f_m - f_1}{2f_m - f_1 - f_2} \right\} \times h = 145 + \left\{ \frac{18 - 7}{36 - 7 - 11} \right\} \times 5$$

$$= 145 + 55/18 = 145 + 3.055$$

$$= 148.055 \text{ cm}$$

8. CONCLUSION:-

Mean=149.755, median=149.028 and mode=148.055

$3 \times \text{median} = 3 \times 149.028 = 447.084$

$\text{Mode} + 2 \times \text{mean} = 148.055 + 2 \times 149.755$

$= 148.055 + 299.510 = 447.565$

Thus we have verified that $3 \times \text{median} = \text{mode} + 2 \times \text{mean}$ (Approx)

ACTIVITY – 5

TOPIC : Angle of Elevation

OBJECTIVE : To find the angle of elevation of the sun at a particular time on a sunny day.

PRE-REQUISITE KNOWLEDGE: knowledge of trigonometric ratios.

MATERIAL REQUIRED :

1. A metre rod
2. Measuring tape
3. Table for tangent of angles .

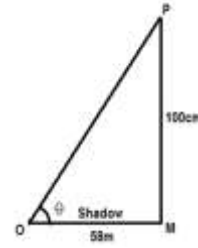

TO PERFORM THE ACTIVITY:

STEPS :

1. On the particular sunny day at the given time, put the metre rod on the level ground with one end on the ground and the other vertically upward.
2. Measure the length of the shadow of the metre rod from the beginning to the end. Let the length of the shadow be 58cm = 0.58m.
3. The length of the metre rod = 1m or 100cm.

OBSERVATION:

1. If θ be the angle of elevation of the sun at the given moment, then we have the following figure on a sheet of paper by taking a suitable scale.
2. From the right angle $\triangle OMP$ drawn in figure, we have

$$\tan \theta = \frac{MP}{OM} = \frac{100}{58} = 1.724(\text{approx})$$

$$\tan \theta = \sqrt{3} (\text{approx.})$$

$$\text{i.e. } \tan \theta = \tan 60^\circ$$

$$\theta = 60^\circ$$

Hence, the required angle of elevation of the sun is 60° . For better result, we can take the help of the table of tangent of angles.

ACTIVITY – 6

TOPIC - Probability of events of a random experiment.

STATEMENT: For an event E of a random experiment, $P(\text{not } E) = 1 - P(E)$.

OBJECTIVE: To verify the above statement by tossing three coins of different denominations simultaneously for head and tail. Event E happens if we get at least two heads and the event not-E happens if we do not get two or more than two heads.

PRE-REQUISITE KNOWLEDGE:

1. Probability of an event : $\frac{\text{Number of outcome which favour the happening of the event } E}{\text{Total number of outcome}}$
2. Event not-E happens when the outcome is not favourable for the event E to happen.

TO PERFORM THE ACTIVITY:

STEPS:

1. Take three fair coins of different denominations and toss these coins simultaneously.
2. We imagine about the possible outcomes as below.

HHH, HHT, HTH, THH, HTT, TTH, TTT

i.e. there can be 8 possible outcomes

favourable outcomes to the event E are

HHH, HHT, HTH, THH

Then $P(E) = \frac{4}{8} = \frac{1}{2}$

Now, favourable outcomes to the event not-E are HTT, THT, TTH, TTT

Then $P(\text{not-E}) = 1 - \frac{1}{2} = 1 - P(E)$

3. Repeating above random experiment, we record the observation of 20 trials as below:

Number of Heads:	0	1	2	3
------------------	---	---	---	---

Number of times out of 20 trials :	4	7	5	4
------------------------------------	---	---	---	---

4. From table in step 3, we observe that for 2 heads or for 3 heads, the event E happens i.e. there are $5+4=9$ chances out of 20 which favour E

Thus, we have $P(E) = \frac{9}{20}$

Also we observe that for 0 head or for 1 head the event not-E happens. There are $4+7=11$ chances out of 20 which favour not-E.

So, $P(\text{not-E}) = \frac{11}{20} = 1 - \frac{9}{20} = 1 - P(E)$.

QUIZ

(REAL NUMBERS)

Answer the following questions

1. What is a lemma?
2. State Euclid's Division Lemma?
3. What does HCF stand for?
4. Give the full form of LCM.
5. State Euclid's division algorithm.

ORAL TEST

(REAL NUMBERS)

Answer the following questions:

1. Euclid's division algorithm is a technique to compute the _____ of two given positive integers.
2. $HCF(124, 24)$ is _____.
3. "Every composite number can be expressed(factorised) as a product of primes, and this factorisation is unique, apart from the order in which the prime factors occurs". The above statement is called _____.
4. For any two positive integers a and b,
 $a \times b = HCF(a, b) \times$ _____
5. If a number cannot be written in the form p/q , where p and q are integers and $q \neq 0$, then it is called _____.

QUIZ

(POLYNOMIALS)

Answer the following questions:

1. What is a quadratic polynomial?
2. What is the degree of a quadratic polynomial?
3. What are the zeros of a polynomial?
4. What is the shape of curve of a quadratic polynomial graph?
5. State remainder theorem.

ORAL TEST

1. If $P(x)$ is a polynomial in x, the highest power of x in $P(x)$ is called the _____ of the polynomial $P(x)$.
2. A polynomial of degree 2 is called a _____.
3. The linear polynomial $ax + b$, $a \neq 0$, has exactly one zero, namely, the x-coordinate of the point where the graph of $y = ax + b$ intersects the _____.
4. A polynomial $P(x)$ of degree n has atmost _____ zeroes.
5. The sum and the product of the zeroes of a quadratic polynomial $x^2 + 7x + 10$ is ____ and _____.

QUIZ

(Pair of linear equations in two variables)

Answer the following questions:

1. What is a pair of linear equations in two variables?
2. Give the general form of a pair of linear equation?
3. What are the methods of solving a pair of linear equation in two variables?
4. What is the condition for inconsistent solution?
5. What is the shape of curve in graph of a linear equation?

Oral Test

1. Every solution (x, y) of a linear equation in two variables, $ax+by+c=0$ corresponds to a ____ on the line representing the equation, and vice versa.
2. If the pair of linear equations in two variables have only one common point on both the lines, then we have a _____ solution.
3. A pair of equations which has no solution is called a/an _____ pair of linear equations.
4. Half the perimeter of a rectangular garden, whose length is 4 m more than its width is 36 m. The dimension of the garden are _____ and _____.

5. A pair of linear equations in two variables can be represented and solved by the graphical method and _____ method.

QUIZ

(Triangles)

1. What is SAS similarity criterion?
2. What is the relationship between congruency and similarity of figures?
3. What is the criteria for the similarity of two triangles?
4. For what types of triangles is Pythagoras theorem applicable?
5. What is the another name of Basic Proportionality Theorem?

ORAL TEST

1. All _____ triangles are similar (equilateral/ isosceles/ Scalene)
2. The longest side of a right angled triangle is called _____.
3. In a _____ the square of the hypotenuse is equal to the sum of squares of the other two sides.
4. In the given figure, if $DE \parallel BC$, then the value of x is _____

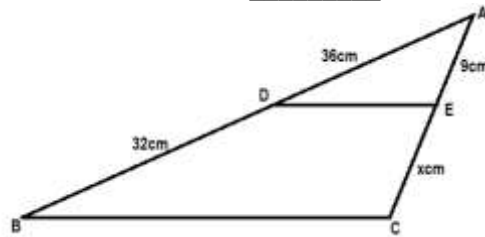

5. State whether the following quadrilateral are similar or not.

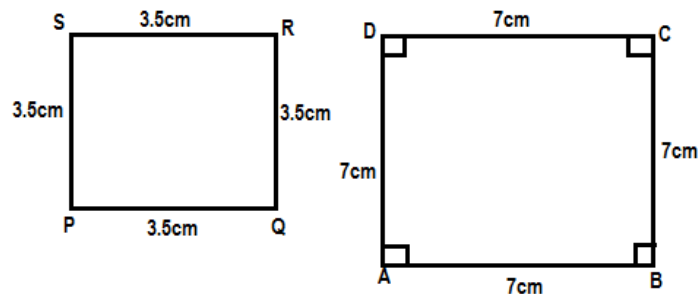

QUIZ

(Introduction to Trigonometry)

1. What is trigonometry?
2. What are trigonometric ratios of an acute angle in a right triangle?
3. From the figure find the value of $\cos A$.

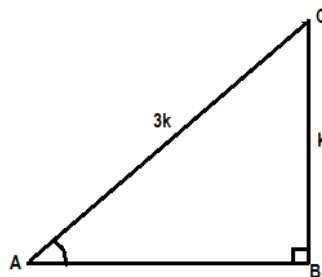

4. Write the trigonometric ratios of 60° .
5. Evaluate $\tan 70^\circ / \cot 20^\circ$.

ORAL TEST

1. In a right triangle ABC, right angles at B, $\sin A =$ _____.
2. $\sec(90^\circ - A) =$ _____
3. $\sec^2 A -$ _____ $= 1$, for $0^\circ \leq A \leq 90^\circ$.
4. If $\cot \theta = 7/8$, then $(1 + \sin \theta)(1 - \sin \theta) / (1 + \cos \theta)(1 - \cos \theta)$
5. $(1 - \tan^2 45^\circ) / (1 + \tan^2 45^\circ) =$ _____

QUIZ

(STATISTICS)

1. Name the measures of central tendency.
2. What is cumulative frequency?
3. How will you represent the cumulative frequency distribution graphically?
4. How will you find the median of a grouped data graphically with the help of one ogive?
5. How will you find the median of a grouped data graphically with the help of both ogives (i.e. of the less than type and of more than type)?

ORAL TEST

1. _____ is the sum of the values of all the observations divided by the total number of observations.
2. Class mark = _____ / 2.
3. The formula for finding the mean using the step deviation method is _____.
4. The formula for finding the mode in a grouped frequency distribution is _____.
5. The formula for finding the median of grouped data is _____.

FORMATIVE ASSESSMENT

QUIZ

1. Define the fundamental theorem of arithmetic.
2. Define euclid's division lemma.
3. What is a quadratic polynomial.
4. What is the relationship between zeros and coefficients of a quadratic polynomial.
5. Give the condition for a pair of linear equations to be inconsistent.

ORAL TEST

1. For any two positive integers a and b, $HCF(a,b) \times LCM(a, b) =$ _____
2. $5 - \sqrt{3}$ is a/an _____ number.
3. A polynomial of degree 3 is called a _____ polynomial.
4. A quadratic polynomial having the sum and product of its zeroes respectively 5 and 6 is _____.
5. All _____ triangles are similar. (equilateral/isosceles/scalene).

QUIZ

QUADRATIC EQUATION

1. What is a quadratic equation?
2. How many roots can a quadratic equation have?
3. Give the formula for finding the roots of $ax^2 + bx + c = 0$ ($a \neq 0$)
4. Give the nature of roots of the equation $ax^2 + bx + c = 0$ ($a \neq 0$)
5. Find the nature of the roots of the equation $3x^2 - 2x + 1/3 = 0$

ORAL TEST

1. A real number α is said to be a root of the quadratic equation $ax^2 + bx + c = 0$, if $a\alpha^2 + b\alpha + c =$ _____.
2. A quadratic equation $ax^2 + bx + c = 0$ has two roots, if $b^2 - 4ac > 0$.
3. The quadratic equation $3x^2 - 4\sqrt{3}x + 4 = 0$ has two _____ roots.
4. The roots of a quadratic equation $2x^2 - 7x + 3 = 0$ are _____ and _____.
5. Two numbers whose sum is 27 and product is 182 are _____ and _____.

QUIZ

(ARITHMETIC PROGRESSIONS)

1. What is an A.P.?
2. What is meant by common difference in an A.P. ?
3. What is the formula for the nth term of an A.P.?

4. What is the formula for the sum of first n terms of an A.P. ?
5. What is the formula for the sum of first n natural numbers?

ORAL TEST

1. The common difference of a sequence of multiples of 7 is _____.
2. The difference of consecutive terms in an A.P. is always _____.
3. The sum of first 20 natural numbers is _____.
4. The sum of first eight odd natural numbers is _____.
5. The sum of first ten even natural numbers is _____.

QUIZ

(Coordinate geometry)

1. What is abscissa?
2. What is ordinate?
3. What is distance formula?
4. What is the distance of a point $p(x,y)$ from origin?
5. Give the section formula.

ORAL TEST

1. If the area of a triangle is 0 square units, then its vertices are _____.
2. The area of a triangle whose vertices are $(1, -1)$, $(-4, 6)$ and $(-3, -5)$ is _____ square units.
3. The distance between the points $(-5, 7)$ and $(-1, 3)$ is _____ units.
4. _____ has been developed as an algebraic toll for studying geometry of figures.
5. The distance between the points (a,b) and $(-a, -b)$ is _____ units.

QUIZ

(Some applications of trigonometry or heights and distance)

1. Why trigonometry was invented? Give its uses.
2. What is the line of sight?
3. What is the angle of elevation?
4. What is the angle of depression?
5. What is a theodolite?

ORAL TEST

1. The other name of clinometer is _____.
2. If height of clinometer is 1 m, distance between object and clinometer is 40m and angle of elevation of object is 45° , then the height of object is _____.
3. A tower stands vertically on the ground. From the point on the ground, which is 25m away from the foot of the tower, the angle of elevation of the top of the tower is found to be 60° . The height of the tower is _____.
4. The angles of elevation of the top of a tower from two points at distances a and b from the base and on the same straight line with it are complementary. The height of the tower is _____.
5. A ladder 15m long just reaches the top of a vertical wall. If the ladder makes an angle of 60° with the wall, then the height of the wall is _____.

QUIZ

(CIRCLES)

1. Define tangent to a circle.
2. How many tangent(s) is/are there at a point of circle?
3. How many tangent can be drawn to a circle from a point outside the circle?
4. Define length of a tangent.
5. What is the relation between the lengths of tangents drawn from an external point to a circle?

ORAL TEST

1. A tangent to a circle intersects it in _____ point(s).
2. A line intersecting a circle in two points is called a _____.
3. A circle can have _____ parallel tangents at the most.
4. The common point of a tangent to a circle and the circle is called _____.
5. The tangent at any point of a circle is _____ to the radius through the point of contact.

QUIZ

(Constructions)

1. What is scale factor?
2. How will you draw a tangent at a point of a circle?
3. How will you locate the centre of a circle, if it is not given?
4. How many tangents can be drawn from a point outside the circle?
5. Is it possible to draw a tangent from a point inside a circle?

ORAL TEST

1. To divide a line segment AB in the ratio $m:n$ (m, n are positive integers), draw a ray AX so that $\angle BAX$ is an acute angle and then mark point on ray AX at equal distances such that the minimum number of these points is _____.
2. To draw a pair of tangents to a circle which are inclined to each other at an angle of 45° , it is required to draw tangents at the end point of those two radii of the circle, the angle between which is _____.
3. To divide a line segment AB in the ratio 4:5, a ray AX is drawn first such that $\angle BAX$ is an acute angle and then points A_1, A_2, A_3, \dots are located at equal distance on the ray AX and the point B is joined to _____.
4. To construct a triangle similar to a given $\triangle ABC$ with its sides $\frac{3}{5}$ of the corresponding sides of $\triangle ABC$, first draw a ray BX such that $\angle CBX$ is an acute angle and X lies on the opposite side of A with respect to BC. To locate points B_1, B_2, B_3, \dots on BX at equal distances and next step is to join _____ to _____.
5. State 'True' or 'False'
 - a. By geometrical construction, it is possible to divide a line segment in the ratio $3+\sqrt{5} : 3-\sqrt{5}$.
 - b. A pair of tangents can be drawn from a point P to a circle of radius 4.5 cm situated at a distance of 4 cm from the centre.
 - c. By geometrical construction, it is possible to divide a line segment in the ratio $\sqrt{5} : 1/\sqrt{5}$.
 - d. A pair of tangents can be constructed to a circle inclined at an angle of 175° .
 - e. From a point P outside the circle we can draw only one tangent.
 - f. We cannot locate the centre of a circle if it is not given.

QUIZ

(AREAS RELATED TO CIRCLES)

1. What is circumference of a circle? Give its formula.
2. Name the great Indian mathematician who gave an approximate value of π .
3. Give the formula for the area of a circle of radius r cm.
4. Give the formula for area of a sector of a circle having radius r and measuring an angle θ at the centre.
5. How will you find the area of a segment of a circle?

ORAL TEST

1. If the area of a circle is 154 cm^2 , then its perimeter is _____.
2. Area of the largest triangle that can be inscribed in a semicircle of radius r is _____.
3. The diameter of a circle whose area is equal to the sum of the areas of the two circles of radii 24 cm and 7 cm is _____.
4. If the areas of two circles are equal, then their circumferences are _____.
5. The circles which have the same centre are called _____ circles.

QUIZ

(SURFACE AREAS AND VOLUMES)

1. A cone of height 24cm and radius of base 6cm is made up of modeling clay. A child reshapes it in the form of a sphere. Find the radius of the sphere.
2. A shuttle cork used for playing badminton has the shape of the combination of which basic solids?
3. What is a frustum of a right circular cone?
4. Does a frustum has two circular ends with equal radii?
5. Give the formula for the volume of the frustum of a cone.

ORAL TEST

1. A plumbline(sahul) shown in the figure is the combination of a _____ and a cone.

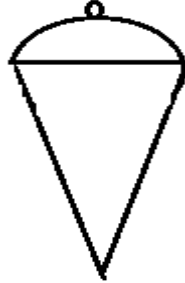

2. If the radii of the circular ends of a conical bucket which is 45cm high, are 28cm and 7cm then the capacity of the bucket is _____ cm^3 .
3. The volume of the solid formed by joining two basic solids will actually be the _____ of the volumes of the constituents.
4. The curved surface area of the frustum of a cone is _____, where $l = \sqrt{h^2 + (r_1 - r_2)^2}$
5. If two cubes each of volumes 64cm^3 are joined end to end then the surface area of the resulting cuboid is _____.

QUIZ

(PROBABILITY)

1. Define the theoretical probability of an event E.
2. What is the probability of a sure event?
3. What is an elementary event?
4. What are complementary events?
5. One card is drawn from a well shuffled deck of 52 cards. Calculate the probability that the card will be a king.

ORAL TEST

1. The probability of an impossible event is _____.
2. The probability of an event lies between _____ and _____.
3. The sum of the probabilities of all the elementary events of an experiment is _____.
4. A die is thrown once, the probability of getting a prime number is _____.
5. Two coins are tossed simultaneously. The probability of at most one tail is _____.

PUZZLES

1. Catching Fish

If Five fishermen catch 5 fishes in 5 minutes, how long will it take fifty fishermen to catch fifty fish?

2. Look at the Division

One day professor Agarwal went to the blackboard and demonstrated to his astonished class that one half of eight was equal to three! What did the professor do?

3. How Big

Can you guess how big the number : ninth power nine?

4. Counting Street Lights

On two sides of a street, there are 35 street lights, each one is at a distance of 30 metres from the other. The street lights on one side are arranged so that each lamp fills a gap between the two other street lights on the opposite. How long is the street?

5. Who covered more distance

Two friends Vijay and Ajay walk with constant speed of 100m/min. Vijay takes rest for 1 min after walking 100metres while Ajay takes rest for 3 min after walking 300 metres on a square path of side 400m. Both of them start from the same corner in opposite direction. Who covered more distance and when they meet?

6. The missing Six

Place the six numbers below into empty circles, so that both the equation are true. Use each number once and only once.

(1)	(2)	(3)	(4)	(5)	(7)
○	+	○	=	○	
○	-	○	=	○	

7. Magic Triangle

Place the numbers 4 through 9 in the circles in such a way that every side of the triangle add up to 21.

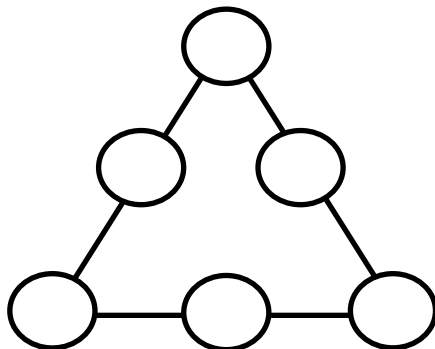

8. Add up

Here is an equilateral triangle. Add another equilateral triangle to it in such a way that you get five equilateral triangles.

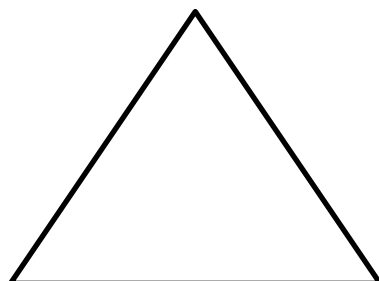

9. Magic Sticks

Just by moving one stick, make another equation.

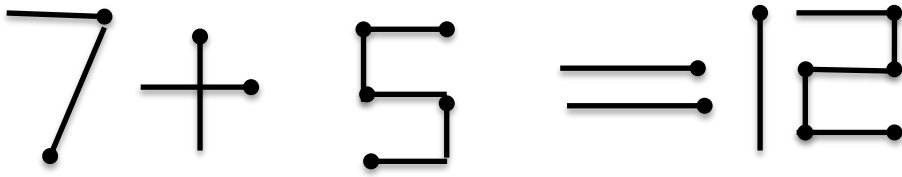

10. Identical Four

Divide the adjoining figure into four identical pieces.

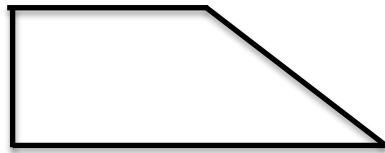

---XXX---