

Title	Size	Time	Neg	Mode	Categories	Test Date	
Grand test-1	75	180	1	Manual	Physical World and Measurements Motion in a Straight Line Laws of Motion Work, Energy and Power Thermodynamics Kinetic Theory of Gas Electric Charges and Fields Current Electricity Moving charges and magnetism Electromagnetic Induction Ray Optics and Optical Instruments Dual Nature of Matter and Radiation Atoms Electronic Devices Some Basic concepts in Chemistry States of Matter: Gases and Liquids Structure of Atom Chemical Bonding and Molecular Structure Solutions Equilibrium Chemical Kinetics Surface Chemistry p-BLOCK ELEMENTS GROUP 13(BORON FAMILY) d - and f -Block Elements Organic Chemistry: Some basic Principles and Techniques Haloalkanes and Haloarenes Alcohols, Phenols and Ethers Polymers Complex Numbers and Quadratic Equations Matrices Sequences and Series Limits and Derivatives Integrals Differential Equations Straight Lines Vectors Statistics Trigonometric Functions Mathematical Reasoning Application of Derivatives Motion in a Plane Thermal Properties of Matter Alternating Current Electrochemistry Aldehydes, Ketones and Carboxylic Acids Conic Sections Relations and Functions Inverse Trigonometric Functions Determinants Applications of the Integrals Three - dimensional Geometry P - Block Elements Probability	2020-01-01 14:00:00	2020-01-01 17:00:00

S.No	Question
	Mathematics
1	<p>If S is the set of distinct values of b for which the system of equations $x + y + z = 1$, $x + ay + z = 1$ and $ax + by + z = 0$ has no solution, then S is</p> <p>A) An infinite set B) A finite set containing 2 (or) more elements C) Singleton set D) An empty set</p> <p style="text-align: right;">Determinants</p>
2	<p>If the integers m and n are chosen at random between 1 and 100, then the probability that a number of the form $7^m + 7^n$ is divisible by 5 equals to</p> <p>A) $\frac{1}{4}$ B) $\frac{1}{7}$ C) $\frac{1}{8}$ D) $\frac{1}{49}$</p> <p style="text-align: right;">Probability</p>
3	<p>The mean and median of the following ten numbers in increasing order 10, 22, 26, 29, 34, x, 42, 67, 70, y are 42 and 35 respectively, then $\frac{y}{x}$ is equal to</p>

	A) $\frac{7}{3}$ B) $\frac{7}{2}$ C) $\frac{8}{3}$ D) $\frac{9}{4}$	Statistics
4	If the angles of elevation of the top of a tower from three collinear points A, B and C on a line leading to the foot of the tower are 30° , 45° and 60° respectively, then the ratio AB : BC is	
	A) $\sqrt{3} : 1$ B) $\sqrt{3} : \sqrt{2}$ C) $1 : \sqrt{3}$ D) $2 : 3$	Trigonometric Functions
5	The boolean expression $\sim(p \vee q) \vee (\sim p \wedge q)$ is equivalent to	
	A) $\sim p$ B) p C) q D) $\sim q$	Mathematical Reasoning
6	If the plane $2x - y + 2z + 3 = 0$ has the distances $\frac{1}{3}$ and $\frac{2}{3}$ units from the planes $4x - 2y + 4z + \lambda = 0$ and $2x - y + 2z + \mu = 0$ respectively, then the maximum value of $\lambda + \mu$ is equal to	
	A) 13 B) 15 C) 5 D) 9	Three - dimensional Geometry
7	A tetrahedron has the vertices P(1, 2, 1) Q(2, 1, 3) R(-1, 1, 2) and O(0, 0, 0). The angle between the faces OPQ and PQR is	
	A) $\cos^{-1}\left(\frac{7}{31}\right)$ B) $\cos^{-1}\left(\frac{9}{35}\right)$ C) $\cos^{-1}\left(\frac{19}{35}\right)$ D) $\cos^{-1}\left(\frac{17}{31}\right)$	Vectors
8	The value of x for which $\sin[\cot^{-1}(1+x)] = \cos(\tan^{-1}x)$ is equal to	
	A) $\frac{1}{2}$ B) 1 C) 0 D) $\frac{-1}{2}$	Inverse Trigonometric Functions
9	The equation $\frac{x^2}{1-r} - \frac{y^2}{1+r} = 1, r < 1$, represents	
	A) An ellipse B) A hyperbola C) A circle D) None of these	Conic Sections
10	Axis of the parabola is $y = x$ and the vertex and focus are at a distance of $\sqrt{2}$ and $2\sqrt{2}$ respectively from the origin. Then the equation of the parabola is	
	A) $(x - y)^2 = 8(x + y - 2)$ B) $(x + y)^2 = 2(x + y - 2)$ C) $(x - y)^2 = 4(x + y - 2)$ D) $(x + y)^2 = 2(x - y + 2)$	Conic Sections
11	The circle passing through the point (-1, 0) and touching the Y-axis at (0, 2) also passes through the point	
	A) $\left(\frac{-3}{2}, 0\right)$ B) $\left(\frac{-5}{2}, 2\right)$ C) $\left(\frac{-3}{2}, \frac{5}{2}\right)$ D) (-4, 0)	Conic Sections

12	The shortest distance between the point $\left(\frac{3}{2}, 0\right)$ and the curve $y = \sqrt{x}$ ($x > 0$) is	Straight Lines
A) $\frac{3}{2}$ B) $\frac{5}{4}$ C) $\frac{\sqrt{3}}{2}$ D) $\frac{\sqrt{5}}{2}$		
13	If $x dy = y (dx + y dy)$, $y(1) = 1$ and $y(x) > 0$. Then $y(-3)$ is equal to	Differential Equations
A) 3 B) 2 C) 1 D) 0		
14	If the line $x = \alpha$ divides the area of the region $R = \{(x, y) \in \mathbb{R}^2 / x^3 \leq y \leq x, 0 \leq x \leq 1\}$ into two equal parts, then	Applications of the Integrals
A) $2\alpha^4 + 4\alpha^2 + 1 = 0$ B) $\alpha^4 + 4\alpha^2 - 1 = 0$ C) $\frac{-1}{2} < \alpha < 0$ D) $\alpha^2 = 1 - \frac{1}{\sqrt{2}}$		
15	The integral $\int_{\pi/6}^{\pi/3} \frac{1}{1 + \sqrt{\tan x}} dx$ is equal to	Integrals
A) $\frac{\pi}{12}$ B) $\frac{\pi}{3}$ C) $\frac{\pi}{6}$ D) $\frac{2\pi}{3}$		
16	If 20 metre of wire is available for fencing off a flower-bed in the form of a circular sector then the maximum area (in sq.metre) of flower bed is	Application of Derivatives
A) 12.5 B) 10 C) 25 D) 30		
17	Let $P(x)$ be a polynomial of degree 4 having extremum at $x = 1, 2$ and $\lim_{x \rightarrow 0} \left[1 + \frac{P(x)}{x^2}\right] = 2$. Then, the value of $P(2)$ is	Limits and Derivatives
A) 1 B) 2 C) 0 D) -1		
18	For $x \in \left(0, \frac{3}{2}\right)$ let $f(x) = \sqrt{x}$, $g(x) = \tan x$ and $h(x) = \frac{1 - x^2}{1 + x^2}$ and if $\Phi(x) = ((h \circ f) \circ g)(x)$ then $\phi\left(\frac{\pi}{3}\right)$ is equal to	Relations and Functions
A) $\tan \frac{\pi}{12}$ B) $\tan \left(\frac{11\pi}{12}\right)$ C) $\tan \frac{7\pi}{12}$ D) $\tan \frac{5\pi}{12}$		
19	The minimum number of times a fair coin needs to be tossed, so that the probability of getting atleast two heads is atleast 0.96 is	Probability
A) 7 B) 8 C) 6 D) 9		

20	If the sum of n terms of an AP is cn^2 , then the sum of squares of these n terms is	
	A) $\frac{n(4n^2 - 1)c^2}{6}$ B) $\frac{n(4n^2 + 1)c^2}{3}$ C) $\frac{n(4n^2 - 1)c^2}{3}$ D) $\frac{n(4n^2 + 1)c^2}{6}$	Sequences and Series
21	The coefficient of x^{11} in the expansion of $(1 + x^2)^4 (1 + x^3)^7 (1 + x^4)^{12}$ is _____	Trigonometric Functions
22	If a, b, c are the lengths of the sides opposite to vertices A, B, C of ΔABC and $a = 6, b = 10$ and the area of triangle is $15\sqrt{3}$. $\angle ACB$ is obtuse angle and r is the radius of in circle of triangle, then r is equal to _____	Trigonometric Functions
23	The area of the quadrilateral formed by the tangents at the end point of the latus rectum to the ellipse $\frac{x^2}{9} + \frac{y^2}{5} = 1$ is _____	Conic Sections
24	If α and β are the roots of the equation $375x^2 - 25x - 2 = 0$, then $\lim_{n \rightarrow \infty} \sum_{r=1}^n \alpha^r + \lim_{n \rightarrow \infty} \sum_{r=1}^n \beta^r$ is equal to _____	Complex Numbers and Quadratic Equations
25	Let A and B be two invertible matrices of order 3×3 . If $\det(ABA^T) = 8$ and $\det(AB^{-1}) = 8$, then $\det(BA^{-1}B^T)$ is equal to _____	Matrices
Physics		
26	Time has a direction, it can never be negative still then it is a scalar and not a vector quantity. Which statement is the correct explanation for the time not being to be vector?	
	A) It is not obeying law of parallelogram addition B) It has unique direction C) Both (a) and (b) D) None of the above	Motion in a Plane
27	Two photons A and B are moving towards each other with a speed c and $3c/2$ respectively. Find the speed of A with respect to B .	
	A) $5c/2$ B) $c/2$ C) $3c/2$ D) c	Dual Nature of Matter and Radiation

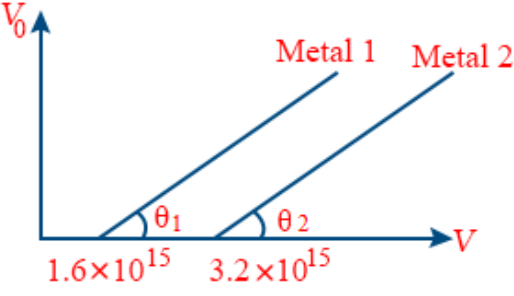
28	<p>A monkey is sitting on the top of a tree, having an apple in his hand. A person standing on the ground at a distance d from the foot of the tree, throws a stone towards the monkey directly aiming towards the apple, and at the same instant the monkey drops the apple, then</p>
	<p>A) stone will always hit the apple B) stone will hit the apple in certain circumstances C) stone and apple would have same speed when they collide D) None of the above</p> <p style="text-align: right;">Laws of Motion</p>
29	<p>The graph between stopping potential versus frequency is given for two different metals, then choose the most appropriate statement</p> 
	<p>A) $V_{01} = V_{02}$ and $\theta_1 = \theta_2$ B) $V_{01} > V_{02}$ and $\theta_1 > \theta_2$ C) $V_{01} < V_{02}$ and $\theta_1 < \theta_2$ D) $V_{01} < V_{02}$ and $\theta_1 = \theta_2$</p> <p style="text-align: right;">Atoms</p>
30	<p>A constant current of 2.8 A exists in a resistor. The rms current is</p>
	<p>A) 2.8 A B) about 2 A C) 1.4 A D) undefined for a direct current</p> <p style="text-align: right;">Alternating Current</p>
31	<p>A particle is moving in xy-plane, whose position vectors are given as a function of time : $x = 2.0 \text{ m} - (0.25 \text{ m/s}^2)t^2$ and $y = (1.0 \text{ m/s})t + (0.025 \text{ m/s}^3)t^3$ Find the unit vector along particle's velocity at $t = 2 \text{ s}$.</p>
	<p>A) $\frac{(\hat{i} + 2.2\hat{j})}{2.42}$ B) $\frac{(-\hat{i} + 1.3\hat{j})}{1.64}$ C) \hat{j} D) $\frac{(\hat{k} + \hat{j})}{\sqrt{2}}$</p> <p style="text-align: right;">Motion in a Plane</p>
32	<p>An electric field is applied to a semiconductor. Let the number of charge carries be n and the average drift speed be v. If the temperature is increased, then</p>
	<p>A) both n and v will increase B) n will increase but v will decrease C) v will increase but n will decrease D) both n and v will decrease</p> <p style="text-align: right;">Electronic Devices</p>
33	<p>An object is launched straight up into the air from the ground with an initial velocity of 30 m/s. The object rises to a highest point approximately 45 m above the ground in 3 s, it then falls back to the ground in 3 more second, impacting with a speed of 30 m/s. Determine the closest value of average speed and average velocity during 6 s interval.</p>

A) 0 m/s, 0 m/s **B)** 15 m/s, 0 m/s **C)** 0 m/s, 15 m/s **D)** 15 m/s, 15 m/s

Motion in a Straight Line

- 34 A very long cylindrical wire of radius R carries a current I_0 uniformly distributed across the cross-section of the wire. Calculate the magnetic flux through a rectangle that has one side of length w running down the centre of the wire and another side of length R , as shown in figure.

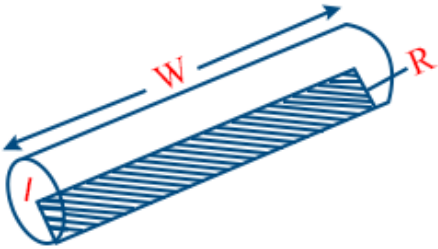

A) $\frac{\mu_0 I_0 \times wR}{4\pi}$ **B)** $\frac{\mu_0 I_0 w}{4\pi}$ **C)** $\frac{\mu_0 I_0 R^2}{4\pi w}$ **D)** None of these

Electromagnetic Induction

- 35 For a polytropic process whose equation is given by $pV^x = \text{constant}$, $x \neq 0, 1$ or γ , which is true?

A) Molar heat capacity, $C = C_v + R/(1 - x)$

B) Work done by gas when temperature changes from T_1 to T_2 is $W = \frac{nR(T_2 - T_1)}{(1 - x)}$

C) Bulk modulus, $B = xp$ **D)** All of the above

Kinetic Theory of Gas

- 36 Consider a region bounded by conical surface as shown in figure. In this region, E is in vertical upward direction. Find the flux crossing this surface.

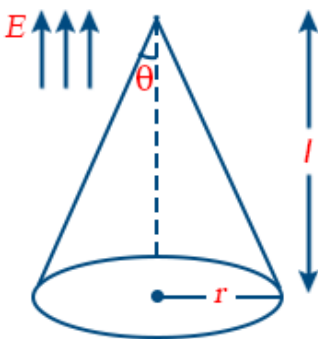

A) $\pi r^2 E$ **B)** $\pi r^2 \sin \theta \times E$ **C)** $\pi r/E \sin \theta/3$ **D)** $\pi r^2 / \cos \theta \times E/3$

Moving charges and magnetism

- 37 After falling from rest through a distance Y , a body of mass m begins to raise a body of mass M ($M > m$) that is connected to it by means of a light inextensible string passing over a fixed smooth pulley. Find the time it will take for the body of mass M to return to its original position.

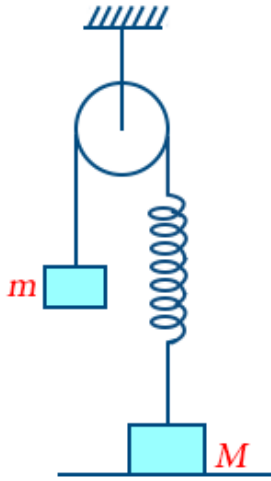

A) $\frac{2m}{(M+m)} \times \sqrt{\frac{2y}{g}}$ B) $\frac{m}{M} \sqrt{\frac{2y}{g}}$ C) $\frac{2m}{M-m} \sqrt{\frac{2y}{g}}$ D) $\frac{m}{M-m} \sqrt{\frac{2y}{g}}$

Laws of Motion

- 38 A ray of light is incident on a plane mirror, along the direction give by vector $2\hat{i} - 3\hat{j} + 4\hat{k}$. Find the unit vector along reflected ray. Take normal to mirror along the direction of vector $B = 3\hat{i} - 6\hat{j} + 2\hat{k}$

A) $\frac{-94\hat{i} + 237\hat{j} + 68\hat{k}}{49\sqrt{29}}$ B) $\frac{-94\hat{i} + 68\hat{j} - 237\hat{k}}{49\sqrt{29}}$ C) $\frac{3\hat{i} + 6\hat{j} - 2\hat{k}}{7}$ D) None of these

Ray Optics and Optical Instruments

- 39 A charged solid conductor having a cavity is shown in figure. If a charge $+q$ is placed asymmetrically within the cavity, then charge induced on outer surface of conductor would be

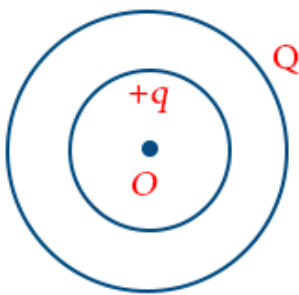

A) $-q$ B) $+q$ C) $q - Q$ D) $Q - q$

Electric Charges and Fields

- 40 An engineer is working on a new engine design. One of the moving parts contain 1.6 kg of aluminium and 0.3 kg of iron, and is designed to operate at 210°C . How much energy is dissipated as heat to raise its temperature from 20°C to 210°C ?

$S_{\text{Al}} = 910 \text{ J/kg-K}$ and $S_{\text{iron}} = 470 \text{ J/kg-K}$

A) $3.03 \times 10^5 \text{ J}$ B) $7 \times 10^5 \text{ J}$ C) $3 \times 10^6 \text{ J}$ D) $1.04 \times 10^5 \text{ J}$

Thermodynamics

- 41 When switch S is open, the reading of voltmeter is 12 V and when the switch has been closed, the reading of voltmeter is 8 V and that of ammeter is 2 A. Then, determine the emf and internal resistance of the battery. Assume the meters as ideal.

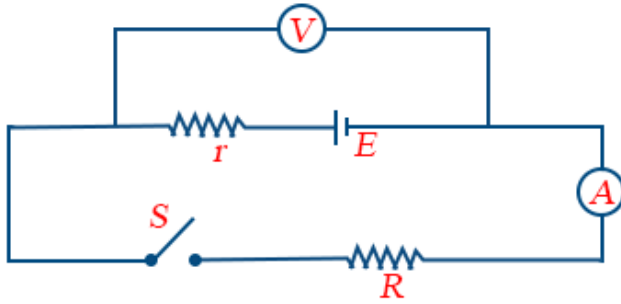

- A) 12 V, 4 Ω B) 8 V, 2 Ω C) 12 V, 2 Ω D) 8 V, 4 Ω

Current Electricity

- 42 The unit vector parallel to the resultant of the vectors $A = 4\hat{i} + 3\hat{j} + 6\hat{k}$ and $B = -\hat{i} + 3\hat{j} - 8\hat{k}$ is

- A) $\frac{1}{7}(3\hat{i} + 6\hat{j} - 2\hat{k})$ B) $\frac{1}{7}(3\hat{i} + 6\hat{j} + 2\hat{k})$ C) $\frac{1}{49}(3\hat{i} + 6\hat{j} - 2\hat{k})$ D) $\frac{1}{49}(3\hat{i} - 6\hat{j} + 2\hat{k})$

Motion in a Plane

- 43 A body of mass m is moving in a circle of radius r with a constant speed v . The force on the body is $\frac{mv^2}{r}$ and is directed towards the centre. What is the work done by this force in moving the body over half the circumference of the circle?

- A) $\frac{mv^2}{r} \times \pi r$ B) Zero C) $\frac{mv^2}{r^2}$ D) $\frac{\pi r^2}{mv^2}$



Work, Energy and Power

- 44 The length of the string of a simple pendulum is measured with a meter scale to be 92.0 cm the radius of the bob plus the hook is measured with the help of vernier caliper to be 2.17 cm. Mark out the correct statement(s).

- A) Least count of meter scale is 0.1 cm B) Least count of vernier caliper is 0.01 cm
C) Effective length of simple pendulum is 94.2 cm D) All of the above

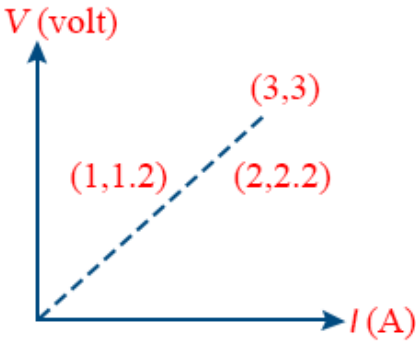
Physical World and Measurements

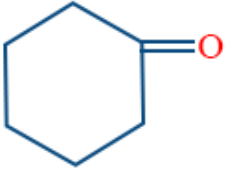
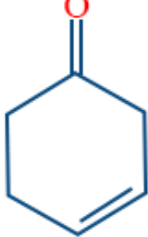
45	<p>In the measurement of resistance of a wire using Ohm's law, the plot between V and I is drawn as shown.</p>  <p>The resistance of the wire is</p>
	<p>A) 0.833 Ω B) 0.9 Ω C) 1 Ω D) None of these Current Electricity</p>
46	<p>A 3.0 kg block slides on a frictionless horizontal surface, first moving to the left at 50 m/s. It collides with a spring as it moves left, compresses the spring and is brought to rest momentarily. The body continues to be accelerated to the right by the force of the compressed spring. Finally, the body moves to the right at 40 m/s. The block remains in contact with spring for 0.020 s. _____ kg-m/s was the magnitude of the impulse of the spring on the block.</p> <p style="text-align: right;">Laws of Motion</p>
47	<p>A car has to go from station A to station B (the car will start from rest from station A and comes to halt at station B), which are at a distance of 500 m in minimum possible time. Find this minimum possible time. The car has a limiting acceleration of 7 m/s² and it can have a maximum speed of 35 m/s _____ s</p> <p style="text-align: right;">Motion in a Plane</p>
48	<p>The volume of a glass vessel is 1000 cc at 20°C. _____ cc volume of mercury should be poured into it at this temperature so that volume of remaining portion doesn't change with temperature. ($\gamma_{Hg} = 1.8 \times 10^{-4}/^{\circ}\text{C}$ and $\gamma_g = 26 \times 10^{-6}/^{\circ}\text{C}$)</p> <p style="text-align: right;">Thermal Properties of Matter</p>
49	<p>If $L = 2.331$ cm, $B = 2.1$ cm, then $L + B$ is equal to _____ cm</p> <p style="text-align: right;">Physical World and Measurements</p>
50	<p>Whenever a photon is emitted by hydrogen atom in Balmer series, it is followed by another photon in Lyman series. _____ nm wavelength does this later photon corresponds to.</p> <p style="text-align: right;">Atoms</p>
<div style="border: 1px solid black; padding: 5px; display: inline-block;">Chemistry</div>	

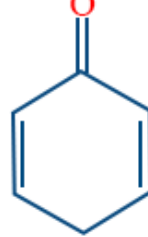
51	<p>The hybrid state of Co in high spin K_3CoF_6 complex is</p> <p>A) sp^3d^2 B) sp^3 C) d^2sp^3 D) sp^3d</p> <p style="text-align: right;">Chemical Bonding and Molecular Structure</p>
52	<p>The separation of lanthanides by ion exchange method is based on</p> <p>A) size of the ions B) oxidation state of the ions C) the solubility of their nitrates</p> <p>D) basicity of hydroxides of lanthanides</p> <p style="text-align: right;">d - and f -Block Elements</p>
53	<p>Correct equilibrium constant expression for the reaction is</p> $HC_2H_3O_2 + H_2O \rightleftharpoons H_3O^+ + C_2H_3O_2^-$ <p>A) $K_a = \frac{[C_2H_3O_2^-][H_3O^+]}{[HC_2H_3O_2]}$ B) $K_a = \frac{[C_2H_3O_2^-]}{[HC_2H_3O_2]}$ C) $K_a = \frac{[C_2H_3O_2^-][H_3O^+]}{[HC_2H_3O_2][H_2O]}$ D) $K_a = \frac{[C_2H_3O_2^-]}{[HC_2H_3O_2][H_2O]}$</p> <p style="text-align: right;">Equilibrium</p>
54	<p>Dimethyl glyoxime in a suitable solvent was refluxed for 10 min with pure pieces of nickel sheet, it will result in</p> <p>A) red precipitate B) blue precipitate C) yellow precipitate D) non precipitate</p> <p style="text-align: right;">d - and f -Block Elements</p>
55	<p>Which is correctly matched?</p> <p>A) Tincal — $Na_2B_4O_7 \cdot 10 H_2O$ B) Boric acid — HBO_2 C) Kernite — $B_3N_3H_6$</p> <p>D) Colemanite — $Ca_2B_6O_{10}$</p> <p style="text-align: right;">p-BLOCK ELEMENTS GROUP 13(BORON FAMILY)</p>
56	<p>The increasing thermal stability of the hydrides of group 16 follows the sequence</p> <p>A) H_2O, H_2S, H_2Se, H_2Te B) H_2Te, H_2Se, H_2S, H_2O C) H_2S, H_2O, H_2Se, H_2Te</p> <p>D) H_2Se, H_2S, H_2O, H_2Te</p> <p style="text-align: right;">P - Block Elements</p>
57	<p>Mark out the molecules which exhibit maximum enol content</p> <p>A)  B)  C)  D) </p> <p style="text-align: right;">Alcohols, Phenols and Ethers</p>
58	<p>Mark out of the most unlike form of polymerisation of $CH_2 = CH - CH = CH_2$</p>

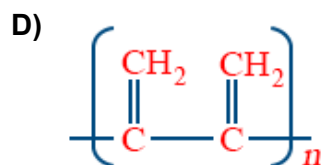
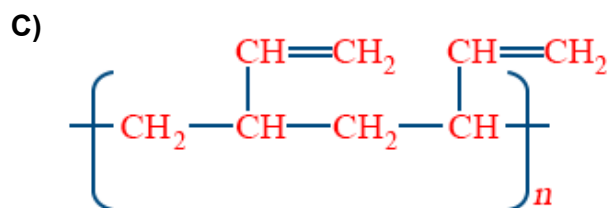
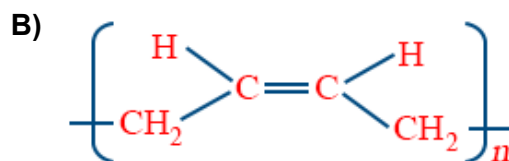
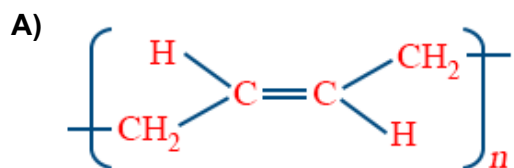

Polymers

59 $R_3\overset{\oplus}{N}-CH=CH_2 \xrightarrow{HBr}$ Product
Predominant product is

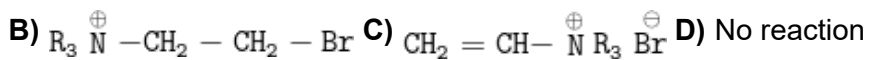
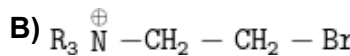
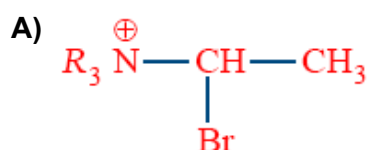

D) No reaction

Organic Chemistry: Some basic Principles and Techniques

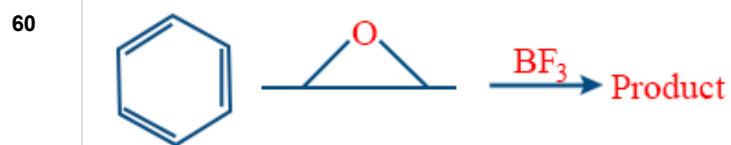

The product is

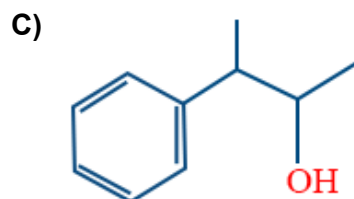
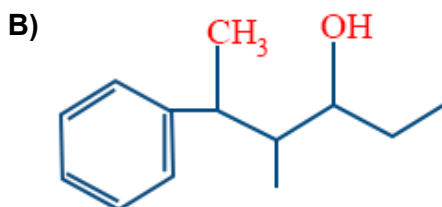
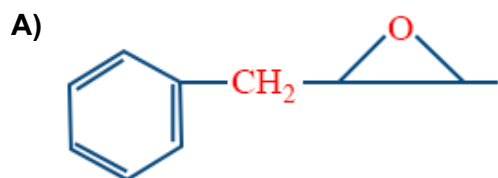

D) None of these

Haloalkanes and Haloarenes

61 The wavelength of spectral line for an electron transition is inversely related to

- A)** the number of electrons undergoing transition **B)** the nuclear charge of the atom
C) the difference in the energy levels involved in the transition
D) the velocity of electron undergoing transition

Structure of Atom

62 Correct order of decreasing thermal stability is as

- A)** $\text{NH}_3 > \text{PH}_3 > \text{AsH}_3 > \text{SbH}_3$ **B)** $\text{PH}_3 > \text{NH}_3 > \text{AsH}_3 > \text{SbH}_3$ **C)** $\text{AsH}_3 > \text{PH}_3 > \text{NH}_3 > \text{SbH}_3$
D) $\text{SbH}_3 > \text{AsH}_3 > \text{PH}_3 > \text{NH}_3$

P - Block Elements

63 This graph expresses the various steps of the system containing 1 mole of gas. Which type of process, system has when it moves from C to A?

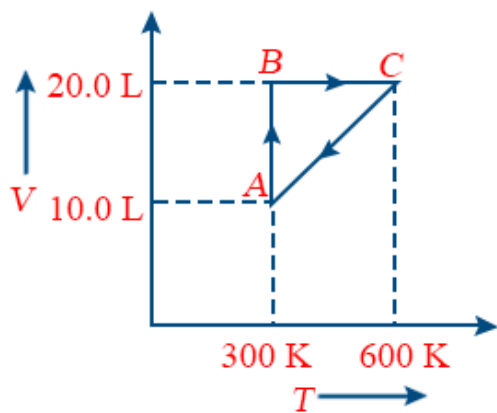

- A)** Isochoric **B)** Isobaric **C)** Isothermal **D)** Cyclic

Surface Chemistry

64 Of the following 0.10 m aqueous solution, which one will exhibit the largest freezing point depression?

- A)** KCl **B)** $\text{C}_6\text{H}_{12}\text{O}_6$ **C)** K_2SO_4 **D)** $\text{Al}_2(\text{SO}_4)_3$

Solutions

65 E° for the cell $\text{Zn}|\text{Zn}^{2+}(\text{aq})||\text{Cu}^{2+}(\text{aq})|\text{Cu}$ is 1.10V at 25°C , the equilibrium constant for the reaction $\text{Zn} + \text{Cu}^{2+}(\text{aq}) \rightleftharpoons \text{Cu} + \text{Zn}^{2+}(\text{aq})$ is of the order of

- A)** 10^{-28} **B)** 10^{-37} **C)** 10^{+18} **D)** 10^{+17}

Electrochemistry

66 In the given reaction, X is

$$\text{CH}_3\text{CHO} + \text{CH}_2(\text{COOH})_2 \xrightarrow[\text{heat}]{\text{Pyridine}} \text{X}$$

- A)** CH_3COOH **B)** $\text{C}_2\text{H}_5\text{COOH}$ **C)** $\text{CH}_3\text{CH}=\text{CH}\cdot\text{COOH}$ **D)** $\text{HOOC}\cdot\text{CH}=\text{CH}\cdot\text{COOH}$

Aldehydes, Ketones and Carboxylic Acids

67 In two H atoms A and B, the electrons move around the nucleus in circular orbits of radius r and $4r$, respectively. The ratio of the times taken by them to complete one revolution is

A) 1 : 4 B) 1 : 2 C) 1 : 8 D) 2 : 1

Structure of Atom

68 If NaCl is doped with 10^{-3} mol % SrCl₂, then what is the concentration of cation vacancies?A) $6.02 \times 10^{18} \text{ mol}^{-1}$ B) $6.02 \times 10^{19} \text{ mol}^{-1}$ C) $6.02 \times 10^{23} \text{ mol}^{-1}$ D) $6.02 \times 10^{26} \text{ mol}^{-1}$ Chemical Kinetics

69 Mark out the wrong statement about van der Waals' constant 'a'.

A) 'a' reflects magnitude of intermolecular forces B) Lower the value of 'a', greater the attractive force
C) Higher the value of 'a', higher the deviation from ideal gas D) Its unit is $\text{atm L}^2\text{mol}^{-2}$

States of Matter: Gases and Liquids

70

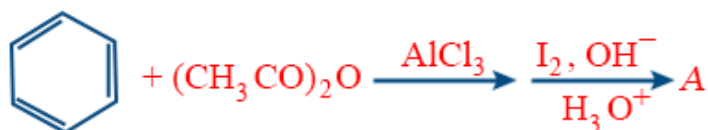

A is predominantly

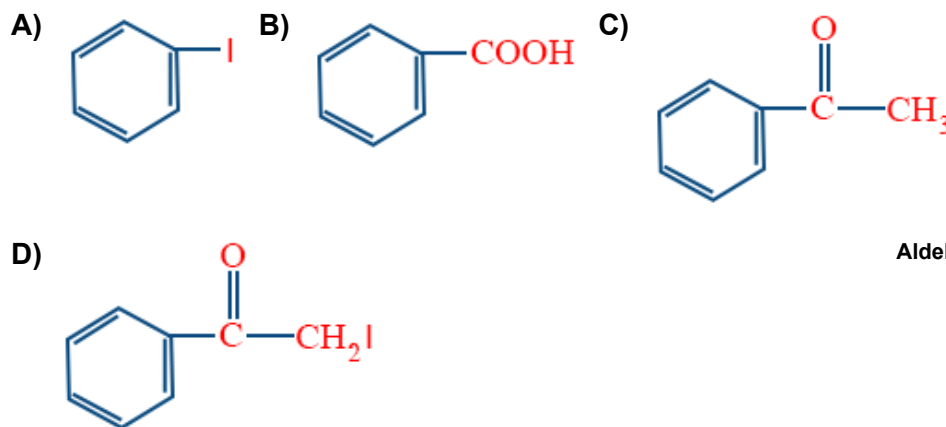

Aldehydes, Ketones and Carboxylic Acids

71 1.25 g of an impure metal was dissolved in dilute HNO₃ and the solution so formed on treatment with BaCl₂ solution precipitated 1.33 g of dry chloride of the metal. The percentage purity of metal, if equivalent weight of metal is 108, is _____%

Some Basic concepts in Chemistry

72 Mark out the enthalpy of formation of carbon monoxide (CO):

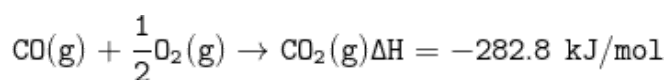

Chemical Bonding and Molecular Structure

73	In gaseous reactions important for the understanding of the upper atmosphere, H_2O and O react bimolecularly to form two OH radicals. ΔH for this reaction is 72 kJ at 500K and E_a is 77 kJ/mol. The E_a for the bimolecular recombination of two OH radicals to form H_2O and O is _____ kJ/mol
States of Matter: Gases and Liquids	
74	10 g concentrated solution of CuSO_4 is electrolysed passing 0.01 faraday of electricity. The volume of oxygen liberated at anode at STP is _____ L
Electrochemistry	
75	Under isothermal condition, a gas at 300 K expands from 0.1 L to 0.25 L against a constant external pressure of 2 bar. The work done by the gas is _____ J (Given that 1 L bar = 100 J)
Surface Chemistry	

Key											
1) C	2) A	3) A	4) A	5) A	6) A	7) C	8) D	9) B	10) A	11) D	12) D
13) A	14) D	15) A	16) C	17) C	18) B	19) B	20) C	21) 1113	22) 1.73	23) 27	24) 0.08
25) 0.06	26) C	27) D	28) B	29) D	30) A	31) B	32) B	33) B	34) B	35) D	36) A
37) C	38) A	39) B	40) A	41) C	42) A	43) B	44) D	45) C	46) 270	47) 19.28	48) 144.5
49) 4.4	50) 122	51) A	52) A	53) A	54) A	55) A	56) A	57) C	58) D	59) B	60) C
61) D	62) A	63) B	64) D	65) D	66) C	67) C	68) A	69) B	70) B	71) 80	72) 110.5
73) 5	74) 0.056	75) -30									