



Creo Elements/Direct Drafting User's Guide: Classic User Interface

Creo Elements/Direct Drafting 20.1

Copyright © 2019 PTC Inc. and/or Its Subsidiary Companies. All Rights Reserved.

User and training guides and related documentation from PTC Inc. and its subsidiary companies (collectively "PTC") are subject to the copyright laws of the United States and other countries and are provided under a license agreement that restricts copying, disclosure, and use of such documentation. PTC hereby grants to the licensed software user the right to make copies in printed form of this documentation if provided on software media, but only for internal/personal use and in accordance with the license agreement under which the applicable software is licensed. Any copy made shall include the PTC copyright notice and any other proprietary notice provided by PTC. Training materials may not be copied without the express written consent of PTC. This documentation may not be disclosed, transferred, modified, or reduced to any form, including electronic media, or transmitted or made publicly available by any means without the prior written consent of PTC and no authorization is granted to make copies for such purposes. Information described herein is furnished for general information only, is subject to change without notice, and should not be construed as a warranty or commitment by PTC. PTC assumes no responsibility or liability for any errors or inaccuracies that may appear in this document.

The software described in this document is provided under written license agreement, contains valuable trade secrets and proprietary information, and is protected by the copyright laws of the United States and other countries. It may not be copied or distributed in any form or medium, disclosed to third parties, or used in any manner not provided for in the software licenses agreement except with written prior approval from PTC.

UNAUTHORIZED USE OF SOFTWARE OR ITS DOCUMENTATION CAN RESULT IN CIVIL DAMAGES AND CRIMINAL PROSECUTION.

PTC regards software piracy as the crime it is, and we view offenders accordingly. We do not tolerate the piracy of PTC software products, and we pursue (both civilly and criminally) those who do so using all legal means available, including public and private surveillance resources. As part of these efforts, PTC uses data monitoring and scouring technologies to obtain and transmit data on users of illegal copies of our software. This data collection is not performed on users of legally licensed software from PTC and its authorized distributors. If you are using an illegal copy of our software and do not consent to the collection and transmission of such data (including to the United States), cease using the illegal version, and contact PTC to obtain a legally licensed copy.

Important Copyright, Trademark, Patent, and Licensing Information: See the About Box, or copyright notice, of your PTC software.

UNITED STATES GOVERNMENT RIGHTS

PTC software products and software documentation are "commercial items" as that term is defined at 48 C.F.R. 2.101. Pursuant to Federal Acquisition Regulation (FAR) 12.212 (a)-(b) (Computer Software) (MAY 2014) for civilian agencies or the Defense Federal Acquisition Regulation Supplement (DFARS) at 227.7202-1(a) (Policy) and 227.7202-3 (a) (Rights in commercial computer software or commercial computer software documentation) (FEB 2014) for the Department of Defense, PTC software products and software documentation are provided to the U.S. Government under the PTC commercial license agreement. Use, duplication or disclosure by the U.S. Government is subject solely to the terms and conditions set forth in the applicable PTC software license agreement.

PTC Inc., 140 Kendrick Street, Needham, MA 02494 USA

Contents

Preface.....	10
Getting Started with Creo Elements/Direct Drafting	17
The Creo Elements/Direct Drafting User Interface	18
Basic Working Methods	20
What are Viewports?	23
Positioning Menus.....	24
How to Delete Elements	24
How to Store a Workfile	25
Autosave.....	25
Getting Help	25
Switching Languages	26
Switching Between Flat and Raised Menu Buttons	26
Switching the Beeper On or Off	27
Further Reading.....	27
Preparing the Drawing Environment.....	28
Editing the Creo Elements/Direct Drafting Environment.....	29
Saving the Creo Elements/Direct Drafting Environment to a File	30
The Creo Elements/Direct Drafting Environment Listing	31
Setting Linear and Angular Units	31
Loading a Drawing Frame.....	32
Setting the Drawing Scale.....	33
Switching Copilot Functionality On and Off.....	33
Further Information	34
Commonly Used Commands	35
Deleting Elements.....	36
Selecting Drawing Elements	38
Confirming Commands.....	48
Undoing Commands	48
Ending a Command	48
Canceling Commands	48
Getting Help	48
Changing the Drawing Environment and Making Measurements	50
Changing the Linetype.....	51
Changing Pensize and Linesize	54
Changing Color.....	56
Changing the Catch Mode	62
Measuring Distances.....	63
Using the Calculator	69

Using the Ruler/Grid.....	73
Selecting What is Displayed on Your Screen	76
Viewing a Drawing	78
Using Viewports to Display Several Views.....	88
Creating an Edit Port	91
Using Properties to Change Elements and Text.....	92
Using Creo Elements/Direct Drafting's Copilot Functionality	94
Introduction	95
Setting the Cursor Delay-Time	97
Setting Snap Values.....	97
Working with Geometry	97
Offsetting Elements.....	99
Example: Slotted Plate	100
Drawing Methods.....	104
Drawing Construction Geometry	105
Drawing Construction Lines	105
Drawing Construction Circles	108
Drawing a Lever Using Construction Geometry	110
Using the Line Drawing Set.....	119
Creating Points	120
Using Overdraw	120
Drawing Lines.....	121
Drawing Circles	124
Drawing Arcs	126
Creating a Centerline	129
Creating Symmetric Elements.....	130
Indicating the Projected Reference Point	131
Creating a Reference Line	132
Splitting Elements	133
Merging Elements	134
Drawing Fillets	135
Drawing Chamfers	135
Keeping Corners.....	136
Creating a Polyline.....	137
Drawing Ellipses	138
Drawing Splines.....	142
Drawing Parallel Contours	158
Modifying a Drawing	160
Modifying Using Selection.....	162
Moving Elements	162
Rotating Drawings.....	164
Mirroring Drawings.....	165
Making Elements Larger or Smaller.....	167
Drawing Similar Elements.....	168
Creating a Parallel Perspective (Oblique) View.....	168
Stretching a Drawing	170

Drawing an Isometric View.....	171
Trimming Elements	172
Creating a Contour.....	174
Cleaning a Drawing.....	175
Further Information	179
Dimensioning a Drawing	180
Dimensioning Fundamentals.....	181
Dimensioning With Creo Elements/Direct Drafting	186
Preparing to Dimension	192
Single Dimensioning	194
Chain Dimensioning	199
Datum Dimensioning.....	203
Radius, Diameter, Tangential, and Arc Dimensioning	209
Angle and Chamfer Dimensioning	217
Geometry-Sensing Assignment.....	221
Database-Matching Assignment.....	225
Dual Dimensioning.....	231
Common Interrupt Functions.....	232
Predefining Prefixes, Postfixes, Superfixes, Subfixes, and Tolerances	236
Selection Filtering	237
Setting and Changing Dimensioning Attributes	243
Setting Line Attributes	243
Setting Text Attributes	254
Changing Line Attributes	269
Setting the Offset Point.....	274
Setting Dimension Offset.....	275
Changing Text Attributes.....	276
Setting Dimension Attributes with the STYLE Table	293
Modifying Dimensions	297
Modifying Dimension and Extension Lines	300
Modifying Chain and Datum Dimensions.....	304
Modifying a Dimension Vertex	305
Grouping.....	305
Further Information	305
Hatching a Drawing	306
Hatching a Drawing Area	307
Converting Hatch to Geometry	309
Deleting Hatching.....	310
Setting Hatch Parameters.....	310
Setting the Hatch Linetype and Color.....	312
Setting Hatch Patterns.....	313
Changing Hatch	315
Hatching Around Text and Dimension Text	318
Setting Up Standard Hatch Patterns	319
Further Information	321
Adding Text to a Drawing.....	322

Entering Text	323
Editing and Deleting Text	326
Setting Text Parameters	327
Modifying Text	330
Drawing Leaders and Terminators	333
Setting Terminator Size and Type	333
Setting Fonts	334
Setting the Text Frame	336
Changing Text	337
Changing the Text Frame	340
Listing Fonts	340
Changing Fonts	341
Font Editor	341
Converting Text to Geometry (DXF/DWG and IGES 2D Translation)	345
Grouping	345
Further Information	345
Adding Symbols to a Drawing	346
Geometric Tolerancing Symbols	347
Surface Symbols	356
Welding Symbols	363
Grouping	371
Handling Parts and Assemblies	372
Introduction to Parts	375
Parts Structure Explained	375
Creating an Assembly Drawing	378
Deleting Parts	382
Modifying Parts	383
Editing Parts	384
Initiating a New Empty Part	385
Making the Parent Part Active	386
Creating Parts	386
Gathering Elements Into Other Parts	389
Gathering Dimensions into Other Parts	391
Gathering Parts	392
Showing Parts	395
Smashing Subparts	396
Sharing Parts	398
Unsharing Parts	400
Working with the Parts Editor	401
Producing a Parts List	403
Viewing Parts	406
Spotlighting Parts	407
Changing Parts into Symbols	407
Setting the Part Reference Point	408
Renaming Parts	408
Multiple Drawing Scales	409

Scaling Parts about a Reference Point.....	411
Unique Partnames	411
Further Information	412
Generating Hidden Lines.....	413
Introduction to Hidden Lines.....	414
Hidden Line — Tutorial Example 1.....	419
Setting the Current Offset	424
Setting Z-Values	424
Generating Faces and Setting Z-Values in a Complete Part.....	427
Checking Z-Values.....	428
Generating Faces	433
Deleting Covering Faces	435
Redrawing in Hidden or Normal Mode	436
Coloring Faces	437
Viewing a Range of Z-Values	438
Generating Hidden Lines	440
Loading the Backup Drawing	441
Setting How Hidden Lines are Displayed.....	441
Plotting Hidden Lines	443
Dumping Hidden Lines	443
Hidden Line – Tutorial Example 2.....	443
Creating the Crank Assembly.....	443
Using Layers and Infos.....	449
Drawing Using Layers	450
Setting the Active Layer.....	453
Duplicating Elements in Other Layers.....	453
Moving Elements Between Layers.....	453
Using the Show Block with Layers	454
Modifying and Deleting Layers	455
What are Infos?	455
Editing an Info.....	457
Deleting an Info.....	458
Changing Infos	459
Listing Infos.....	460
Listing Namespaces.....	460
Using the Show Block with Infos.....	461
Further Information	461
Storing, Loading and Filing	462
File Organization and Names	463
Identifying Files.....	464
Loading and Storing Drawings Using File Browser.....	466
Importing a Bitmap File.....	471
Transparency	475
Loading a Drawing or Part (Filename Method).....	477
Storing a Drawing (Filename Method).....	480
Creating a New Creo Elements/Direct Drafting Instance.....	483

Opening an Existing Drawing File in a New Creo Elements/Direct Drafting Instance.....	483
Viewing the Catalog	484
Listing Catalog Items.....	485
Sorting the Catalog	489
Selecting the Current Directory	491
Copying Files and Directories	492
Purging Files or Directories.....	496
Creating Directories	500
Editing Files.....	500
Inputting Files	501
Saving Files.....	501
Revision Checking	502
Using Revision Checking.....	504
Annotation	507
Introduction	508
Loading an Annotation Drawing	511
Using the Sheet Browser to Navigate among Sheets and Views	511
Views.....	512
Showing Differences in a View Following a 3D Change	513
Handling Annotation Elements	514
Dimensions	514
Sheets	515
Hiding, Deleting, Unhiding	516
Unhiding Elements.....	516
Changing Colors, Linetypes and Hatches.....	517
Showing and Storing	517
Storing the Drawing for Further Use in Annotation	518
Plotting Drawings and Dumping Screens.....	519
Creating a Print Configuration	520
Defining the Plotting Parameters	520
Starting a Plot.....	530
Spool Plotting	531
Writing a Creo Elements/Direct Drafting Screendump to an Output File.....	531
Truecolor Plotting.....	532
Further Information	533
Grouping.....	534
Create a group.....	535
Managing drawings with Windchill.....	537
Activating the Windchill PDM Actions from Creo Elements/Direct Drafting.....	538
Windchill PDM commands	538
Customizing	541

Assigning Creo Elements/Direct Drafting Commands to Mouse Buttons	542
The Creo Elements/Direct Drafting Toolbox.....	542
Index.....	554



Preface

Creo Elements/Direct Drafting is a versatile 2D design and drafting system for optimizing each stage of the design process. Using Creo Elements/Direct Drafting you can quickly and easily create and modify 2D drawings.

Creo Elements/Direct Drafting provides a full set of commands for constructing, modifying, annotating, viewing, measuring, and plotting a 2D drawing.

Using a mouse you can:

- Perform real time zoom-in and zoom-out.
- Pan in real time, across the entire drawing or a zoomed-in portion.

Who Should Use This Manual

Read this manual if you are a:

- Design engineer
- Industrial designer

The Creo Elements/Direct Drafting documentation set is designed to help you learn to use Creo Elements/Direct Drafting quickly and easily. It consists of:

- Creo Elements/Direct Drafting User's Guide
- Installing and Configuring Creo Elements/Direct Drafting
- Writing Macros with Creo Elements/Direct Drafting
- Creo Elements/Direct Drafting Interfacing

This manual is written for users who have limited experience with CAD software.

Purpose of this Manual

This manual gives information on:

- Setting up Creo Elements/Direct Drafting for your particular environment.
- The Creo Elements/Direct Drafting user interface.
- Using the Creo Elements/Direct Drafting commands and functions.
- Using the dynamic graphic facilities.
- Working with parts and assemblies.
- How to generate hidden lines.

How to Use This Manual

Use this manual for both day-to-day use and reference. Each section contains:

- A description of the command or function.
- The procedure used to perform the given task.
- A tutorial example (when required).
- Any reference material required.

How This Manual is Organized

This manual is organized in the same order as the way you are likely to use Creo Elements/Direct Drafting:

Chapter 1	Getting Started With Creo Elements/Direct Drafting: a brief overview of the Creo Elements/Direct Drafting user interface and provides hints to help in getting started.
Chapter 2	Preparing the Drawing Environment: how to set up the environment and store it as a file.
Chapter 3	Commonly Used Commands: how to escape from a current activity.
Chapter 4	Changing the Environment and Making Measurements: how to change the environment in which the drawing is produced and how to measure distances on your drawing.
Chapter 5	Using Creo Elements/Direct Drafting's Copilot Functionality: how to create a design drawing with the minimum of construction geometry.
Chapter 6	Drawing Methods: how to create a drawing with or without the aid of construction geometry.
Chapter 7	Modifying a Drawing: how to modify your drawing.
Chapter 8	Dimensioning a Drawing: how to automatically dimension a drawing.
Chapter 9	Hatching a Drawing: how to hatch drawing sections.
Chapter 10	Adding Text To a Drawing: how to add text to a drawing.
Chapter 11	Adding Symbols to a Drawing: how to add geometric tolerance symbols and other special annotation to your drawing.
Chapter 12	Handling Parts and Assemblies: how to use parts and assemblies when creating drawings.
Chapter 13	Generating Hidden Lines: how to generate hidden lines in assembly drawings.
Chapter 14	Using Layers and Infos: how to use layers and how to add textual information (infos) to elements in your drawing.
Chapter 15	Storing, Loading, and Filing: how to load and save your Creo Elements/Direct Drafting drawing files.
Chapter 16	Revision Checking: how to compare revised drawings.
Chapter 17	Creo Elements/Direct Annotation: how to visualize, annotate, and edit MI files created by means of Creo Elements/Direct Annotation.

Chapter 18	Plotting Drawings and Dumping Screens: how to plot your finished drawing and how to dump screens.
Chapter 19	Collaboration: how to run collaboration meetings from within Creo Elements/Direct Drafting.

Typographical Conventions

This manual uses the following typographical conventions:

Table 1. Conventions Used in This Manual

Conventions	Represents
Bold	Menu paths, dialog box options, buttons, and other selectable elements from the user interface.
<code>Courier</code>	User input, system messages, directories, and file names.

This manual covers the Creo Elements/Direct Drafting Classic user interface on Windows-based systems.

1

Getting Started with Creo Elements/Direct Drafting

The Creo Elements/Direct Drafting User Interface.....	18
Basic Working Methods	20
What are Viewports?	23
Positioning Menus	24
How to Delete Elements.....	24
How to Store a Workfile	25
Autosave	25
Getting Help.....	25
Switching Languages	26
Switching Between Flat and Raised Menu Buttons.....	26
Switching the Beeper On or Off	27
Further Reading	27

This chapter provides a general overview of the Creo Elements/Direct Drafting user interface.

The Creo Elements/Direct Drafting User Interface

The Creo Elements/Direct Drafting user interface is designed to ensure a short learning curve and to provide maximum efficiency in 2D CAD projects. All of the menus, commands, functions, settings and tools specified in this manual are accessible via the Creo Elements/Direct Drafting user interface.

You can use Creo Elements/Direct Drafting either in screen-only. In screen-only mode, you will access the entire Creo Elements/Direct Drafting functionality by means of a mouse and your keyboard. The following figure indicates the screen layout of the Creo Elements/Direct Drafting screen-only version.

Figure 1. Screen-Only Display Layout

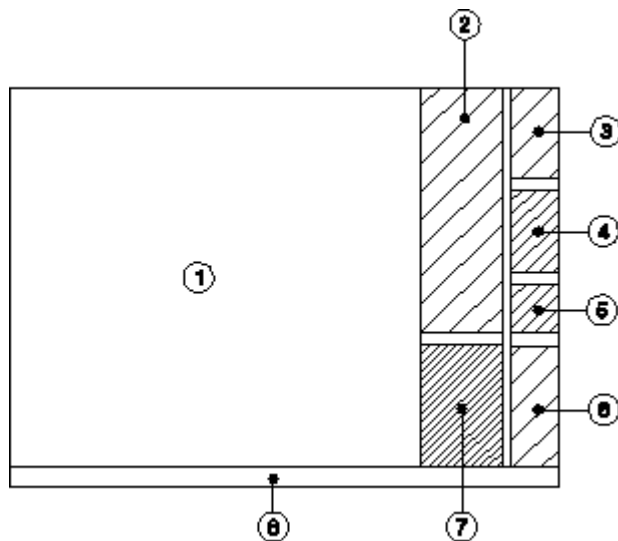

- 1 Drawing area. This is the area where you will create and modify drawings.
- 2 Command menu. Displays the commands and options available through the current menu.
- 3 Command section. Click any of these menu commands to display the associated menu.
- 4 Command section. Contains frequently used commands.
- 5 Additional Modules section. Enables you to access further modules integrated with Creo Elements/Direct Drafting.
- 6 Interrupt functions, viewports, and Toolbox.
- 7 Window area for interrupt functions, viewports, and Toolbox
- 8 System status bar, system prompt line, user input line. These provide general user guidance and feedback.

Optionally, you can run multiple Creo Elements/Direct Drafting instances (in separate Creo Elements/Direct Drafting windows) at the same time. Refer to [Creating a New Creo Elements/Direct Drafting Instance on page 483](#) for further information.

General User Guidance and Feedback

The System Status Bar, the System Prompt Line, and the User Input Line at the bottom of the Creo Elements/Direct Drafting display provide general guidance and feedback.

- System Status: Bar provides information on the current state of Creo Elements/Direct Drafting.
- System Prompt Line: displays messages to guide you through the commands.
- User Input Line: displays the data you enter via the keyboard.

Figure 2. System Status Bar on page 19 shows an example of a System Status Bar.

Figure 2. System Status Bar

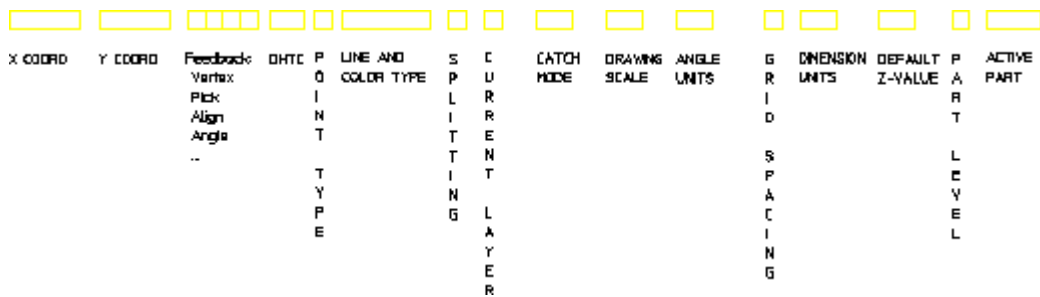

Note

For the SHOW and SPLITTING status, uppercase characters are displayed for ON and lowercase for OFF. If an S is displayed in the parts level position it means that you are working on a shared part.

The letters DHTC in the above figure stand for: Dimension, Construction Geometry, Hatch and Text. Refer to [Visibility Indicator \(DHTC\) on page 78](#) for details.

Changing the Status Bar Colors

Optionally, you can change the status bar colors by entering the following in the user input line:

- CMD_BG_COLOR followed by a color name to change the background color of the user input line.
- CMD_TXT_COLOR followed by a color name to change the color of the text on user input line.

Using the Dynamic Mouse

To use the dynamic mouse, press and hold the [Ctrl] key and press one of the following mouse buttons:

Left Button	Panning horizontally and vertically.
Right Button	Zooming: <ul style="list-style-type: none">• Towards the screen: zooms in• Away from the screen: zooms out
Middle Button	Not assigned

- The full functionality is available on a three-button mouse. If a two-button mouse is used, press the left and right button simultaneously to emulate the middle button.
- This functionality is available on screen-only versions of Creo Elements/Direct Drafting.
- Whenever the user definable buttons are pressed, the corresponding string value for that button is displayed on the user input line.
- If your drawing contains images (pixmap), you can hide these using the SHOW Box command before doing any dynamic operations. This improves system performance.

Additional Information:

- The full functionality is available on a three-button mouse. If a two-button mouse is used, press the left and right button simultaneously to emulate the middle button.
- This functionality is available on screen-only versions of Creo Elements/Direct Drafting.
- Whenever the user definable buttons are pressed, the corresponding string value for that button is displayed on the user input line.
- If your drawing contains images (pixmap), you can hide these using the SHOW Box command before doing any dynamic operations. This improves system performance.

Basic Working Methods

It will not take you very long to become familiar with Creo Elements/Direct Drafting, but a few hints may help you to get started.

The best way to learn is to practice, and we recommend you try the examples given in this manual. If you need further explanation of any of the 2D functions or commands, refer to this manual. It contains a description of how to use each command or function.

An index is included at the back of the manual; this contains not only the command and function names but also a task reference.

Many operations require similar user interaction. For example, you will often be prompted to identify an element, enter a value, enter a filename, or indicate a point.

Some of the most commonly used terms are listed below:

Identifying an Element or a Point

This implies that the element or point already exists. Identify it by:

- Pressing the cursor at the appropriate position.
- Entering the coordinates separated by a comma.

Indicating a Point

This implies that the point chosen could be anywhere on the drawing and may or may not be marked by an existing point. Again, the point required is indicated by:

- Pressing the cursor at the appropriate position.
- Entering the coordinates separated by a comma.

Entering a Value

Entering a value means entering the value and pressing [Enter]. For certain commands and functions you must enter a numerical value, and for others a string enclosed in quotes ' ' or " ". Additionally, values to be entered can be first calculated by typing the appropriate mathematical expression in parentheses:

(15 * tan 30)

Undo and Redo

In Creo Elements/Direct Drafting, you can undo mistakes with **Undo** / **Redo**.

Click  to undo an operation (before you click **Confirm**)

Click  to redo an operation (after you have clicked **Undo**).

Each time you click **UNDO** or **REDO**, you will undo or redo all the changes that were created by the last command you entered.

You can set a limit on the number of steps to keep in the **UNDO** or **REDO** history in the System Setting dialog.

1. In the main menu, click **Setup ▶ Edit Environment ▶ System**.
2. You can select:
 - **-1**: no limit.
 - **0**: disable the Undo/Redo option.
 - **+*[number]***: the maximum number of steps you can undo or redo when no command is active. If you already have more steps in your history than the number you selected as the limit, Creo Elements/Direct Drafting will automatically delete the extra steps.

Limitations:

- You can undo or redo complete macros, but you cannot use **UNDO** or **REDO** inside macros.
- **UNDO** or **REDO** cannot undo or redo:
 - Commands related to parametric design, hidden lines, PIXMAPs, or OLEs. Once you have executed one of these commands, you can no longer undo or redo any of your previous commands.
 - The `RESET_SYSTEM` command.
 - Commands for default settings (although these commands do not affect the undo/redo history).

Undo and Redo with state history

Each time you enter a command and change your drawing, Creo Elements/Direct Drafting adds a new state to the undo/redo history. Creo Elements/Direct Drafting marks the new state with a unique ID. With this information, you can:

- Use `UR_GET_CURRENT_ID` to see the ID of the current undo/redo state.
- Use `UR_ID_EXISTS` to see if a specified ID exists in the undo/redo history.
- Use `UR_GET_FIRST_ID` to see the ID of the first state in the undo/redo history.
- Use `UR_GET_LAST_ID` to see the ID of the last state in the undo/redo history.
- Use `UR_MOVE` to undo/redo the drawing to a specified state.

What are Viewports?

A viewport is a rectangular area on the screen whose position and size you can define. Specific parts of your drawing can be displayed in the viewports. This then enables you to study the drawing or add information with greater ease and accuracy. You can create up to 16 viewports but usually between 2 and 6 are sufficient.

The viewports are identified by a number in the top right hand corner. You will notice one is in inverse video – this is the current viewport. All window functions operate on the current viewport, for example, if you press **NEW** and make a box in any viewport the new view will be drawn in the current viewport. Any viewport can be made current by either picking the identification number on the screen or by pressing the **CURRENT** function in the **VIEWPORT** menu.

In Creo Elements/Direct Drafting, you can overlap viewports with other viewports, menus, and programmable tables, without any limitations in functionality. All overlapping viewports are permanently updated during your drawing session.

The VIEWPORT menu of the screen-only version includes the command buttons **Select**, **Move**, and **Set**. **Set** allows you to define the viewport's color and its border width. Additionally, the screen-only viewport menu provides a status area for the viewports. Click a button in this status area to define a single or all viewports.

The bottom row of the viewport menu provides combined commands. **CurVP1** and **CurVP2** create two viewports and set either viewport 1 or viewport 2 current. **4 VPs** creates 4 predefined viewports.

Figure 4. Viewport Menu

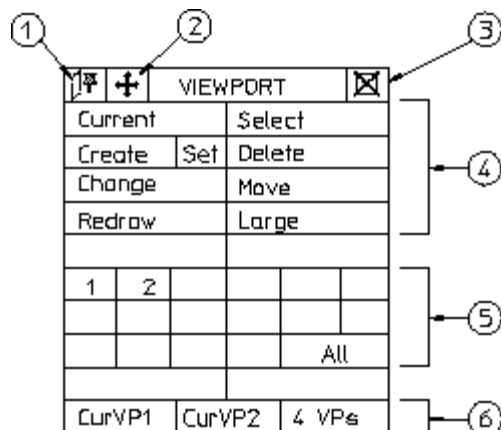

The icons marked 1 to 3 can also be found in all other menus.

1. Pin the menu
2. Move the menu
3. Close the menu

4. Commands
5. Status area
6. Combined commands

Positioning Menus

You can position Creo Elements/Direct Drafting menus anywhere on the screen and pin them so that when they are recalled, they open in the same position. The title bar of each menu provides the following icons:

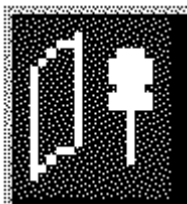

This icon indicates that the menu is currently unpinned. Pick this icon to pin the menu.

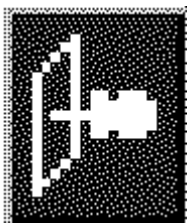

This icon indicates that the menu is currently pinned. Pick this icon to unpin the menu.



Pick this icon to move a menu to a new position.

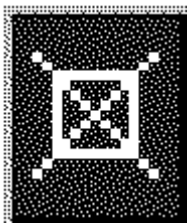

Pick this icon to close a menu.

How to Delete Elements

As you learn to work with the system you are sure to make mistakes. To delete an element or piece of text:

-
1. Press the **DELETE** block.
 2. Identify the element or text to be deleted. (If you make a mistake you can restore the element or text by pressing **UNDO**.)

How to Store a Workfile

To prevent loss of your drawing (due to power failure, for example) you should store the workfile regularly (every 10 to 15 minutes is recommended).

To store your workfile:

1. Press **FILE**.
2. Pick **STORE**.
3. Pick 'workfile'.

Autosave

Creo Elements/Direct Drafting provides an autosave feature to automatically save a drawing at routine intervals. (Autosave is set by the command `AUTO_STORE_TIME`.)

- The autosaved file is `me_backup.mi`. The file is put in the working directory as specified by `ME_WORKING_DIR`.

If `ME_WORKING_DIR` is not defined, the file is stored in `\temp` on Windows-based systems.

- The autosave interval is a time interval in minutes. Possible values are 10 and 0 (0 is off, this is the default).
- While the autosave is running, a message pops up and the blue store bar displays the progress.

Getting Help

The help file contains technical reference information about all the commands and functions that you can use within Creo Elements/Direct Drafting.

To use the help system:

1. Press **HELP**.
2. Input the command or function on which you require help by either:
 - Picking a command or function from the screen menu.
 - Entering the command or function name.

Creo Elements/Direct Drafting responds by displaying the required help information in a separate browser.

Switching Languages

By default, the Creo Elements/Direct Drafting user interface is displayed in English. To switch to the language of your choice, enter the appropriate command in the user input line:

Language Command	
English	<code>change_locale 'en'</code>
French	<code>change_locale 'fr'</code>
German	<code>change_locale 'de'</code>
Italian	<code>change_locale 'it'</code>
Spanish	<code>change_locale 'es'</code>
Japanese	<code>change_locale 'ja'</code>

Alternatively, specify this command above the `Startup_menus` string in the `startup.m` file contained in the Creo Elements/Direct Drafting installation directory.

Note

The Japanese version of Creo Elements/Direct Drafting requires a Japanese operating environment.

If you installed Creo Elements/Direct Drafting in Custom mode, any languages you deselected during installation will not be available at Creo Elements/Direct Drafting runtime.

Switching Between Flat and Raised Menu Buttons

The `MEPELOOK` variable in the `me10.ini` file (located in the Creo Elements/Direct Drafting installation directory) enables you to select either the "flat" look or the "raised menu buttons" look of the Creo Elements/Direct Drafting Classic user interface:

Switching the Beeper On or Off

Optionally, you can switch the "beeper" on or off in Creo Elements/Direct Drafting. Simply enter `BEEPER` and then `ON` or `OFF` into the user input line.

Further Reading

You can now begin to use Creo Elements/Direct Drafting to produce high quality 2D drawings.

When you are ready to learn more about the system and its command structure refer to your *Writing Macros with Creo Elements/Direct Drafting*, which contains advice on macro writing and command syntax.

2

Preparing the Drawing Environment

Editing the Creo Elements/Direct Drafting Environment	29
Saving the Creo Elements/Direct Drafting Environment to a File	30
The Creo Elements/Direct Drafting Environment Listing	31
Setting Linear and Angular Units	31
Loading a Drawing Frame	32
Setting the Drawing Scale	33
Switching Copilot Functionality On and Off	33
Further Information	34

Editing the Creo Elements/Direct Drafting Environment

The Creo Elements/Direct Drafting environment specifies various settings, which determine, for example:

- Dimension appearance.
- Text appearance.

Some of the settings can be set in a particular menu, such as Text Size in the **TEXT 1** menu, while many of the dimension settings can be set using the commands contained in the Creo Elements/Direct Drafting environment.

To edit the environment, press **SETUP 1** to display the environment settings for frequently-used items such as text and line geometry. To change less frequently-used items, click **EDIT ENV**.

Setting the Environment

The **EDIT ENV** command options are:

Text	Edit the text settings, for example, text size.
Geometry	Edit the geometry settings, for example, line color.
Hatch	Edit the hatch settings, for example, hatch distance.
Dimensions	Edit the dimension settings, for example, dimension offset.
Dim Filter	Edit the filter settings, for example, dimension circles.
Plot 1	Edit the plotter settings, for example, plotter type.
Plot 2	Edit the plotter transformation settings.
Sys Env 1	Edit the system environment settings, for example, switching spotlight on or off.
Sys Env 2	Edit the system environment settings, for example, search paths.

The **SAVE ENV** command options are:

Screen	Outputs the environment to the screen.
Printer	Outputs the environment to a printer.
Append	Appends the environment to an existing environment.
Delete Old	Overwrites the existing environment file.

For example, to change the hatch distance:

1. Click **Hatch** in **EDIT ENV**
2. Click table entry `HATCH_DIST` and enter 2

3. Click **Update** to update the table

Setting the Preview Mode

The `PREVIEW` command specifies whether or not to save a preview image of a drawing. The default is on.

When you store a drawing, Creo Elements/Direct Drafting saves the drawing as usual and simultaneously creates a preview image. The next time you display the File Browser, you can display the image in the preview window. (See also [Previewing Drawings on page 469](#))

Saving the Creo Elements/Direct Drafting Environment to a File

OSD saves your environment settings when you exit Drafting. The settings are saved to `<application data path>\PTC\Creo Elements Direct Drafting [version]\[version]`

If you wish to save a particular Creo Elements/Direct Drafting environment, use the `SAVE ENV` command to store the information in a file; you can then input the file at the start of a drawing session (Enter `INPUT 'filename'`).

To store the present environment:

1. Press **SETUP 1**.
2. Pick `SAVE ENV`.
3. Enter the name of the file (for example, "Company_environment").

Creo Elements/Direct Drafting will now store the environment under the entered filename.

To set Creo Elements/Direct Drafting with a previously stored environment file:

1. Press **FILE**.
2. Pick `INPUT`.
3. Enter the environment filename (for example, "Company_environment").

Creo Elements/Direct Drafting will set the system according to the environment file you have named.

Further details of using the environment file are contained in the manual *Writing Macros with Creo Elements/Direct Drafting*.

The Creo Elements/Direct Drafting Environment Listing

Part of a typical environment listing is shown below:

```
SEARCH
  '/opt/CoCreate/Drafting'
END
MAX_FEEDBACK 100
CONFIGURE_EDITOR '$' 1 79
UNITS 1 INCHES
UNITS 1 DEG
CS_REF_PT 0,0
CS_AXIS 1,0 0,1
FOLLOW OFF
GRID_FACTOR 0.5
CURRENT_FONT 'hp_i3098_v'
TEXT_FRAME OFF
TEXT_ANGLE 0
TEXT_ADJUST 1
TEXT_LINESPACE 2
TEXT_FILL OFF
TEXT_SIZE 0.125
TEXT_RATIO 1
TEXT_SLANT 0
LINE WHITE SOLID END
C_LINE RED DOTTED END
TEXT WHITE END
SPLITTING ON
```

Setting Linear and Angular Units

Pick **UNITS** to set the current linear and angular units. The units set are displayed in the System Status Line. Normally, you will set the current units before starting to draw. However, if you reset the current units after you have started to draw, Creo Elements/Direct Drafting will automatically convert all existing elements without changing the lengths.

For example, if you set the current units to meters and draw a line one unit long, when you change the current units to millimeters the line will measure 1000 units.

The following options are available:

Linear units:

Inches	Micro-In
Feet	Yards
Miles	Mils
mm	cm

Meters	Micrometer
km	User

Angular units:

Degrees	Gradians
Radians	User

To set the current linear and angular units:

1. Press **SETUP 2**.
2. Pick the required option in **UNITS**.

Defining Your Own Units

The option User allows you to define your own units. For example, an input of 5mm allows you to work in 5mm units, and an input of 5 degrees allows you to work in 5 degree units.

To define your own units:

1. Press **SETUP**.
2. Pick User.
3. Enter your required units.

Loading a Drawing Frame

With the `LOAD FRAME` command, load a standard size plotting frame into your drawing. The frame can then be used to aid positioning of the various views in your drawing.

The frame is a symbol part which is always loaded below the Top part in level 1 (refer to [Handling Parts and Assemblies on page 372](#)). Each frame consists of two concentric rectangles: the outer one the size of the respective paper size, the inner one between 10 to 50 mm smaller per side.

The frames are drawn in magenta with the dotted linetype and therefore will not normally be plotted out.

Drawing frame part names have the form: `frame_A4[symbol]`, `frame_A3[symbol]`, and so on.

The ten frame options are:

A	A4
B	A3
C	A2
D	A1
E	A0

To load a drawing frame into your drawing:

1. Press **SETUP 1**.
2. Pick the paper size in **LOAD FRAME**.
3. Indicate the location or enter **ABSOLUTE**.

Setting the Drawing Scale

Pick **DRAW SCALE** to set the drawing scale. The value set will affect only the physical size of construction and drawing lines during plotting. Dimensions, text, and symbols are not affected by this command. The drawing scale is displayed in the System Status Line.



Note

The maximum drawing scale is 99999.

For example with the drawing scale set at 2, a line drawn 100 mm long will be plotted out 200 mm long.

To set the drawing scale:

1. Press **SETUP 1**.
2. Pick **DRAW SCALE**.

Creo Elements/Direct Drafting displays the current drawing scale on the prompt line.

3. Enter the new drawing scale.

The result can be checked by looking at the System Status Line.

Switching Copilot Functionality On and Off

You can switch the Copilot functionality on or off via the **SETUP 1** menu. The current Copilot status is indicated in the System Status Bar. When the Copilot functionality is switched on, the snapping distances and angles can be set. For more information, refer to [Using Creo Elements/Direct Drafting's Copilot Functionality on page 94](#).

Further Information

For further technical information about the Creo Elements/Direct Drafting environment, refer to the Creo Elements/Direct Drafting help system:

Enter `help environment` at the Creo Elements/Direct Drafting command line.

The screen will clear and Creo Elements/Direct Drafting will display further information about the environment.

3

Commonly Used Commands

Deleting Elements	36
Selecting Drawing Elements.....	38
Confirming Commands	48
Undoing Commands.....	48
Ending a Command.....	48
Canceling Commands	48
Getting Help.....	48

Most of these commands have a similar purpose; they allow you to escape from whatever activity is currently being performed. The knowledge that you can easily delete or cancel any mistakes should help you gain confidence in using Creo Elements/Direct Drafting.

Deleting Elements

Press **DELETE** to delete drawing elements or pieces of text.

DELETE can be used together with the **SELECTION** mechanism.

For example, to delete everything on the screen:

1. Press **DELETE**.
2. Press **ALL** in **SELECTION**. Creo Elements/Direct Drafting will then prompt you to press **CONFIRM** before everything is deleted.
3. Press **CONFIRM**.

Remember, if you make a mistake, you can restore the element by pressing **UNDO** (before you have pressed **CONFIRM**). You can also enclose the elements to be deleted in a box.

To delete an element or text:

1. Press **DELETE**.
2. Identify the element or text to be deleted (you can also enclose the elements to be deleted in a box).

Deleting Hatching

To delete hatching, use the **DELETE** command in the Hatch menu, then identify the hatching to be deleted individually. See [Hatching a Drawing on page 306](#) for more information.

Highlighting Elements Before Deletion

The **SELECTION** mechanism makes it possible to identify the elements that you want to delete (or modify) and to see them highlighted on the screen before deletion:

1. Press **DELETE**.
2. Pick **SELECTION** followed by any option or combination of options described below.
3. When you are satisfied that the elements to be deleted have been correctly identified, press **CONFIRM**.

Global Selection

Each time you select components, you can decide whether you want to select from the current part or from the whole parts tree. Global selection allows you to select components from the whole parts tree:

1. Press **SELECTION**.
2. Press **GLOBAL**.

If you do not specify **GLOBAL**, Creo Elements/Direct Drafting defaults to the current part.

Example

Press **DELETE, SELECTION, GLOBAL, ALL, CONFIRM**

This command string deletes all components of the parts tree even if the active part is not the top part.

It should, however, be noted that even though all components (geometry, construction geometry, and text) contained within the parts tree will be deleted, it is not possible to delete the complete parts tree. The current part is never deleted and a path linkage to the top part is always maintained.

Several examples using the parts structure in [Figure 5. Example Parts Structure on page 37](#) show the power of **SELECTION**.

Figure 5. Example Parts Structure

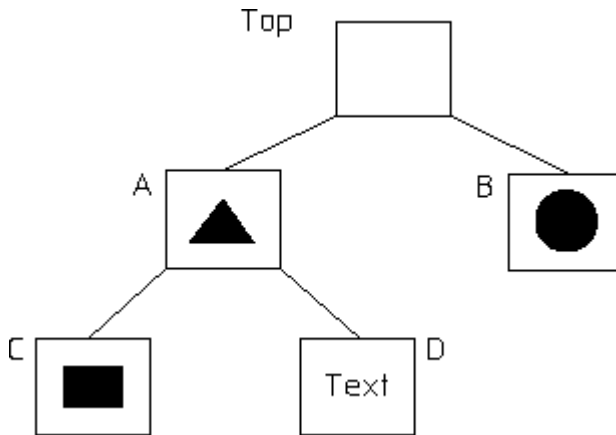

If you delete globally with 'B' as the active part, the Top part and 'B' will remain. See [Figure 6. Top Part and 'B' on page 37](#).

Figure 6. Top Part and 'B'

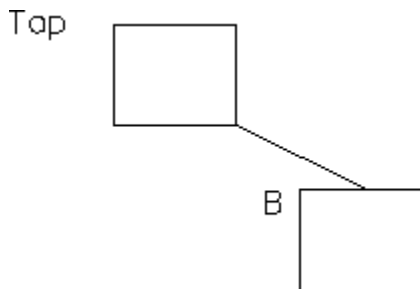

If you delete globally with 'A' as the active part, the Top part and 'A' will remain. See [Figure 7. Top Part and 'A'](#) on page 38.

Figure 7. Top Part and 'A'

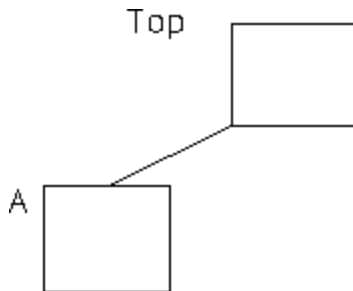

If you delete globally with 'D' as the active part, the Top part, 'D', and its parent, 'A', will remain. See [Figure 8. Top Part + D + A](#) on page 38.

Figure 8. Top Part + D + A

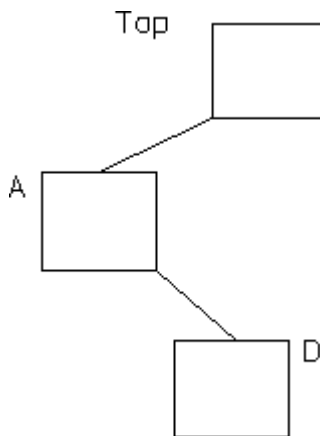

Selecting Drawing Elements

Press **SELECTION** to let Creo Elements/Direct Drafting know you are about to make a selection. Then press any option or combination of options from the selection block.

All options on the selection block can be chosen directly without pressing **SELECTION**. However, if you do not press **SELECTION** first:

- The elements you choose will not be highlighted on the screen for you to view before the operation of your choice. For example, deleting will be performed immediately.
- You will not be able to use the options **Add**, **Subtr**, **Not**, and so on. Note that you can only enter **NOT** via the keyboard.

 **Note**

If you want to select elements drawn in a particular color or linetype you must first press **SELECTION** and then specify the respective color or linetype.

Example

Press **DELETE, SELECTION, GREEN, ALL, CONFIRM**

This will delete all elements drawn in green in the current part.

General Selection Functions

Press **SELECT** to let Creo Elements/Direct Drafting know you are about to make a selection (for example, to move or to delete elements). Then press any option or combination of options from the **SELECT 1** or **SELECT 2** menu.

Option	Description
Select	Initiates a selection.
Add	Adds the next elements you select to the current result.
Subtr	Subtracts the next elements you select from the current result.
And	Results in a logical AND (set intersection) of the current result and the elements selected next.
Or	Results in a logical OR (set union) of the current result and the elements selected next.
Exor	Results in a logical EXOR (exclusive OR) of the current result and the elements selected next.
Not	Unselects the current result. All other elements become the current result.
PreSel	Selects the current preselection. See Preselecting Elements on page 47 .
CONFIRM	Confirms a selection.

Element-Related Selection Functions

The element-related selection functions are included in the **SELECT 1** and **SELECT 2** menus.

In SELECT 1

Option	Description
All	Selects all elements in the active part.
Info	Selects infos.
Layer	Selects layers.
Box	Selects all elements you enclose in a box.
Vertex	Selects vertices.
Text	Selects text.
Dim	Selects dimensions.
C-Geo	Selects construction geometry.
Geo	Selects geometry.
Part	Selects parts.
Subtree	Selects a subtree of a part or an assembly.
Global	The selection applies to the entire parts tree.
G-Perm	Global Permanent. The selection, and all those that follow for this command, apply to the entire parts tree.
Poly	Selects all elements you enclose in a polygon.
Edit Dim	Selects edited dimensions.
URL	Selects URLs.

In SELECT 2

Option	Description
Point	Selects points (singularities) but not vertices.
Line	Selects geometry lines.
Arc	Selects arcs.
Fillet	Selects fillets.
Circle	Selects geometry circles.
Spline	Selects splines.
C_lin	Selects construction lines.
C_cir	Selects construction circles.
Leader Line	Selects leader lines.
Polyel	Selects polyelements.
Hatch	Selects hatches.
CL_lin	Selects center lines.
Symlin	Selects symmetry lines.
Reflin	Selects reference lines.
PRPs	Selects projected reference points.
Color	Selects colors.

Option	Description
LType	Selects linetypes.
PSize	Selects pensizes.
LSize	Selects linesizes.
Font	Selects fonts.
Contours	Selects contours.

Adding Elements to Your Selection

This option allows you to add elements, either selected individually or enclosed in a box, to your current selection. For example:

1. Press **DELETE**.
2. Press **SELECTION**.
3. Identify several elements to be deleted.
4. Press **ADD**.
5. Press **BOX**.
6. Enclose further elements to be deleted in a box.
7. Press **CONFIRM**.

Subtracting Elements from Your Selection

To subtract elements from your current selection press **SUBTR**.

Removing Elements from Your Selection

Enter **NOT** to make the previous selection result unselected, and all previously unselected elements to be treated as selected.

Note

Not always works globally on all parts.

Enclosing Elements in a Box

To select a group of drawing elements by enclosing them in a box:

1. Press **BOX**.
2. Enclose the required elements in a box.

They will then be shown in a different linetype and Creo Elements/Direct Drafting prompts you to **CONFIRM** that you want to delete them. Before you press **CONFIRM**, you may want to alter your selection by, for example, subtracting or adding some elements.

3. Press **CONFIRM**.

Enclosing Elements with a Polyline

If you need greater flexibility when selecting elements, use **POLYGON** to enclose elements within a polyline. This is particularly useful when elements are not symmetrically grouped horizontally and vertically.

Figure 9. Selecting Elements with Polyline

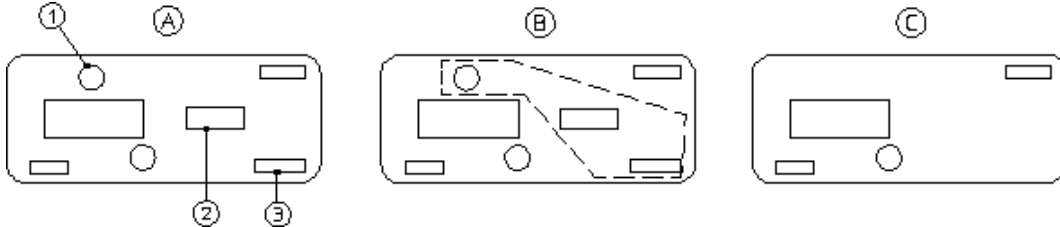

Suppose you want to delete the elements 1, 2, and 3:

1. Press **DELETE**.
2. Press **Poly** in **SELECTION**.
3. Pick a sequence of points to enclose elements 1, 2, and 3 in a polygon.
4. Close the polygon by picking the start point or enter **CLOSE**.

Selecting All Elements

To select everything contained in the current part (and subparts):

1. Press **DELETE**.
2. Press **ALL**.

Creo Elements/Direct Drafting prompts you to press **CONFIRM** if you really want to delete all elements selected. If not, press **CANCEL** and select again.

3. Press **CONFIRM**.

Selecting a Vertex

Press **VERTEX** if you want to delete all elements that share a specified point.

Selecting Elements Using Information Strings

Press **INFO** to select all elements that have a particular information string associated with them. You will be prompted to type in the information concerned.

Selecting Layers

Press **LAYER** to select all elements assigned to a specified layer. When you choose this option, the system prompts you for the layer information.

Selecting Text

Press **TEXT** to select the required text. Creo Elements/Direct Drafting prompts you to identify the text to be selected.

Selecting Construction Geometry

Press **C-GEO** to select and highlight construction geometry before deletion. Identify the construction lines and circles either individually or by enclosing them in a box. Press **CONFIRM** to delete them.

If you do not press **SELECTION** before **C-GEO** to select construction geometry, it will be deleted without first being highlighted.

Selecting Drawing Geometry

Press **GEO** to select and highlight drawing geometry before deletion. Press **CONFIRM** to delete them.

To make a selection on pensize or linesize:

1. Pick Select in **SELECT**.
2. Pick PSize or LSize in **SELECT 2**.
3. Enter a value (for example, 2).
4. Pick **CONFIRM**.

Selecting Parts

Press **PART** to select elements in a particular part.

Example

To delete a selected part from anywhere in the parts tree:

1. Press **DELETE, SELECTION, GLOBAL, PART**.

-
2. Enter `part_name`.
 3. Press **CONFIRM**

 **Note**

When deleting a part, you automatically delete all associated subparts.

Selecting Contours

The **Contrs** option in **Select** enables you to select contours (closed loops of connected elements).

 **Note**

To account for the fact that contours may be nested (closed loops of elements within other closed loops of elements), Creo Elements/Direct Drafting allows you to specify a contour level. See [Specifying the Contour Level on page 45](#) for details.

The general procedure is as follows:

1. Select a given subset (such as an area enclosed in a selection polygon) of your drawing.
2. Apply further selection criteria to refine your selection.
3. Click **Contrs** (in **SELECT 2**) to scan this refined selection for contours.

For example:

- To move all contours in your drawing by a given distance:
 1. Display the **MODIFY 1** menu and press **2 Pts** in **MOVE**.
 2. Click two points to define the distance and direction of the move.
 3. Press **Select, All** and **Contrs** in **SELECT**.
 4. Press **CONFIRM** to move the selected contours.
- To delete all elements other than contours:
 1. Press **DELETE**.
 2. Press **Select, All, Contours, Not** in **SELECT**.
 3. Press **CONFIRM** to delete all non-contour elements.
- To change the color of all contours to green:

1. Press **ChgCol** in **COLOR**.
2. Enter `green` as the new color.
3. Press **Select, All** and **Contours** in **SELECT**.
4. Press **CONFIRM** to change the color of all contours to green.

Specifying the Contour Level

To facilitate the selection of nested contours, Creo Elements/Direct Drafting enables you to specify a selection level by typing `contour_level` followed by an integer.

contour_level 0	This is the default. Only the "outer" contours in the selection polygon are selected. See the part labeled 0 in Figure 10. Contour Levels on page 46 .
contour_level 1	In addition to the outer contours, the first contours encountered within the outer contours are selected. See the part labeled 1 in Figure 10. Contour Levels on page 46 .
contour_level 2	In addition to the contours in contour level 1 (including all level 0 contours), the first contours encountered within level 1 contours are selected. See the part labeled 2 in Figure 10. Contour Levels on page 46 .
contour_level 3	In addition to the contours in contour level 2 (including all level 1 and level 0 contours), the first contours encountered within level 2 contours are selected. See the part labeled 3 in Figure 10. Contour Levels on page 46 .

Figure 10. Contour Levels

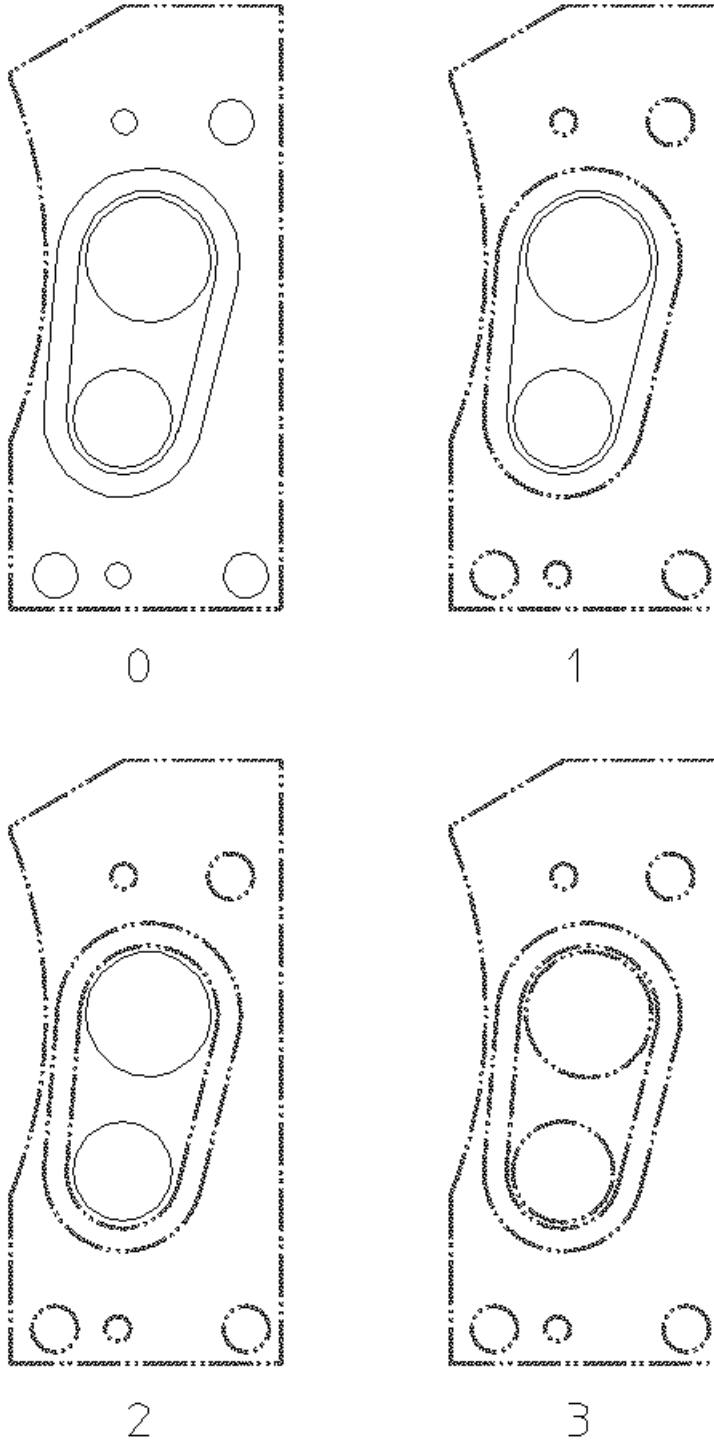

Copying Contours to the Clipboard

The `COPY_TO_CLIPBOARD` command enables you to select contours (closed loops of connected elements) to the Clipboard. Note that this command does not modify the drawing. From the Clipboard, the copied contours can be pasted to another place in the same Creo Elements/Direct Drafting drawing, to another Creo Elements/Direct Drafting drawing, or to Creo Elements/Direct Modeling.

Proceed as follows to copy a set of contours:

1. Specify the [Specifying the Contour Level on page 45](#) for the selection you are about to make.
2. Enter the following commands:
`COPY_TO_CLIPBOARD`
3. Press **Select, Poly** in **SELECTION**.
4. Click on points in your drawing to define a selection polygon around the area from which you want to select contours. Note that contours fully enclosed in this polygon are highlighted.
5. Press **Contrs** in **SELECT 2**.
6. Press **CONFIRM** and **END**.

For example, to paste the contours thus selected to another Creo Elements/Direct Drafting drawing, enter:

`PASTE_TO_CLIPBOARD`

Preselecting Elements

By preselecting elements, you can keep these available for subsequent operations. Creo Elements/Direct Drafting will "remember" your preselection until you replace it by another preselection.

Defining a Preselection

To preselect elements:

1. Press **PRESELECT**.
2. Select the elements you want to include in your preselection.
3. Press **CONFIRM**.

Retrieving a Preselection

To retrieve your preselection:

1. Press **PreSel** in **SELECT 1**.
2. Press **CONFIRM**.

Automatic Preselection

With automatic preselection enabled, you can add elements to the preselect list and use them in Modify menu commands without using the Select menu or Preselect command. To enable this option, click **Setup ► MENU 3**, and turn the **Auto Pres** option on.

Confirming Commands

Press **CONFIRM** to confirm that the deletion or modification you have defined should be implemented.

Undoing Commands

Press **UNDO** when you have just deleted or modified something but realize you have made a mistake. This will return you to the previous display.

Ending a Command

Press **END** to terminate the active command or function, whether or not you have completed it. You can also terminate any command or function by selecting another command.

In the case of functions, pressing **END** will terminate the currently active function, but the previously selected command will remain active.

Canceling Commands

It may happen that you select a series of commands and functions but do not complete any of them. Although selecting a new command will terminate whatever command or function is active and allow you to continue working, it is advisable to press **CANCEL** and then start again. Otherwise the response time may be slightly slower than normal.

Getting Help

The Creo Elements/Direct Drafting help system contains general technical information about all the commands and functions that you can use in Creo Elements/Direct Drafting.

To use the help system:

1. Press **HELP**.
2. Specify the command or function about which you require help by either:

-
- Pressing a command or function on the tablet.
 - Picking a command or function from the screen menu.
 - Entering the command or function name.

Creo Elements/Direct Drafting responds by displaying the required help information.

3. Press [Ctrl] [D] to return to the normal display.
4. Press [Esc] to return to the normal display.

 **Note**

Make sure that the MEHELPDIR variable in your Creo Elements/Direct Drafting startup script is set to the directory where Netscape is installed.

4

Changing the Drawing Environment and Making Measurements

Changing the Linetype	51
Changing Pensize and Linesize.....	54
Changing Color	56
Changing the Catch Mode.....	62
Measuring Distances	63
Using the Calculator	69
Using the Ruler/Grid	73
Selecting What is Displayed on Your Screen	76
Viewing a Drawing.....	78
Using Viewports to Display Several Views.....	88
Creating an Edit Port	91
Using Properties to Change Elements and Text	92

Use the functions shown in this chapter as an aid to make designing and drafting easier. They are arranged in groups of functions and are available for use at all times.

Functions are essentially different from commands in that a function can interrupt a command (or another function) without terminating it.

For example, while using the `FILLET` command to draw a fillet radius, you may want to window the corner concerned or change the current linetype. Both **LINETYPE** and **WINDOW** are interrupt function groups.

Once a function has been executed, control is automatically returned to the previously unfinished command in which you were working.

Changing the Linetype

The linetype functions are used for geometry, construction geometry, and hatching. To set the linetype of a particular group of elements:

1. Press **CREATE**.
2. Pick an option in **CREATE**.
3. Press the required linetype in **LINETYPE**.

This new linetype will then be displayed in the System Status Line. Creo Elements/Direct Drafting will retain this information. When you return to the **CREATE** menu and select a command, all lines will be drawn in the specified linetype.

Changing the Linetype of Existing Elements

Figure 11. Linetypes and Corresponding Point Symbols on page 51 shows the linetypes available and their corresponding point symbols. For a graphical overview of these linetypes, press **ALL** in **LINETYPE**.

Figure 11. Linetypes and Corresponding Point Symbols



Item	Description
1	Solid
2	Dashed
3	Long Dashed
4	Dot Center
5	Dash Center
6	Phantom
7	Center Dash Dash
8	Dotted

To change the linetype of an existing element:

1. Press **Chg LT**.
2. Press the required linetype in **LINETYPE**.
3. Indicate the element to be changed.

 **Note**

- The linetypes you choose on the screen will be plotted unless plot transformation has been altered (see PLOT_TRANSFORMATION and SCREEN_TRANSFORMATION in the online Help).
- Note that when plotted, PHANTOM and CENTER_DASH_DASH linetypes look the same.
- You can use the LINEPATTERN function to define your own linetype. Refer to Writing Macros with Creo Elements/Direct Drafting. If the linetype you have defined cannot be displayed or plotted, Creo Elements/Direct Drafting defaults to the nearest standard linetype shown in [Figure 11. Linetypes and Corresponding Point Symbols on page 51](#).
- The spacing of all broken linetypes is set using the plot default option Ltype Len in PLOT.

Creating User-Defined Linetypes

In addition to the standard linetypes supplied with Creo Elements/Direct Drafting (see [Figure 11. Linetypes and Corresponding Point Symbols on page 51](#)), you can quickly and easily create your own linetypes through a repeated sequence of dot and dash patterns.

To create a user-defined (custom) linetype:

1. Press **LTYP**.
2. Press **All** in **LINETYPE**.
3. Press **ADD** in **LINE PATTERN**.
4. Enter a name (in apostrophes) for the line pattern you are about to create.
5. Enter the line pattern values in one of the following formats:
 - A sequence of 1s and 0s, in which each 1 denotes a dot and each 0 denotes a gap. Note that the first number of this sequence must not be a 0. For example:
1111011110000
 - A sequence of comma-separated natural numbers, in which the first (third, fifth, ...) number denotes the number of dots and the second (fourth, sixth, ...) number denotes the number of gaps. (Creo Elements/Direct Drafting will convert any sequence of 1s and 0s to this notation.) For example:
4, 1, 4, 4

Note that both of these examples produce the same linetype.

The following figure gives you a visual impression of the new linetype defined in the two examples above. Note that the newly defined linetype pattern is appended to the list of built-in linetypes.

Figure 12. Eight Built-In Linetypes Plus a User-Defined Linetype

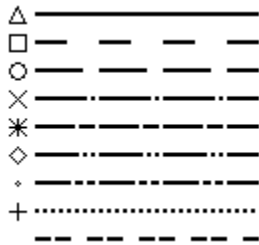

To apply your new linetype, follow the instructions in [Changing the Linetype on page 51](#).

Exporting User-Defined Linetypes

Any user-defined linetypes are saved to your current MI file. By sending this MI file to another Creo Elements/Direct Drafting user, you can make your user-defined linetypes available to this user.

These additional linetypes will be listed as "imported" linetypes in the linetype menu.

Editing User-Defined Linetypes

To edit a user-defined (custom) linetype:

1. Press **LTYP**.
2. Press **All** in **LINETYPE**.
3. Press **EDIT** in **LINE PATTERN**.
4. Edit the linetype as appropriate. Refer to [Creating User-Defined Linetypes on page 52](#) for guidance.

Deleting User-Defined Linetypes

To delete a user-defined (custom) linetype:

1. Press **LTYP**.
2. Press **All** in **LINETYPE**.
3. Press **DELETE** in **LINE PATTERN**.
4. Select the user-defined linetype to be deleted.

Changing Pensize and Linesize

The thickness of elements can be set by setting the pensize or linesize properties.

 **Note**

The **PENSIZE** command replaces the **LINWIDTH** command.)

Figure 13. Scaling with Pensize and Linesize

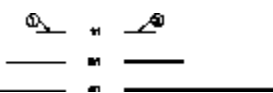

Item	Description
1	Pensize: The line is non-scalable. This means that if you create a line having a pensize of 1 mm, and then scale it by a factor of 2, the thickness of the line remains 1 mm.
2	Linesize: The line is scalable. In this case, if you create a line having a linesize of 1 mm, and then scale it by a factor of 2, the new thickness of the line is 2 mm.

[Figure 14. Difference between Pensize and Linesize on page 54](#) shows one benefit of specifying pensize and linesize for specific elements.

Figure 14. Difference between Pensize and Linesize

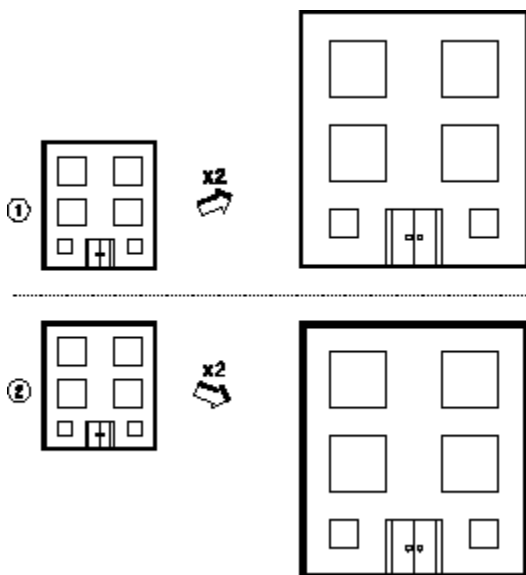

Item	Description
1	All geometry elements are drawn with the property pensize. When scaled, all lines remain the same size (thickness).
2	The outline of the building is drawn with the property linesize. All other elements are drawn with the property pensize. When scaled, the thickness of the outline increases but the other elements remain the same thickness.

To set the pensize of a particular group of elements:

1. Press **CREATE**.
2. Pick an option in **CREATE**.
3. Pick **P-Size** in **LINETYPE**.
4. Enter a value (for example 1).
5. Draw an element.

This new pensize value is displayed in the field adjacent to P-Size. Creo Elements/Direct Drafting retains this information.

When you return to the **CREATE** menu and select a command, all lines are drawn in the specified size.

To set the linesize of a particular group of elements:

1. Enter **LINESIZE** on the command line or pick L-Size in **LINETYPE**.
2. Enter a value (for example, 3).
3. Draw the element.

This new linesize value is displayed in the field adjacent to L-Size. Creo Elements/Direct Drafting retains this information.

Figure 15. Lines Drawn with Different Sizes on page 55 shows some sample sizes. The ends of lines are rounded so that when more than one line intersects, a rounded end is formed. Otherwise, the line end would appear stepped.

Figure 15. Lines Drawn with Different Sizes

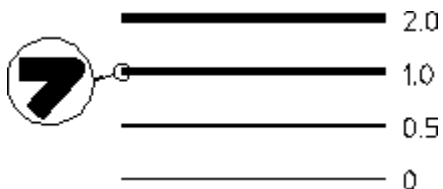

When using the pensize and linesize property, take note of the following:

- Pensize and linesize are mutually exclusive: Specifying linesize resets pensize to 0, and specifying pensize resets linesize to 0.

-
- Linesize supports HP-GL/2 and PostScript.

Changing the Pensize and Linesize of Existing Elements

To change the pensize of an existing element:

1. Pick **Chg PS** in **LINETYPE**.
2. Enter a value (for example, 1).
3. Select the element.

To change the linesize of an existing element:

- Enter `CHANGE_LINESIZE` on the command line and select the element or
- Pick **Chg LS** in **LINETYPE** and select the element.

Changing Color

Color functions are used for geometry, construction geometry, text, hatching and dimensioning.

To change the color of a particular group of elements (for example, dimensions), specify a color after you have chosen a command within the DIMENSION menus.

This new color will then be displayed in the System Status Line. Creo Elements/Direct Drafting will retain this information and all future dimensions will continue to be drawn in the specified color.

Changing the Color of Existing Elements

To change the color of existing elements:

1. Press **ChgCol** in the **COLOR** block.
2. Press the required color.
3. Identify the element to be changed.

The colors available for you to use are as follows:

- Black and White.
- The six basic colors:
Red, Yellow, Green, Cyan, Magenta and Blue.
- `RGB_COLOR` (refer to [Using the RGB Color System on page 60](#))
- `HSL_COLOR` (refer to [The HSL_COLOR System on page 60](#))

 **Note**

The colors you choose are linked to the pen transformation so that you can allocate plotter pens to the colors displayed on the screen. (See PLOT_TRANSFORMATION in the online Help.)

Changing Color Settings with the RGB and HSL Color Menus

With the RGB and HSL Menus, you can mix your own color from the palette and store it. To display the color menus, press **RGB** or **HSL** in **COLOR**.

Figure 16. RGB and HSL Color Menus

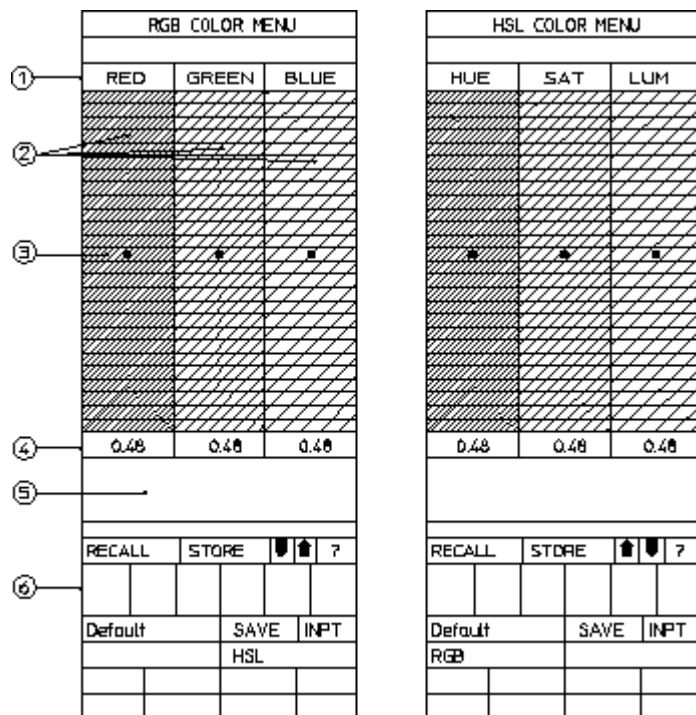

- 1 Field headings
- 2 Marker fields
- 3 Markers (current settings)
- 4 Current numerical value of setting
- 5 Sample of color
- 6 Current palette (up to six colors)

Each cell increases in steps of 0.04. You can increase the intensities by picking cells or picking the current intensity value and entering the desired value on the command line. When you do this, the change is permanent. For example, if you

pick the cell with value 0.72 and enter 0.738, that cell is reassigned to the new value until it is overwritten. If the new value is less than or greater than the adjacent cell, the marker jumps to the appropriate cell along with its new value.

To specify a color based on the RGB system, press **RGB** in **COLOR**. Creo Elements/Direct Drafting displays the RGB COLOR MENU and you can specify the red, green, and blue intensities.

Example

With the **RGB COLOR MENU** displayed;

1. Pick
2. Position the markers at the desired intensity (simply pick a cell)
3. Draw an element

All elements are now drawn with the same color.

Options	Description
RECALL	<p>Recalls a color from the current color palette (not from a saved file):</p> <ol style="list-style-type: none"> 1. Pick RECALL 2. Pick a color from the color palette (boxes 1 to 6 in Figure 17. How the Up-arrow and Down-arrow Functions Work on page 59) 3. Pick the sample-color box 4. Draw an element.
STORE	<p>Stores colors in the current color palette:</p> <ol style="list-style-type: none"> 1. Position the markers at the desired intensity 2. Pick STORE 3. Pick a box in the color palette (boxes 1 to 6 in Figure 17. How the Up-arrow and Down-arrow Functions Work on page 59) <p>You can repeat the previous steps until all boxes are filled and then save this color scheme to a file by picking SAVE</p>
Up-arrow	<p>Displays the upper six colors in the color palette (see Figure 17. How the Up-arrow and Down-arrow Functions Work on page 59)</p>
Down-arrow	<p>Displays the lower six colors in the color palette (see Figure 17. How the Up-arrow and Down-arrow Functions Work on page 59)</p>
?	<p>Inquires an element's colors.</p> <ol style="list-style-type: none"> 1. Pick ? 2. Pick an element.

Options	Description
	Creo Elements/Direct Drafting places the element's color properties in the selection window
Default	Returns the RGB and HSL color settings to default.
SAVE	Saves the color palette to a file for later use.
INPT	Inputs a file that was saved with the SAVE option.

The ? function is also useful if you want to inquire the other color system's settings. For example, suppose you create a line specifying HSL colors and want to know what the equivalent is in the RGB system. In the RGB COLOR MENU, pick ? and identify the element. You get the HSL-equivalent of the RGB color.

Figure 17. How the Up-arrow and Down-arrow Functions Work on page 59 shows what happens when the Up-arrow and Down-arrow arrows are picked. With the color markers positioned as shown, the sample-color box shows the color magenta (M). Creo Elements/Direct Drafting now uses this color as a reference to create an upper and lower range of colors which are displayed in the color palette-boxes 1 to 6. (You can think of these as six darker and six lighter shades of magenta.) Use the Up-arrow and Down-arrow arrows to toggle between the ranges.

Figure 17. How the Up-arrow and Down-arrow Functions Work

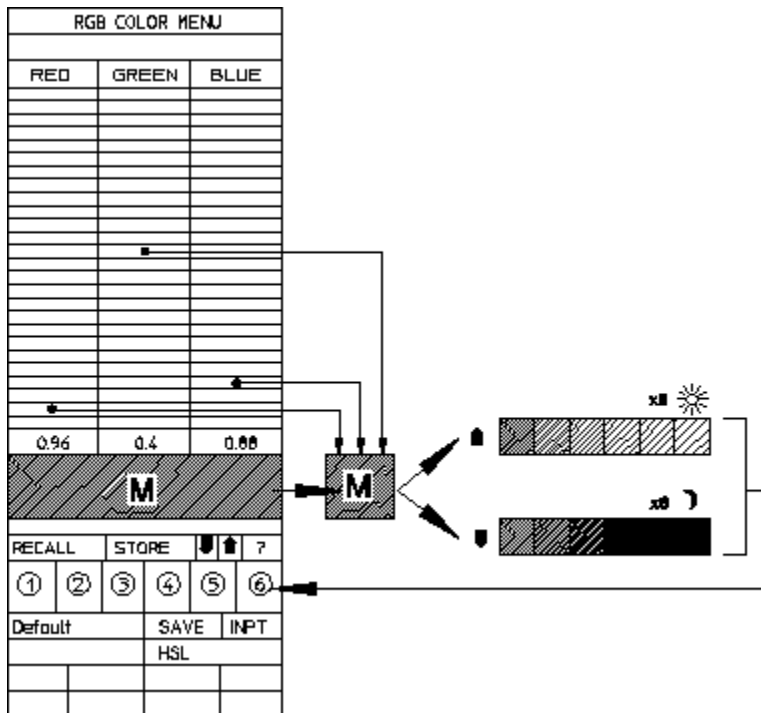

You can now recall colors as described previously.

The advantage of this method is to let Creo Elements/Direct Drafting generate a group of colors based on a reference color.

Although the description is for the RGB system, the principles also apply to the HSL system.

The RGB_COLOR System

The RGB (Red, Green, Blue) model implemented with Creo Elements/Direct Drafting can be thought of as a color system that mixes three different light sources. These three light sources are the additive primaries, namely red, green, and blue. To obtain the various colors available, specify the intensity of each of the three colors (the range is 0 to 1).

The origin of the color cube is black. By increasing the intensities of the three primary colors you will gradually move towards the color white, which lies on the opposite diagonal of the cube, at 1,1,1.

The diagonal of the cube, from 0,0,0 to 1,1,1 represents the gray shades of the spectrum. Therefore by inputting the same intensity for each of the primary colors you will obtain various shades of gray.

Using the RGB Color System

To specify a particular color, enter RGB_COLOR and press [Enter]. Creo Elements/Direct Drafting will prompt you to specify the red, green, and blue intensities in succession.

Example

1. Enter RGB_COLOR [Enter].
2. Enter the Red Intensity 0.5 [Enter].
3. Enter the Green Intensity 0.3 [Enter].
4. Enter the Blue Intensity 0.7 [Enter].

Alternatively you can type:

```
RGB_COLOR 0.5 0.3 0.7 [Enter]
```

[Changing Color Settings with the RGB and HSL Color Menus on page 57](#) tells you how to use the RGB COLOR MENU to set the intensities.

The HSL_COLOR System

The HSL (Hue, Saturation, Luminosity) color model implemented with Creo Elements/Direct Drafting is a system that allows you to select pure hues, and then mix white and black with them to lighten and/or darken them. The three parameters used are:

-
- Hue: the pure color you choose to work with.
 - Saturation: the ratio of the pure color mixed with white.
 - Luminosity: the brightness per unit area.

To obtain the various colors available, specify a value for each of these three parameters (the range is 0 to 1).

The base of the cylinder is a black plane, $L=0$. To move vertically up the cylinder, the luminosity parameter is increased and the brightness of the color will therefore change. White is represented at the center of the top plane of the cylinder, $L=1$, and $S=0$. The center line of the cylinder, and $S=0$, L ranging from 0 to 1 represents the gray shades of the spectrum. The outer edge of the cylinder, $S=1$, represents fully saturated color.

The HSL color cylinder uses a cylindrical coordinate system. A cylindrical coordinate system is one in which a polar coordinate system representing the X-Y plane is combined with a Z axis from a rectangular coordinate system. The coordinates are normalized and range from 0 to 1.

- Hue is the angular coordinate.
- Saturation is the radial coordinate.
- Luminosity is the distance above the polar coordinate plane.

Using the HSL Color System

First, select the hue you want to work with. A large number of color filters are arranged to form a disk. White light is then passed through the selected filter and the desired hue is obtained.

Red is the starting and finishing point and is thus represented by two parametric values, 0 and 1.

Next, you must decide how saturated you want the color to be. This is done by specifying the amount of white light to be mixed with the pure hue already chosen. The value of the second parameter, saturation, also ranges from 0 to 1, 0 representing no color, that is, pure white, and 1 representing fully saturated color.

Finally, you must specify the luminosity or brightness of the color. The value of the luminosity parameter also ranges from 0 to 1.

Example

1. Enter HSL_COLOR [Enter].
2. Enter the hue 0.5 [Enter].
3. Enter the saturation 0.3 [Enter].
4. Enter the luminosity 0.7 [Enter].

Alternatively, you can enter:

HSL_COLOR 0.5, 0.3, 0.7 [Enter].

[Changing Color Settings with the RGB and HSL Color Menus on page 57](#) tells you how to use the HSL COLOR MENU to set the values.

The Dithering Effect

The ability to display the various RGB and HSL colors is dependent on your hardware. The number of colors that can be displayed typically ranges from 2 to 256 according to the hardware.

However, since not all hardware has the ability to display the range of colors the RGB and HSL color system offers, a dithering effect is used to increase the number of shades available. This creates the impression of a larger range of colors than the hardware actually supports.

This dithering effect creates patterns of dots in the available colors. The eye then combines them into a perceived color different from the actual colors used to produce the patterns.

Although dithering can create a larger range of colors for surfaces, the drawing lines and the System Status Line can be displayed only in the range of colors supported by the hardware.

Changing the Catch Mode

The catch mode allows you to select a point on the screen without putting the cursor directly on that point.

The system will catch to a given point only if the point lies within the (imaginary) circle around the edges of the cursor.

Press **CATCH** followed by one of the following options. The system catches to the specified point:

- **RULER/GRID** — ruler/grid point
- **INTERS** — intersection
- **VERTEX** — vertex
- **ELEM** — element
- **CENTER** — center point

RULER/GRID, **INTERS** or **VERTEX** catch modes remain active until you change them.

ELEM or **CENTER** catch modes are active for one catch only, after which the system switches automatically back to **ALL**. The default in **CATCH** is **ALL**. Press **ALL** in **CATCH** and the system will catch using the following order of priority:

1. **VERTEX**

-
2. **INTERS**
 3. **RULER/GRID**
 4. **ELEM**

If the system finds a vertex within the catch range it catches to the closest such vertex; otherwise it searches for intersections and so on. If the system can't find any of these, it uses the given input point.

Press **OFF** to switch catch off completely.

The current catch mode is always displayed in the System Status Line.

 **Note**

By default, Catch mode ELEM is used, when moving elements like geometry or parts via handles. To use a different Catch mode than ELEM, type `MH_USE_CATCH_MODE ON` in the User Input line. Now, the current Catch mode is used to move the elements via handles.

Setting the Catch Range

To alter the catch range:

1. Press **RANGE** to display the current value.
2. Enter the new value (the size in pixels).
3. Press [Enter].

The size of the small cursor will change to cover the new catch range. This allows you to visually check if the catch range is suitable for your purposes.

Measuring Distances

The **MEASURE** functions allow you to obtain values for arc lengths, distances, point coordinates, angles, and areas. These functions are useful if you need to enter a value measured from existing features on the drawing. To illustrate this, consider the following example.

Example

Suppose you want to draw a vertical line starting at 100,100 and of the same length as an existing line drawn at an angle of 40 degrees:

1. Press **CREATE**.
2. Pick Vertical in **LINE**.

-
3. Enter the start point `100, 100` and press `[Enter]`.
 4. Now interrupt the command by pressing **LENGTH** in the **MEASURE** block.
 5. Identify the existing line.
 6. The length will appear in the User Input Line. Press `[Enter]`.
Creo Elements/Direct Drafting automatically returns to the Vertical command.
 7. Press `[Enter]` to obtain a vertical line of equal length to the angled line.

Measure in a loop

In older versions of Drafting, the MEASURE function ended after one execution. You can measure continuously instead, or keep the traditional behavior.

Use the `MULTIPLE_MEASURE` switch to measure in a loop.

`MULTIPLE_MEASURE` does not terminate other commands or functions. In the user input line, each new measurement overwrites the last. `MULTIPLE_MEASURE` works with `MEASURE_ANGLE`, `MEASURE_COORDINATE`, `MEASURE_DISTANCE`, `MEASURE_LENGTH`, and `MEASURE_RADIUS`. `MULTIPLE_MEASURE` does not work with `MEASURE_AREA` or `MEASURE_TANG_ANGLE_AT_POINT`.

Enter `MULTIPLE_MEASURE ON` in the user input line. When you're finished making measurements, type `END` to exit the loop.

Restore traditional measurement behavior with `MULTIPLE_MEASURE OFF`.

Note

- The `RULER FOLLOW` function, described later in this section, is not active during the `MEASURE` function.
- If any of the `MEASURE` functions are used within macros, the resultant measurement will be stored and can be obtained by using the `INQ` function.

Measuring Lengths

Press **LENGTH** to measure the length of any element, (line, circle, arc, fillet, chamfer or spline).

Measuring Distances (Horizontal and Vertical)

Note

This option is dependent on the current catch mode.

Press **Horizontal** and **Vertical** to measure the horizontal or vertical distance between two points.

Displaying Point Coordinates

Note

This option is dependent on the current catch mode.

To display the exact coordinates of any existing point:

1. Press **POINT**.
2. Identify the point.

Measuring Angles

To measure the angle between two lines:

1. Press **ANGLE** in **MEASURE**.
2. Indicate a point on the first line.
3. Indicate a point on the second line.

Similarly, to measure an arc segment angle, indicate the arc start and end points.

The angle between two tangents drawn at an intersection point of two circles can be measured by indicating a point on the first circle and then a point on the second.

Measuring a Radius

To measure the radius of a curved element:

1. Enter `MEASURE_RADIUS`, press `[Enter]`.
2. Indicate the curved element whose radius you want to measure.

Measuring Face Areas

A Single Face

To calculate the area and area properties of a selected face, the face must be completely bounded by elements.

Creo Elements/Direct Drafting calculates and displays the following area properties for a single face:

- Number of holes in the face.
- Density of the face.
- Perimeter length of the face (outer perimeter).
- Area.
- Center of Area (= Center of Mass).
- Principal Axes (of Inertia through the Center of Area).
- Second Moments of Area about principal axes.
- Second Moments of Area about coordinate system axes.
- Product of Second Moment of Area about coordinate system axes.
- Moments of Inertia about principal axes.
- Moments of Inertia about coordinate system axes.
- Product of Moment of Inertia about coordinate system axes.
- Section Moduli (about principal axes).
- Distance from first neutral axis to extreme fiber.
- Distance from second neutral axis to extreme fiber.
- Radii of Gyration.
- Angle between coordinate system and principal axes.

Multiple Faces

If you identify multiple faces, Creo Elements/Direct Drafting uses the density values to calculate the Common Center of Mass. The density must be specified before a face is identified, otherwise the default value (1) or the previous density value is used.

Creo Elements/Direct Drafting calculates and displays the following total values for multiple faces:

- Total Area.
- Center of Area (common).
- Center of Mass (common).

-
- Principal Axes through the (common) Center of Area.
 - Second Moments of Area about (common) Principal Axes.
 - Second Moments of Area about Coordinate System Axes.
 - Product of Second Moment of Area about Coordinate System Axes.
 - Moments of Inertia about (common) Principal Axes.
 - Moments of Inertia about Coordinate System Axes.
 - Product of Moment of Inertia about Coordinate System Axes.
 - Radii of Gyration with respect to the (common) Center of Area.
 - Angle between Coordinate System and (common) Principal Axes.

To display face area properties:

1. Press **Area Prop** in **MEASURE**.

Creo Elements/Direct Drafting prompts you to enter a density (default 1) or identify a face(s).

2. Enter the density value if known, otherwise identify the face(s).

Creo Elements/Direct Drafting prompts for an output option SCREEN, DEL_ _OLD, APPEND, or filename.

3. Enter SCREEN to display the information.

The density value is reset to 1 after using an output option.

4. Press [Ctrl] [D] to return to Creo Elements/Direct Drafting.

 **Note**

Creo Elements/Direct Drafting marks the Center of Area with a (*) on the face (s) you have identified. If you have identified multiple faces then Creo Elements/Direct Drafting also marks the Common Center of Area with a (+) and the Common Center of Mass with a (o).

Example

Figure 18. I - Section Face on page 68 shows an I-section face.

Figure 18. I - Section Face

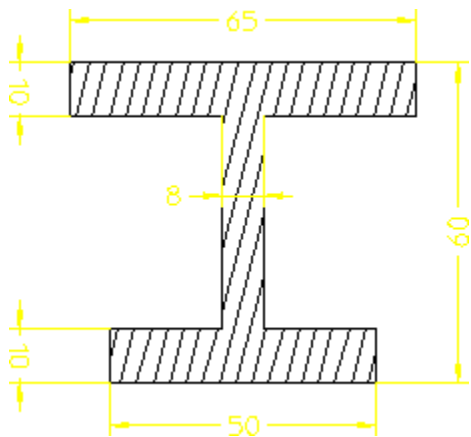
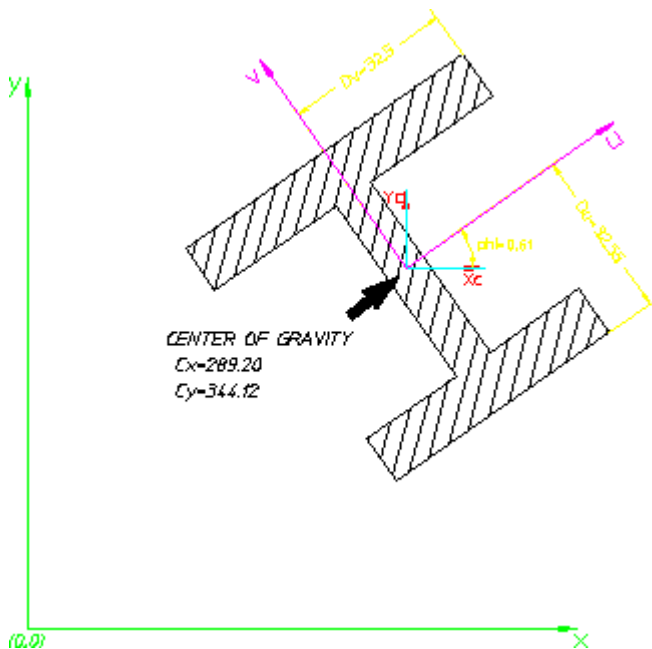

Figure 19 on page 50 is a resultant diagram for the I-section face.

Figure 19. Resultant Diagram for I-Section Face



A listing of the Creo Elements/Direct Drafting output for this single face is given below:

ALL VALUES REFER TO THE FOLLOWING UNITS :
LENGTH = 1 MM
ANGLE = 1 DEG

FACE 1:
NUMBER OF HOLES
noh = 0
DENSITY

```

rho = 1
PERIMETER LENGTH
P = 334
AREA
A = 1470
CENTER OF AREA = CENTER OF MASS
(Cx,Cy) = (289.2011071614633,344.1233317074434)
PRINCIPAL AXES OF INERTIA THROUGH THE CENTER OF AREA
(DIRECTIONS)
u = (0.8191520442890209,0.5735764363510046)
v = (-0.5735764363510046,0.8191520442890209)
SECOND MOMENTS OF AREA (ABOUT PRINCIPAL AXES)
Icu = 761433.6734694783
Icv = 334727.5
SECOND MOMENTS OF AREA (ABOUT COORDINATE SYSTEM AXES)
Ix = 174699726.7554225
Iy = 123421911.6970526
PRODUCT OF SECOND MOMENT OF AREA (ABOUT COORDINATE SYSTEM AXES)
Ixy = 146095161.0177031
MOMENTS OF INERTIA (ABOUT PRINCIPAL AXES)
Jcu = 761433.673469478
Jcv = 334727.5
MOMENTS OF INERTIA (ABOUT COORDINATE SYSTEM AXES)
Jx = 174699726.755422
Jy = 123421911.697053
PRODUCT OF MOMENT OF INERTIA (ABOUT COORDINATE SYSTEM AXES)
Jxy = 146095161.017703
SECTION MODULI ABOUT PRINCIPAL AXES
Zcu = 23392.00626959447
Zcv = 10299.30769231674
DISTANCE FROM NEUTRAL AXIS u TO EXTREME FIBER
Du = 32.55102040816436
DISTANCE FROM NEUTRAL AXIS v TO EXTREME FIBER
Dv = 32.5
RADIOI OF GYRATION WITH RESPECT TO THE CENTER OF AREA
Rcu = 22.7592199074477
Rcv = 15.08992320434836
ANGLE BETWEEN COORDINATE SYSTEM AND PRINCIPLE AXES
phi = 35

```

Using the Calculator

Creo Elements/Direct Drafting has its own calculator to let you calculate values that can be directly entered into the command line or the drawing itself. The calculator's logic system is based on the method called RPN (Reverse Polish Notation).

The CALCULATOR menu can be found in the **MEASURE** command block and works interactively with Creo Elements/Direct Drafting. For example, you can interrupt a pick sequence, make a calculation, and then use the answer for the next pick.

The calculator functions with integers only and cannot interpret text characters. Creo Elements/Direct Drafting's calculator is useful for:

- Numeric calculations
- Links computations with Creo Elements/Direct Drafting
- System inquiries

Figure 20. CALCULATOR Menu

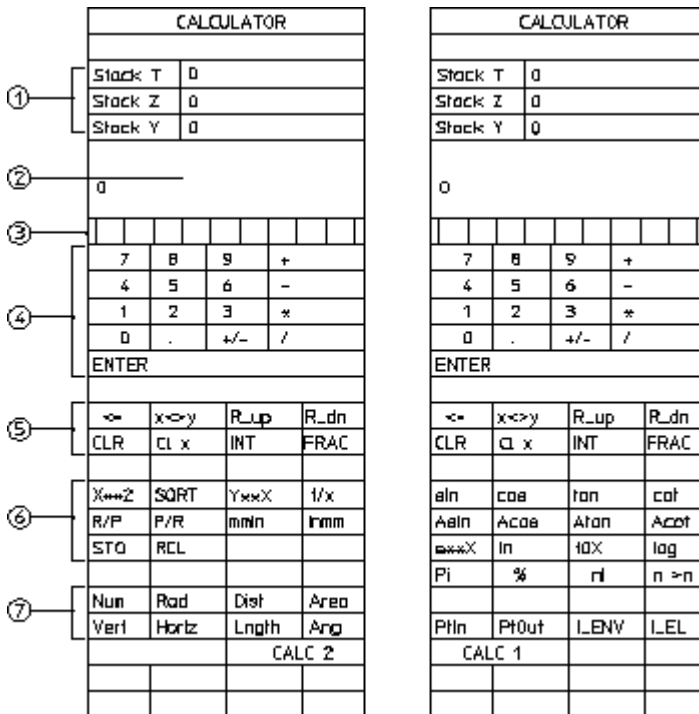

The menu areas are:

- 1 Stack fields
- 2 Data field (referred to as the X-stack)
- 3 Memory registers
- 4 Data-entry keys
- 5 Mathematical functions
- 6 Mathematical functions
- 7 Numerical measurements

The functions have the following meaning:

<=	Deletes last integer
x<>y	Swaps the stack values

R_up	Rolls up the stack values
R_dn	Rolls down the stack values
CLR	Clears all the stacks of entries
Cl x	Clears the X-stack only
INT	Converts value to an integer (no rounding-up)
FRAC	Removes integer part
X**2	x^2
SQRT	Square root of value
Y**X	y^x (Y-stack value to power of X-stack value)
1/x	Reciprocal of value in X-stack
R/P	Rectangular/polar coordinate conversion
P/R	Polar/rectangular coordinate conversion
mmIn	Converts mm to inches
Inmm	Converts inches to mm
STO	Stores the X-stack value in a register. Select registers by: <ul style="list-style-type: none"> • Pick register, or • Pick a calculator key 1 to 9, or • Enter a value from 1 to 1 in the command line (pick CALCULATOR to update the registers)
RCL	Recalls a value stored in the register

The following functions retrieve data from the drawing:

Num	Puts a value in the X-stack (after pressing [Enter])
Rad	Determines radius of a circle and places it in the X-stack
Dist	Calculates the distance between two points
Area	Calculates the area below a curved element and places the calculated value in the X-stack
Vert	Calculates the vertical distance between two points
Horiz	Calculates the horizontal distance between two points
Lngh	Calculates the length of an element (straight lines and curved lines)
Ang	Calculates the angle between two lines

The second calculator menu contains the following:

Trigonometric Functions:	sin (sine) cos (cosine) tan (tangent) cot (cotangent) Asin (arc sine) Acos (arc cosine) Atan (arc tangent) Acot (arc cotangent)
e**X	e ^x (natural antilog)
ln	log__e__ (natural log)
10X	10 ^x (common antilog)
log	log__10__ (common log)
Pi	PI (3.14159265358979)
%	Calculates the percentage of the Y-stack value
n!	Factorial
n > n	Converts base-n systems (where n can be between 2 and 16). For example, you can convert a base-2 value to a base-16 value.

The bottom fields are:

PtIn	Inputs a point (see following example)
PtOut	Outputs a point (see following example)
I_ENV	INQ_ENV function for inquiring the code/index (value is placed in the X-stack)
I_EL	INQ_ELEM function for inquiring the code/index (value is placed in the X-stack)

Example

Points-In and Points-Out

Figure 21. PtIn and PtOut Functions

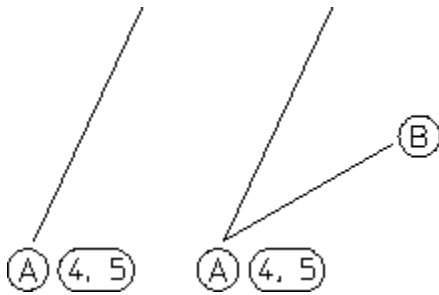

1. Pick PtIn
2. Pick point A

The X and Y-stacks display the coordinates 4 and 5.

1. Pick 2 Pts in LINE
2. Pick PtOut
3. Pick the X-stack value (4)
4. Pick the Y-stack value (5)
5. Pick point B

Using the Ruler/Grid

The ruler simulates the T-square traditionally used with manual drafting methods. When used together with the grid point catch mode, the ruler allows you to draw with the help of a grid. If you prefer you can display a dot or line grid.

To draw using the ruler/grid:

1. Press **Ruler** in **RULER/GRID**.
2. Press **SPACING** in **RULER/GRID**.

SPACING sets the units between each stroke on the ruler or grid.

1. Enter the ruler/grid spacing (for example, 0 . 5).
2. Press **MOVE** in **RULER/GRID**.
3. Identify the start point for the ruler.
4. Begin to draw using the ruler and grid for positional reference.

Drawing a Ruler

Press **Ruler** in **RULER/GRID** to display ruler axes on your drawing.

Dot Grid or Line Grid

The use of a grid is optional; it can be a useful drawing aid for alignment purposes. Press **Dot Grid** or **Line Grid** to display the respective grid type.

Switching the Ruler/Grid Off

Press **OFF** to switch off the ruler, dot grid, or line grid.

Off	All viewports accepted
On	Current viewport only.

Displaying the Origin

Press **ORIGIN** in **RULER/GRID** and the coordinate origin is displayed in the chosen viewport by an axes symbol. If the ruler is active in the chosen viewport, it is turned off.

Setting Cursor Size

You can use either a small cursor or a full screen cursor. A full screen cursor is particularly recommended for use with the ruler. Press **Curs Lg/Sm** to change the cursor from one to the other. The catch range is not affected.

Using Follow On/Off

Normally the ruler will remain in the same position while you draw. Press **Follow On** to make the ruler move automatically to each new point you create.

The ruler is always located at the origin. The origin always tracks the ruler, and the ruler always tracks the origin. Pressing **Follow On** in **RULER/GRID** causes the coordinate system origin to move with the origin of the ruler.

Moving the Ruler

Press **MOVE** and indicate the new origin. The orientation of the ruler axes will remain the same.

Rotating the Ruler/Grid

With Respect to X-axis

To rotate the ruler (or grid) so that the x-axis is at a given angle to the horizontal:

1. Press **Turn Abs** in **RULER/GRID**.

-
2. Enter the angle required.

Through a Given Angle

To rotate the ruler (or grid) through a given angle:

1. Press **Turn Rel** in **RULER/GRID**.
2. Enter the rotation angle required.

A positive value results in counterclockwise rotation.

Setting the Ruler/Grid Spacing

To set the units between each stroke marked on the ruler or grid:

1. Press **SPACING** in **RULER/GRID**.
2. Enter the ruler/grid spacing (for example 0 . 5).

If the divisions are very small, they will not be shown on the screen but they will still be used for catch when in ruler or grid catch mode. Use the **WINDOW** functions if you want an enlarged view. The current spacing is shown in the System Status Line.

Drawing an Isometric Ruler/Grid

Press **Isom Front**, **Isom Top** and **Isom Side** in **RULER/GRID** to redraw the ruler or grid according to the isometric grid required for drawing top, front, or side views.

Resetting the Ruler/Grid

Press **RESET** in **RULER/GRID** to reset the ruler or grid to the default system orientation and origin. It also resets the ruler axes to a mutually orthogonal position.

Placing the Ruler/Grid

To change the orientation of the axes:

1. Press **PLACE** in **RULER/GRID**.
2. Indicate two points that coincide with the new x-axis of the ruler. These two points will often lie on an existing line.

[Figure 22. Ruler Axes on page 76](#) shows the ruler axes.

Figure 22. Ruler Axes

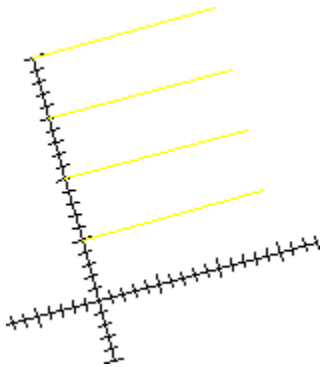

Selecting What is Displayed on Your Screen

This section describes how to use the **SHOW** function block to control exactly what is displayed on your screen. **SHOW** operates in the current viewport.

Before you plot your complete drawing, you are recommended to check what is included by pressing **SHOW ALL**.

You can selectively display:

- Construction lines (geometry)
- Drawing lines (geometry)
- Dimensions
- Layers
- Hatching
- Points (Vertices)
- Text
- Info

Note

The **SHOW** settings are only valid for the current viewport.

Any new viewports created will automatically adopt the settings of the viewport that was active when they were created.

Showing All Features

Press **SHOW, ALL** to display all features of your drawing. It is useful to start with everything displayed, then switch off what is not required.

Showing Points

Press **SHOW POINTS** to display all existing points on the drawing. This is useful if you want to identify a point more accurately, or to check if two lines overlap. Points are displayed in the following colors (by default):

- GREEN — end points
- YELLOW — common end points
- BLUE — single center points
- MAGENTA — multiple center points

Showing Dimensions

This option allows you to turn dimensions on and off as a group. Any dimensions created after the dimensions have been turned off will not be displayed on the screen until the dimensions are turned on again.

Note

It is also possible to use the selection mechanism in conjunction with the **SHOW** functions. First enter **SHOW** and press [Enter], then select the elements you want to work with.

Changing the Layer Color

To change the color of a specified layer.

1. Press **LayerColor** in **SHOW**.
2. Enter the layer number.
3. Press the appropriate color on the **COLOR** block.

Displaying Infos

Press **INFO** in **SHOW** to display elements that have information attached.

Visibility Indicator (DHTC)

The letters D — Dimensions, H — Hatch and T — Text C — Construction Geometry, displayed in the System Status Line indicate the visibility of the different groups of elements.

Dimensions can be treated only as a single entity, either turned on or off. A lowercase letter indicates all are switched off, an uppercase letter indicates all are switched on.

- D — Dimension Geometry
- H — Hatch
- T — Text
- C — Construction Geometry

If any element in one of these groups is turned off, the corresponding letter is shown in lowercase. If all elements of a particular group are being displayed, the corresponding letter is shown in uppercase.

Viewing a Drawing

This section shows how to use the normal and dynamic **WINDOW** functions to see details in your drawing more clearly. You can zoom in on the area concerned, or reposition the drawing on the screen.

WINDOW functions are selected by pressing **WINDOW** to display the WINDOW menu. The **WINDOW** functions operate on either the current viewport (default) or on a viewport you selected. You can use normal or real-time (dynamic) **WINDOW** functions. Both are accessible via a screen menu.

- Note that the left mouse button combined with the [Ctrl] key can be used for panning. The right mouse button combined with the [Ctrl] key can be used for zooming.

Selecting a Viewport

You can select the viewport in which the **WINDOW** functions operate. Press **WINDOW** to display the WINDOW screen menu.

The WINDOW options are:

- Curr Viewp
- Sel Viewp

Current Viewport

If you want the **WINDOW** functions to operate in the current viewport:

1. Press **WINDOW**.
2. Pick **Curr Viewp**.
3. Identify a viewport or enter the viewport number.

Creo Elements/Direct Drafting will use the current viewport for any **WINDOW** functions.

Select Viewport

Sel Viewp is the default option. Creo Elements/Direct Drafting will prompt you to identify the viewport for the **WINDOW** function.

Using Normal Window Functions

This section shows how to control the area of the drawing shown in the current viewport using the normal **WINDOW** functions.

Redrawing

Press **REDRAW** in **WINDOW** to redraw the drawing in the chosen viewport. This is sometimes necessary if you have deleted several elements and traces can still be seen on the screen. The contents of other viewports will not be redrawn.

Fitting a Drawing

Press **FIT** in **WINDOW** to fit the current drawing into the chosen viewport.

Panning Across a Drawing

Panning is a very useful function enabling you to move across the drawing to see those areas not currently displayed.

[Figure 23. Panning Across a Drawing on page 79](#) illustrates the use of panning.

Figure 23. Panning Across a Drawing

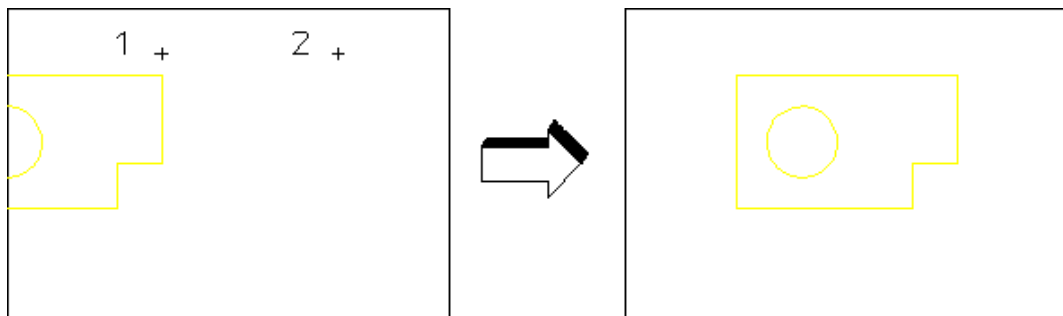

To pan in any direction:

-
1. Press **PAN** in **WINDOW**.
 2. Identify a point on your drawing.
 3. Indicate the new screen position for this point.

Alternatively, press the [Ctrl] key and the left mouse button. Then move the cursor to pan the drawing.

Creating a New Window

To create a new window:

1. Press **NEW** in **WINDOW**.
2. Indicate the bottom left and top right corners of the area you want to enlarge.

Restoring the last View

Press **LAST** in **WINDOW** to return to the previous view.

Zooming In or Out

A window is always zoomed about its center point.

To zoom your window:

1. Press **ZOOM** in **WINDOW**.
2. Enter the zoom factor required.

A number greater than 1 results in a window that covers a smaller area (zooming in). A number less than 1 (>0) or negative (<-1) gives a larger coverage (zooming out).

1. Press [Enter].

Alternatively, press the [Ctrl] key and the right mouse button. Move the mouse towards the screen to zoom in, move the mouse away from the screen to zoom out.

Storing and Recalling Windows

If you are likely to need the same view again, you can store it and recall it as required:

Press **STORE** in **WINDOW** to store the current window coordinates.

Press **RECALL** in **WINDOW** to recall the window that was stored last.

Creating a New Center Point for Your Drawing

Press **CENTER** and indicate the new center point for the display. Your drawing is then repositioned so that this point is in the center of the chosen viewport.

Note

This option uses the current catch mode to identify the specified point.

Using Dynamic Window Functions

Note

Creo Elements/Direct Drafting does not function with a physical knob box. However, you can assign a virtual knob box - this means the pointing device (mouse). The following documentation refers to a virtual knob box.

This section shows how to control the area of the drawing shown in the current viewport using real-time zooming and panning. You can achieve smooth control of these functions by either:

- Using the dynamic option with your mouse.
- Using a the mouse as a virtual knob-box.

Click on the **WINDOW** menu title to display the dynamic WINDOW menu.

Knob Box Controls

The knobs used to control dynamic Pan and Zoom are:

- Lower Left Knob (or key [1] plus the mouse if a virtual knob box is used) – pans the drawing in the X direction.
- Lower Middle Knob (or key [2] plus the mouse if a virtual knob box is used) – pans the drawing in the Y direction.
- Lower Right Knob (or key [3] plus the mouse if a virtual knob box is used) – controls the zoom factor.

Display Lists

This subsection describes display lists and shows how to generate them.

 **Note**

To prevent a decrease in system performance when using display lists we recommend:

- That you only use display lists for fast viewing/windowing on relatively complete drawings.
- You switch the display list off (pick Off in Displ List) if large sections of the drawing are to be changed.
- When display lists are on, do not change the spotlight setting for parts.
- When display lists are on, do not change the show status.
- If you use display lists you should regenerate them regularly to reduce their size to an optimum. To regenerate a display list in the current viewport pick On in Displ List.

A display list is graphical information that is independent of the main drawing data structure.

Very fast redraw, zoom and pan operations are performed using the data in the display list.

Because display lists can consume large amounts of memory you can specify in which viewport they should be generated.

When you generate a display list in a viewport all further Creo Elements/Direct Drafting drawing operations in that viewport are recorded in the display list.

- The display list reflects all existing geometry.
- All new, deleted or changed geometry will cause the display list to grow.

For example, if you create a white line, the white line is appended to the end of the display list. If you later delete this line, an additional line in the background color of the viewport will be drawn on the screen to erase the original white line. This additional line also is appended to the end of the display list.

You can see how much memory is used for the display list and how much is "wasted" on deleting elements. Two numbers are displayed in the lower left corner of the viewport. The left number is the total size of the display list in bytes. The right number is the size in bytes of the part of the display list used for deleting.

Note

The display list numbers only appear in viewports that have display list selected.

When the right number (memory used for deleting) becomes large, meaning that large portions of the display list have been used to remove or change elements, you should regenerate the display list. To generate or regenerate a display list in a viewport:

1. Press the **WINDOW** menu title bar.
2. Pick **On** in **Displ List**.

You can now perform drawing operations. To keep the size of the display list small, regenerate it regularly by picking **On** in **Displ List**.

Redrawing

1. Press **WINDOW**.
2. Pick **Redraw** in **WINDOW** to rapidly redraw your drawing in the current or selected viewport.

Fitting a Drawing

1. Press **WINDOW**.
2. Pick **Fit** in **WINDOW** to rapidly fit your drawing in the current or selected viewport.

Creating a New Window

A dynamic new window gives you immediate feedback on how your drawing will look after you complete the command sequence.

The following example shows you how to create a new window in viewport 1 using viewport 2 as a positional reference. The example assumes that you have a drawing file which you can load and that there are at least two viewports on your screen.

To create a new window:

1. Press **FILE**.
2. Pick **Drw/Part** in **LOAD**.
3. Enter filename (or use the **FBROWSER** command).
4. Press **CURRENT** in **VIEWPORT**.

-
5. Identify viewport 2.
 6. Press **WINDOW**.
 7. Pick Fit in WINDOW.
 8. Press **CURRENT** in **VIEWPORT**.
 9. Identify viewport 1.
 10. Pick **On** in **Displ List**.
 11. Pick **Dyna** in **New**.
 12. Indicate the corner of the new window in viewport 2.
 13. Move the cursor in viewport 2 to change the contents of the window in viewport 1.
 14. Indicate the second point for the new window in viewport 2 when you are satisfied with the view in viewport 1.

Returning to the Last Window

1. Press **WINDOW**.
2. Pick Last in WINDOW to return to the previous view.

Panning Across a Drawing

Dynamic panning gives you immediate feedback on how your drawing will look after you complete the command sequence.

Zooming the Window

Dynamic zoom gives you immediate feedback on how your drawing will look after you complete the command sequence.

The following examples show how to zoom in or out of your drawing in viewport 1 using viewport 2 as a reference.

To zoom the window using a knob box:

1. Press **FILE**.
2. Pick Drw/Part in LOAD.
3. Enter the filename (or use the FBROWSER command).
4. Ensure that viewport 1 is the current viewport.
5. Press **WINDOW**.
6. Pick On in Displ List.
7. Pick Knob Box in WINDOW Pan/Zoom.
8. Pick Dyna in Zoom.

-
9. Turn the lower right knob to zoom the window.

To zoom the window using a stylus:

1. Press **FILE**.
2. Pick Drw/Part in LOAD.
3. Enter the filename (or use the FBROWSER command).
4. Ensure that viewport 1 is the current viewport.
5. Press **WINDOW**.
6. Pick On in Displ List.
7. Pick Dyna in Zoom.
8. Move the cursor in viewport 2.
9. When you have achieved the required zoom in viewport 1, pick that point in viewport 2.

Storing and Recalling Windows

If you are likely to need the same view again, you can store it and recall it as required:

1. Press **WINDOW**.
2. Pick Store in WINDOW to store the coordinates of the selected window.
3. Pick Recall in WINDOW to recall the window that was previously stored.

Creating a New Center Point for Your Drawing

Dynamic center gives you immediate feedback on how your drawing will look after completion of this command. This example assumes the Creo Elements/Direct Drafting default set up of viewport 1 and viewport 2 displayed on your screen.

To create a new center point for your drawing:

1. Press **WINDOW**.
2. Pick Sel Viewp and identify viewport 1.
3. Pick On in Displ List.
4. Pick Dyna in Center.
5. Indicate a new center point for the drawing by moving the cursor in viewport 2.

Creo Elements/Direct Drafting changes the center point in viewport 1 in relation to the position of the cursor in viewport 2.

6. Indicate the final position in viewport 2 for the drawing center point.

Creo Elements/Direct Drafting redraws the drawing with the center point you have indicated.

The Magnifying Glass Effect

The following example illustrates the use of dynamic center. Details on a zoomed-in drawing in viewport 1 are viewed, and viewport 2 is used as a positional reference displaying the entire drawing.

The view in viewport 1 can be imagined as the view you would see if you were examining your drawing with a magnifying glass. To achieve this effect you must zoom in to the drawing displayed in viewport 1 until you can see the required level of detail.

- Viewport 1 — contains a magnified view showing the required level of detail.
- Viewport 2 — contains the entire drawing and is used as a positional reference for the magnifying glass.

First load a drawing:

1. Press **FILE**.
2. Pick Drw/Part in LOAD and load your drawing.
Zoom in to the required level.
3. Press **CURRENT** in **VIEWPORT**.
4. Identify viewport 1.
5. Press **WINDOW**.
6. Pick On in Displ List.
7. Pick Zoom in WINDOW.
8. Pick the required window size or enter the zoom factor.

To display the entire drawing in the reference viewport, fit the view in viewport 2.

9. Press **CURRENT** in **VIEWPORT**.
10. Identify viewport 2.
11. Pick Fit in WINDOW.
Make viewport 1 active.
12. Press **CURRENT** in **VIEWPORT**.
13. Identify viewport 1.
14. Pick Dyna in Center.
15. Examine the zoomed drawing in viewport 1 while moving the cursor (as a positional reference) in viewport 2. See [Figure 24. Using Viewport 2 as a](#)

Reference on page 87 and Figure 25. Viewing Piston Assembly Detail in Viewport 1 on page 88.

Figure 24. Using Viewport 2 as a Reference

Position the cursor box over the required area.

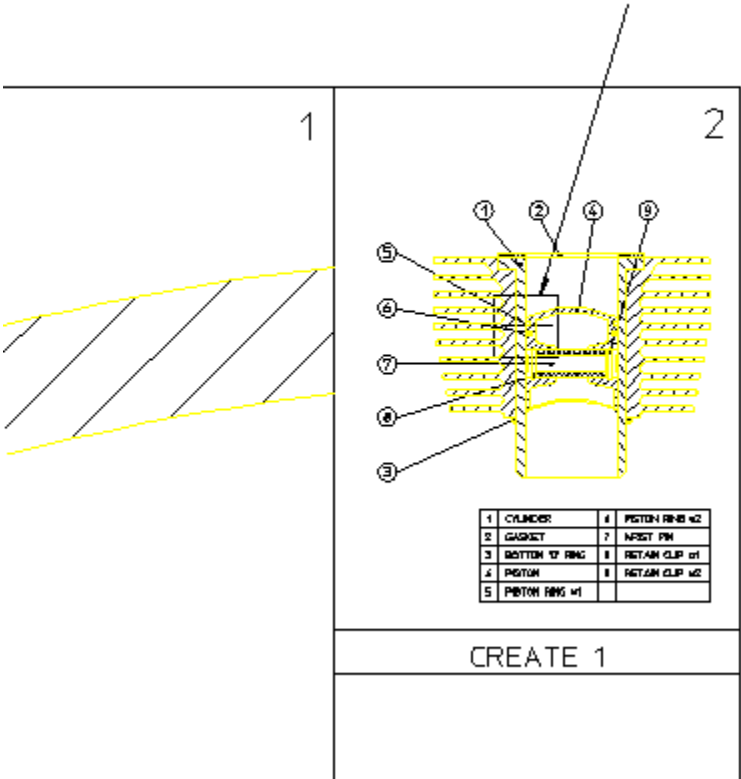
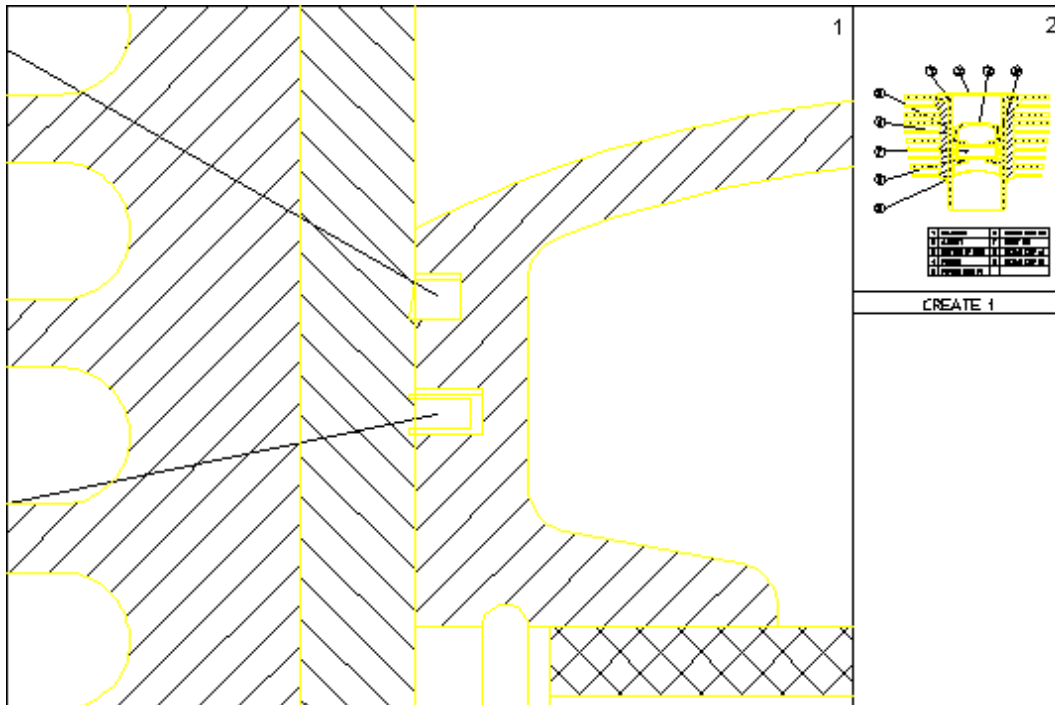

Figure 25. Viewing Piston Assembly Detail in Viewport 1



Using Viewports to Display Several Views

You can divide the drawing area of the screen so that more than one view can be displayed. This is a very useful feature when you want to work on a detail drawing. The changes made to the detail are automatically repeated in the main drawing. Each division of the screen is called a viewport.

Viewports can be overlapped with other viewports, menus, and programmable tables. All overlapping viewports are permanently updated during your drawing session.

Creating a Viewport

To create a new viewport:

1. Press **CREATE** in **VIEWPORT**.

Creo Elements/Direct Drafting will prompt you to input the desired background color, the border width, and the corners of the new viewport. If you do not specify a background color, Creo Elements/Direct Drafting will default to black.

2. Press the appropriate color on the **COLOR** block.
3. Indicate the bottom left and top right corners of the required viewport.

If a viewport is partially or totally covered by other viewports, it is made inactive. Its visual contents will not be updated by any subsequent operations unless it is made the **CURRENT** viewport or you enter `NEW_SCREEN` and press `[Enter]`.

Making a Viewport Current

The current viewport is the one that is currently active, fully visible and up-to-date. The viewport number is displayed in inverse video in the top right corner.

To change the current viewport:

1. Press **CURRENT** in **VIEWPORT**.
2. Identify the viewport required or enter the viewport number.
3. Press `[Enter]`.

Deleting Viewports

To delete a viewport:

1. Press **DELETE** in **VIEWPORT**.
2. Identify the viewport to be deleted or enter the viewport number, or press **ALL** to delete all viewports.
3. Press `[Enter]`.

Using the Entire Screen

Press **Large** in **VIEWPORT** to display your viewport using the whole screen area, including the menu area.

Press **Large** again to return to the normal screen and menu.

Note

To avoid problems recovering your original view, do not change viewports when displaying a full screen view. First, return to the original display by pressing **LARGE/SMALL** in **VIEWPORT**.

Redrawing All Areas

Press **Redraw** in **VIEWPORT** to redraw and update all areas of the screen, that is all viewports, active and inactive, and the menu area.

Changing the Viewport Size

To change the size and position of an existing viewport:

1. Press **CURRENT** in **VIEWPORT**.
2. Identify the viewport you intend to work on.
3. Enter `CHANGE_VIEWPORT_SIZE`.
4. Indicate the new corner points for the viewport.

Changing the Viewport Color

To change the background color of an existing viewport:

1. Press **CURRENT** in **VIEWPORT**.
2. Identify the viewport you intend to work on.
3. Enter `CHANGE_VIEWPORT_COLOR`.
4. Press the required color on the **COLOR** block.

Defining Viewport Settings

To define the viewport settings:

1. Click **VIEWPORT**.
The **VIEWPORT** menu opens.
2. In the **VIEWPORT** menu, click **Set**.
3. Specify the color for viewport background, border, text, and cursor.
4. Specify the border width.
5. Toggle **Invert Col** or **Off**.

When **Invert Col** is **Off**, the elements are not visible, if the element color and the viewport background color are same.

Note

The default setting for **Invert Col** is **On**.

Viewport Example

A common application using viewports is identifying two (or more) widely separated points on a large and complex drawing. Refer to [Figure 26. Joining Two Widely Spaced Points Using Viewports on page 91](#).

Figure 26. Joining Two Widely Spaced Points Using Viewports

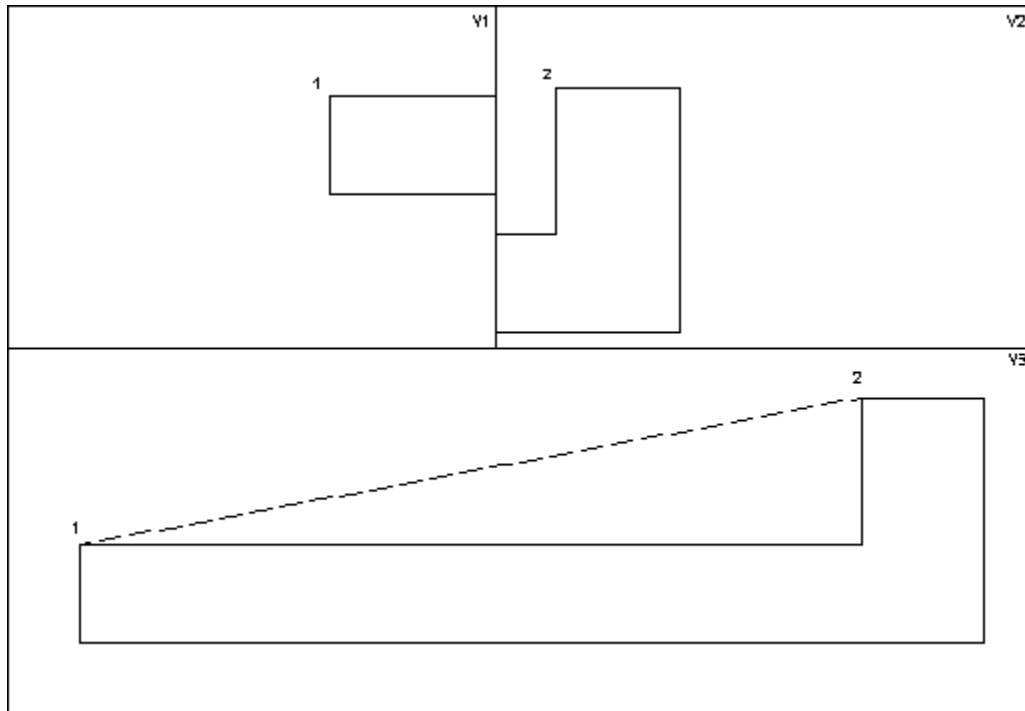

To draw a line between points 1 and 2 in [Figure 26. Joining Two Widely Spaced Points Using Viewports on page 91](#):

1. Create the three viewports (V1, V2 and V3).
2. Make V1 the active viewport.
3. Window into point 1 in V1.
4. Make V2 active.
5. Window into point 2 in V2.
6. Press **CREATE**.
7. Pick 2 Pts in LINE.
8. Identify point 1 in V1 and point 2 in V2.

Creo Elements/Direct Drafting will now draw a line between points 1 and 2.

Creating an Edit Port

The edit port is a rectangular area of the screen you can use to display and edit files. By default Creo Elements/Direct Drafting uses the entire screen to display files you are editing. When you edit a file, Creo Elements/Direct Drafting clears the screen and displays the contents of the file.

You can use a customized edit port (not a full screen) to edit files and see your drawing or menus at the same time (depending upon where you position the edit port).

To change the color, size, inner and outer border width, and location of the edit port:

1. Enter `EDIT_PORT`.
Creo Elements/Direct Drafting prompts for the background, foreground, and cursor color.
2. Enter the border widths or press `[Enter]` to use the default border widths.
Creo Elements/Direct Drafting prompts for the lower left and upper right corner of the edit port.
3. Indicate the lower left corner and the upper right corner of the edit port.
Creo Elements/Direct Drafting creates the specified edit port.
4. Enter `EDIT_FILE 'filename'`
The edit port containing the file you wish to edit will appear. You can now make any changes required.
5. Press `[Ctrl] [D]` to write any changes you have made and close the edit port.

 **Note**

If your edit port is smaller than the width of the text, use the keys arrow (`[^]` `[v]` `[<]` `[>]`) to move around the text.

Using Properties to Change Elements and Text

Line geometry, text and hatch have associated properties. The current settings of all system properties can be stored using the `SAVE ENV` command and accessed using the `EDIT ENV` command, both of which are found in the `SETUP` menu.

Line geometry properties are:

- Color
- Linetype
- Pensize and Linesize

Text properties are:

-
- Font
 - Adjust
 - Angle
 - Fill
 - Frame
 - Linespace
 - Ratio
 - Size
 - Slant

Hatch properties are:

- Pattern
- Angle
- Distance
- Reference Point

Getting and Putting Properties

It is possible to retrieve properties (of **TEXT**, for example) and use them either in subsequent work or to change existing properties.



Note

You cannot change DIMENSION properties using GET and PUT.

For example:

1. Press **GET** in **PROP**.
2. Identify a block of text.

All properties of that text will be retrieved. Any further text entered will now have these properties.

To change the properties of an existing text block to those of another:

1. Press **GET** in **PROP**.
2. Identify the text whose properties are to be retrieved.
3. Press **PUT** in **PROP**.
4. Identify the text whose properties are to be changed.

5

Using Creo Elements/Direct Drafting's Copilot Functionality

Introduction.....	95
Setting the Cursor Delay-Time.....	97
Setting Snap Values	97
Working with Geometry.....	97
Offsetting Elements	99
Example: Slotted Plate.....	100

Introduction

The Copilot functionality lets you view an element's attributes (angles and dimensions) before you fix the position. This dynamic feedback lets you create designs quickly and minimizes the need for construction geometry.

The Copilot functionality can be toggled on or off via the SETUP 1 menu. When copilot functionality is active, you can set the snapping distances and angles.

An additional feature of copilot functionality is being able to offset elements. This is done with the OFFSET option which can be found the **CREATE 1** menu (only when the COPILOT command is switched on). See [Offsetting Elements on page 99](#) later in this chapter for examples about offsetting elements.

The following shows the on-screen feedback that you get when creating geometry.

Figure 27. Copilot Functionality: Typical Feedback

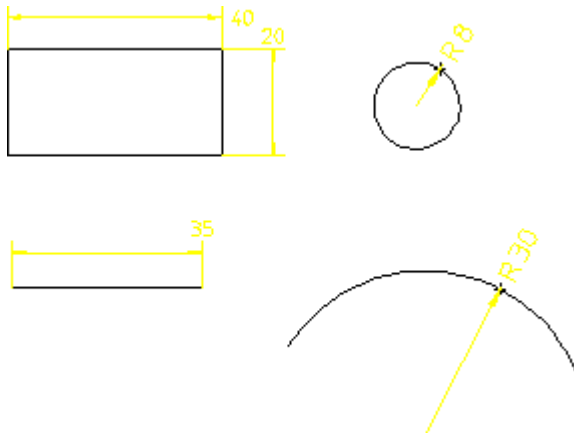

You can also enter values using the keyboard as usual if you need greater precision over size and positioning.

These features apply to the **CREATE** and **MODIFY** menus, and to construction geometry.

The magenta box over the cursor indicates that you are in copilot-mode and about to pick a start-point. Depending on the type of geometry, the line color changes:

Green	Cursor position is coincident with construction geometry
Blue	Cursor position is coincident with existing elements.

When creating a drawing, Creo Elements/Direct Drafting gives you feedback on the status line.

Figure 28. Geometry Feedback on the Status Line

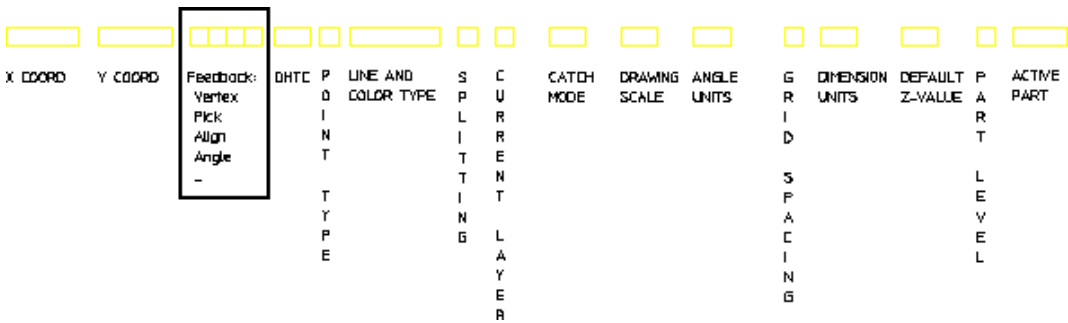

The meaning of the feedback text is as follows:

Align	Cursor position is aligned with intersecting geometry.
Angle	Indicates an angle between the existing line and the new line.
Center	Cursor position is at the center of an element. The center of the line is its midpoint.
Flip	Indicates when the direction of an angle reverses. For example, when creating an arc using Cen R Angs, the center, radius, and one end of the arc are defined. Picking the same end point flips the arc in the opposite direction.
Grid	Indicates that the new element is caught to a grid point.
Int	Cursor position is at an intersection point of construction geometry.
Length	Indicates the length of a line is used. For example, when defining a perpendicular line, Length may be used once the slope is known.
Offset	Indicates that an offset from two elements will be used.
On	Indicates that the cursor will be caught to an element.
Perpend	Indicates the geometry is perpendicular.
Pick	Indicates that a simple pick will occur (cursor is not intersecting with other geometry).
Rel HV	Indicates that relative horizontal vertical distances will be used. For example, the second point of a rectangle can be defined with horizontal and vertical distances relative to the first point.
Slope	Indicates that you are about to define a slope.
Tangent	Indicates that the cursor will be caught to a circular element.
Vertex	Indicates that the cursor will be caught to a vertex.

Setting the Cursor Delay-Time

You can use the command `UA_SET_CATCH_DELAY` to set the amount of time that the cursor must be motionless before Copilot catch information is displayed. A catch delay avoids feedback flashing and jumping when the cursor is moved across a complicated model. A catch delay also improves performance with large models, because the cursor will not pause as it is being moved about the screen.

The delay is a positive number of seconds.

Setting Snap Values

When you switch the COPILOT command on, Creo Elements/Direct Drafting displays the current snapping values:

Snap Dist	Sets the distance that the cursor snaps to.
Snap Ang	Sets the angle that the cursor snaps to.

For example, if the Snap Dist value is set to 1 mm and the Snap Ang to 15°, specifying lengths is restricted to multiples of 1 mm and angles to multiples of 15°. This means that movement of the cursor over empty areas occurs in increments and not as a smooth action.

To change the current value, pick the command and enter the new value.

Working with Geometry

Horizontal and Vertical Construction Geometry

1. Press the horizontal construction line in CONSTRUCT.
2. Pick a point on the screen to place the line.
3. Pick parallel construction line in CONSTRUCT.
4. Pick the first line and drag the cursor over the screen.

Creo Elements/Direct Drafting displays the distance between the two construction lines.

5. Pick the desired point.

Creating vertical construction geometry is similar to the above.

Angular Construction Geometry

1. Press the angle construction line in CONSTRUCT.
2. Pick a point on the screen to fix a point.

-
3. Drag the cursor over the screen and watch how Creo Elements/Direct Drafting displays the angle.
 4. Move the cursor in a circular direction until Creo Elements/Direct Drafting displays the required angle.
 5. Pick the desired point.

The default setting for angle increments is 15° but this can be modified in the setup file.

Circular Construction Geometry

1. Press the center and radius construction in CONSTRUCT.
2. Pick a point on the screen to fix the center.
3. Drag the cursor over the screen and watch how Creo Elements/Direct Drafting displays the radius.
4. Move the cursor in a circular direction until Creo Elements/Direct Drafting displays the required angle.
5. Pick the desired point.

Drawing Elements

To draw horizontal and vertical lines:

1. Press **CREATE 1**
2. Pick Horizontal or Vertical
3. Indicate the begin point of the line.
4. Drag the cursor over the screen.
5. Pick the desired point.

To draw a line with a given length and angle:

1. Press **CREATE 1**.
2. Pick Ang & Len.
3. Indicate the start point of the line.
4. Move the cursor and pick a point to specify the angle. You now have a number of ways to specify the length:
 - Move the cursor along the direction of the line and pick a point. This gives the absolute length of the line.
 - Move the cursor along the horizontal. This gives the horizontal distance.
 - Move the cursor along the vertical. This gives the vertical distance.

-
- Move the cursor to a linear or circular element. The second point is on the element.
 - Move the cursor to an endpoint or intersection point.

Offsetting Elements

Certain construction geometry and drawing elements can be offset to other elements. You do this by first picking a command and then pick **OFFSET** in **CREATE 1** (or enter **OFFSET** on the command line). Pick the first and second elements to define the offset point and then pick the point.

You can specify an offset for the element types created with the commands:

- POINT
- 2 Pts
- Polygon
- Horizontal
- Vertical
- Ang & Len
- Rectangle
- Cen & Pt/R
- CIRCLE commands
- ARC commands

You can also define an offset with the construction-geometry center-and-radius.

Offsetting text is done by first entering the text string and then entering **OFFSET** on the command line. You then pick the elements that the text is offset from.

To offset a hole in a plate:

1. Press **CREATE 1**
2. Pick Rectangle in .
3. Pick the begin point.
4. Drag the cursor to define a rectangle (about 300 mm x 150 mm).
5. Pick the end point.
6. Pick Cen & Pt/R in CIRCLE.
7. Pick **OFFSET**.
8. Pick point 1.
9. Pick point 2.
10. Drag the cursor to point 3 (about 70 mm x 45 mm).

11. Pick the point to fix the center.
12. Drag the cursor and pick the radius (about 18 mm).

Figure 29. Creating an Offset Circle

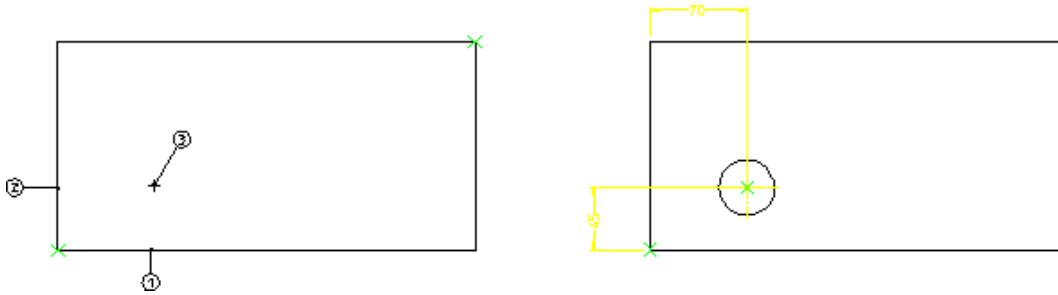

Example: Slotted Plate

Suppose you want to create an engineering drawing from a sketch made at a design meeting. With the copilot functionality, you can quickly turn a sketch into an engineering design without the need for unnecessary construction geometry.

Figure 30. Design Sketch

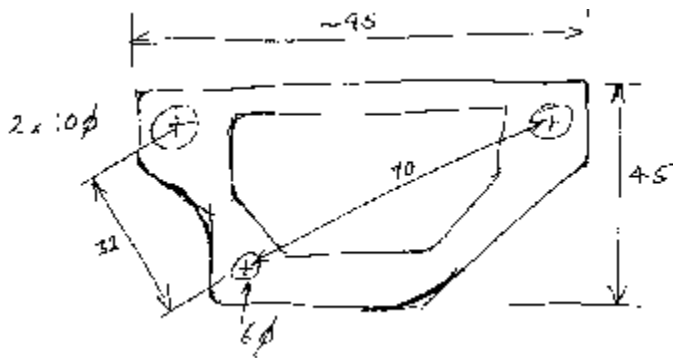
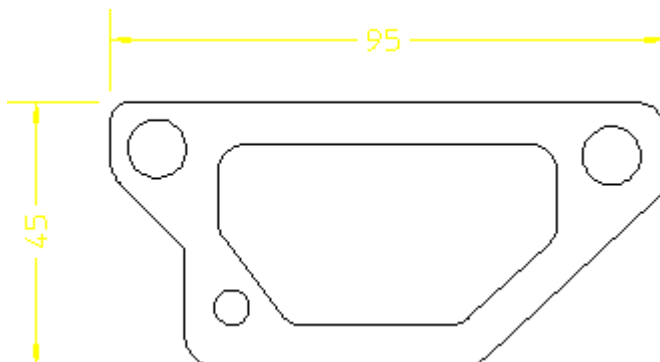

Figure 31. Design Reality



The following example illustrates how to construct the plate with the minimum of construction geometry. As you draw, you will notice that line colors may change as you intersect with existing geometry and the status line gives feedback on your current activity. During certain actions, Creo Elements/Direct Drafting displays negative values. Ignore these for this example.

1. Pick Horizontal and draw a horizontal line of length 50 mm (line 1 in [Figure 32. Slotted Plate - 1 on page 102](#))
2. Pick Vertical and draw a vertical line of length 20 mm (line 2)
3. Pick Ang & Len and pick identify point A
4. Move the cursor in an arc and pick an angle of 135°
5. Drag the cursor and pick a length of 18 mm
6. Pick parallel construction line and pick line 1
7. Drag the cursor vertically and pick a point at 45
8. Pick Vertical and draw line 4 to meet the construction line
9. Pick Horizontal and draw a horizontal line of length 95 mm
10. Pick Vertical and draw a vertical line of length 15 (line 6)
11. Pick 2 Pts and draw line 7

The next step is to construct the holes. The hole at H1 is to be offset at 10 and 8 with diameter 6 mm. Holes H2 and H3 constructed on arcs 32 and 70 mm from H1.

1. Pick Cen & Pt/R ([Figure 33. Slotted Plate - 2 on page 102](#))
2. Pick OFFSET
3. Pick line 1 and then line 2
4. Define the center point at 8 (x-axis) and 10 (y-axis)
5. Drag the cursor and pick a radius of 3
6. Draw construction circles at 32 and 70 with H1 as the center (center and radius in CONSTRUCT)
7. Pick Cen & Pt/R and construct holes H2 and H3 having radius 5 (precise position is not important)
8. Delete the circular construction geometry.

Figure 32. Slotted Plate - 1

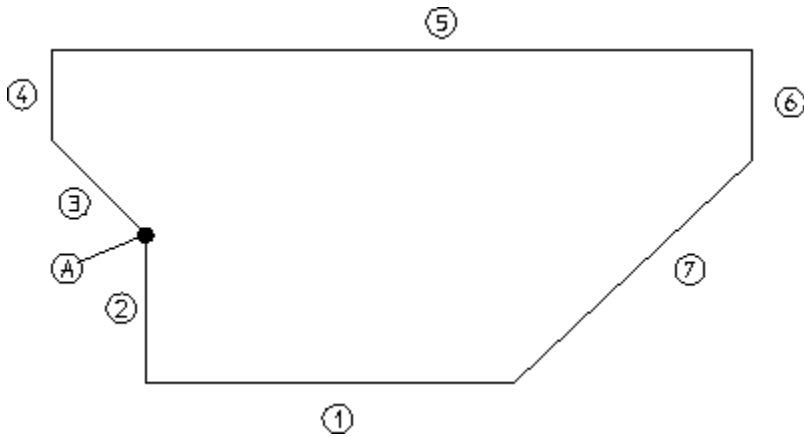
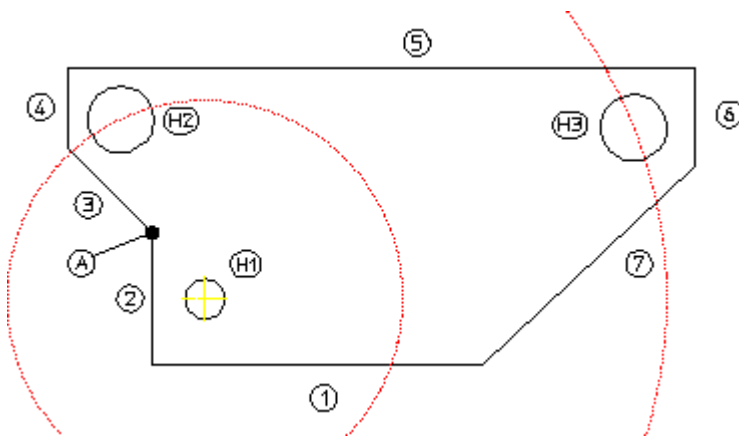

Figure 33. Slotted Plate - 2



The slot can be drawn freehand using the Polygon command. The only criteria is that the inside edge is parallel to line 7.

1. Pick parallel construction lines in CONSTRUCT and draw the parallel lines at a distance of 7 from lines 1, 5, and 7.
2. Pick Polygon and draw the slot starting at point B moving anticlockwise.

Finally, to cleanup the drawing, delete the construction geometry and add some fillets to the corners (FILLET in **CREATE 2**, size 5 mm).

Figure 34. Slotted Plate - 3

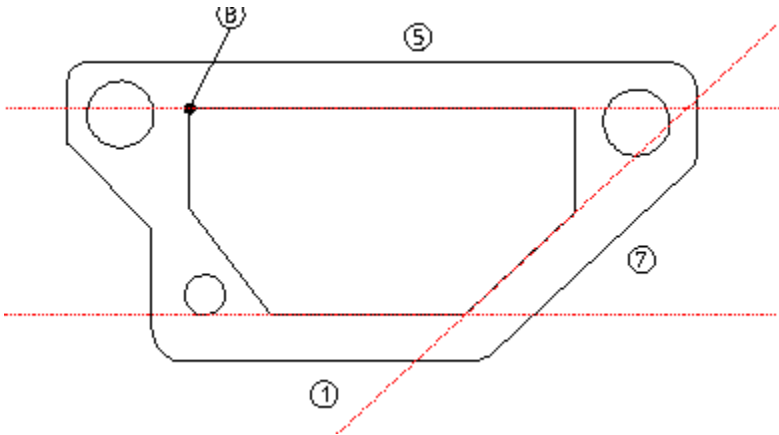

6

Drawing Methods

Drawing Construction Geometry	105
Drawing Construction Lines	105
Drawing Construction Circles	108
Drawing a Lever Using Construction Geometry	110
Using the Line Drawing Set	119
Creating Points	120
Using Overdraw	120
Drawing Lines	121
Drawing Circles	124
Drawing Arcs	126
Creating a Centerline	129
Creating Symmetric Elements	130
Indicating the Projected Reference Point	131
Creating a Reference Line	132
Splitting Elements	133
Merging Elements	134
Drawing Fillets	135
Drawing Chamfers	135
Keeping Corners	136
Creating a Polyline	137
Drawing Ellipses	138
Drawing Splines	142
Drawing Parallel Contours	158

This chapter shows how to produce a drawing using construction lines and the line drawing set. But before you start creating the geometry described here, switch off the Copilot functionality (via the SETUP menu).

Drawing Construction Geometry

Construction geometry is used for positioning and as an aid to drawing.

This section shows how to draw using construction lines and circles, just as you would normally do when working on a drawing board.

Construction lines differ from real lines in that they are considered to be of infinite length. Only full construction circles can be drawn.

When creating construction lines you can indicate a point for the line or enter the exact coordinates via the keyboard.

Enter coordinates using the following format:

2.5,3

12,4.8

5.35,6.1

The x and y coordinates are separated by a comma. When you have typed in the coordinates, press [Enter].

Drawing Construction Lines

Ten commands allow you to draw construction lines.

Construction Line by Two Points



Press this option, then indicate two points for the construction line required or enter the coordinates of two points.

Horizontal Construction Line



Enter the y coordinate of the line required, or use the cursor to identify a point through which the line must pass. To create several horizontal construction lines, simply enter the appropriate y coordinates separated by spaces.

Vertical Construction Line



Enter the x coordinate of the line required, or use the cursor to identify an existing point through which the line must pass. To create several vertical construction lines, simply enter the appropriate x coordinates separated by spaces.

Perpendicular Construction Line



You can create a construction line perpendicular to any existing line. Press the option, identify the existing line, and then indicate a point through which the perpendicular construction line must pass.

Parallel Construction Line



You can create construction lines parallel to any existing line in the following ways:

- Identify any existing line. Enter, or indicate a point for the parallel construction line to pass through. Multiple parallel construction lines are drawn by entering or indicating further points for the lines to pass through.
- Enter the required separation of the line. Now identify any existing line. Finally, indicate on which side the parallel construction line should be drawn. Multiple lines can be drawn at the previously set separation by indicating the original lines and the desired sides.
- A set of parallel lines can be drawn from an original line. For example, if you enter line separations in the form: 10 20 30 40, four parallel lines will be drawn at the given distances from the indicated line.

Construction Line Bisecting an Angle



You have the option of entering a value for the ratio of the division, otherwise the angle will be bisected. Indicate the apex, and then two points (usually on existing lines) to define the angle.

Construction Line at an Angle



When you select this option, Creo Elements/Direct Drafting will prompt you to indicate or enter the coordinates of a point through which the construction line must pass. Next enter the angle of the line with respect to the x axis. Note that a positive input will result in a line drawn counterclockwise from the x axis. The angle units will be those defined in the SETUP menu.

Bisecting Construction Lines

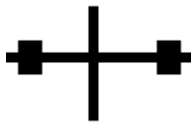

If you do not want the line concerned divided into two equal parts, enter a value for the ratio of the division. Then identify the two end points of the line. A construction line will be drawn perpendicular to the line at the appropriate position.

Construction Line Tangent from Point to Circle



This option enables you to create a construction line tangent to a circle or a spline and passing through a given point or at a set angle. Indicate the approximate point of tangency on the circle or spline and then indicate or enter a

point through which the construction line must pass. Or, indicate the approximate point of tangency, then enter the desired angle of the construction line. Note that the angle is measured in a counterclockwise arc from the horizontal.

Construction Line Tangent to Two Circles



You can create a construction line from a tangent to two circles or splines. Select the option and indicate the approximate point of tangency on each of the two circles or splines. The construction line created will be the one with points of tangency closest to those you indicated.

Drawing Construction Circles

Eight commands allow you to draw construction circles.

Circle by Three Points

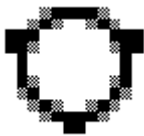

You can create a construction circle by indicating three points on the circumference. Pick the option and identify two circumference points. The construction circle created will vary with the movement of your cursor until you indicate the third point.

Construction Circle by Center and Circumference Point

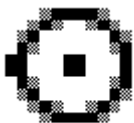

Indicate the center of the construction circle and either indicate a point on the circumference, or enter the radius required. If multiple concentric circles are required, enter or indicate the peripheral points or enter the desired radii.

Concentric Construction Circles

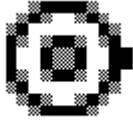

To create concentric construction circles, pick this option and identify the existing circle. Enter the radial offset of the new construction circle from the existing one, that is the difference between the two radii. To create several concentric construction circles, simply type in the appropriate radial offsets separated by spaces. Alternatively you can use the cursor to identify existing points through which the construction circles must pass.

Construction Circle by Diameter

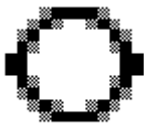

Indicate the two points as the two ends of the diameter for the required circle.

Construction Circle by Radius, Point (or Two Points) and Element

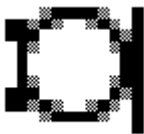

Indicate the approximate point of tangency of the construction circle on the existing element (which must not be a spline). Next indicate a point on the circumference, then either indicate another point or enter the required radius.

Construction Circle by Center and Element



Indicate the approximate point of tangency on the existing element. Next indicate the center of the construction circle to be drawn.

Construction Circle by Radius or Point and Two Elements



This option draws a construction circle of given radius tangential to two existing elements. Identify the approximate points of tangency (either lines or circles but no splines). Next enter or indicate a peripheral point on the construction circle or enter the desired radius. Creo Elements/Direct Drafting calculates the best solution, or informs you that no solution is possible.

Construction Circle by Three Elements



Indicate the approximate point of tangency of the construction circle on each of the three existing elements (none of which must be a spline).

Note

If the third tangency point you pick for a construction circle is located such that no circle is tangent to all three points, the first two points will move along the projection (notional extension) of the associated elements.

Drawing a Lever Using Construction Geometry

Use the following tutorial example to familiarize yourself with the various techniques used when producing a drawing with the aid of construction geometry.

[Table 2. Construct Block — Text Abbreviations on page 111](#) gives the abbreviations used throughout this tutorial for the **CONSTRUCT** block functions.

Table 2. Construct Block — Text Abbreviations





Construct Symbol	Text Abbreviation
	C_LINE HORIZONTAL
	C_LINE VERTICAL
	C_LINE PARALLEL
	C_CIRCLE CENTER
	C_CIRCLE TAN2_PT
	C_CIRCLE TAN_PT_PT
	C_LINE TAN2

Figure 35. Lever on page 112 shows the finished drawing of the lever.

Figure 35. Lever

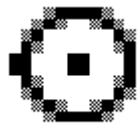
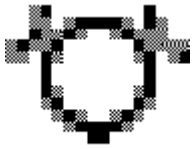
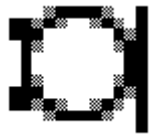

First draw horizontal and vertical construction lines. See [Figure 36. Horizontal and Vertical Construction Lines](#) on page 112.

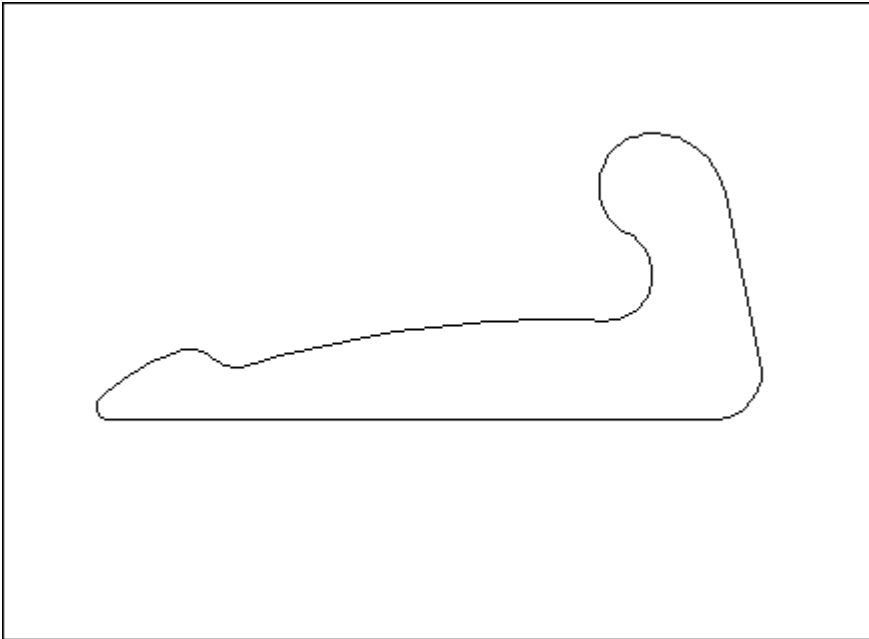
Figure 36. Horizontal and Vertical Construction Lines

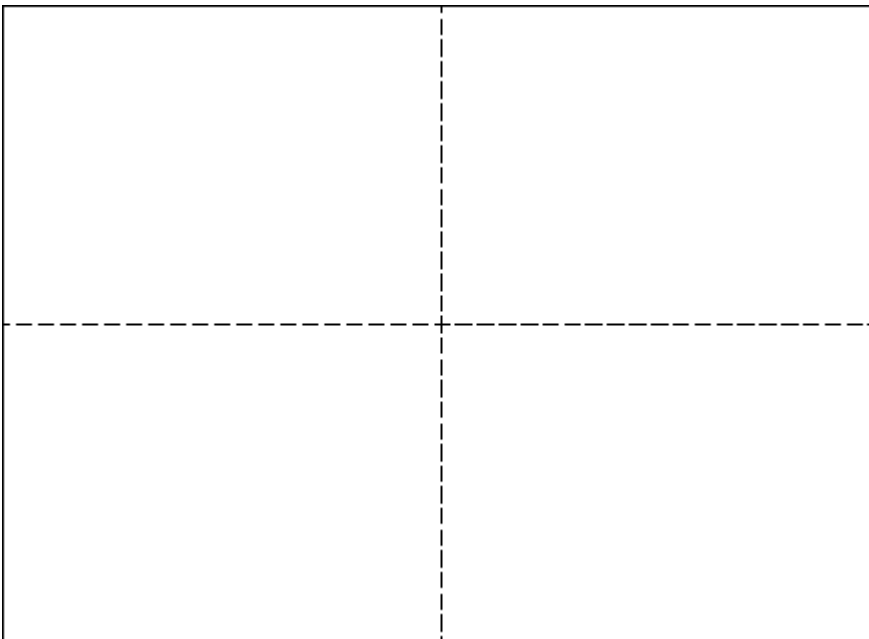

1. Press **CREATE**.
2. Press **CATCH**.

3. Press **SHOW, ALL** and **ON**.
4. Press **SHOW, VERTEX** and **OFF**.
5. Press **C_LINE HORIZONTAL** in the **CONSTRUCT** block.
6. Enter 0, 0.
7. Press **C_LINE VERTICAL** in the **CONSTRUCT** block..
8. Enter 0, 0.
9. Press **FIT** in the **WINDOW** block.
10. Press **END**.

Now draw some parallel horizontal construction lines. See [Figure 37. Parallel Construction Lines on page 113](#).

Figure 37. Parallel Construction Lines

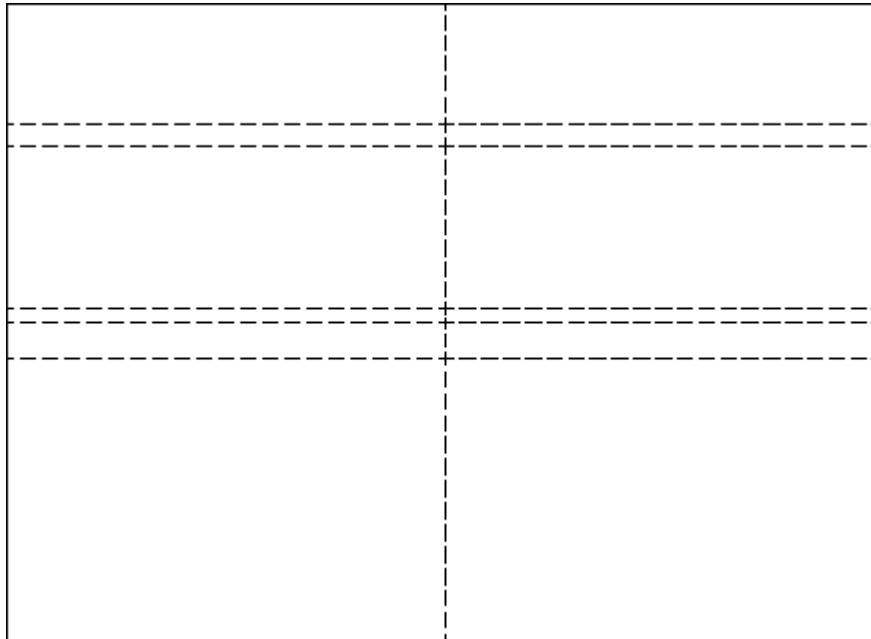

1. Press **C_LINE PARALLEL** in the **CONSTRUCT** block.
2. Enter -8 3 40 45.
3. Identify the horizontal line and then indicate a point above it.
4. Press **FIT** in the **WINDOW** block.

Draw some parallel vertical construction lines. See [Figure 38. Parallel Vertical Lines on page 114](#).

Figure 38. Parallel Vertical Lines

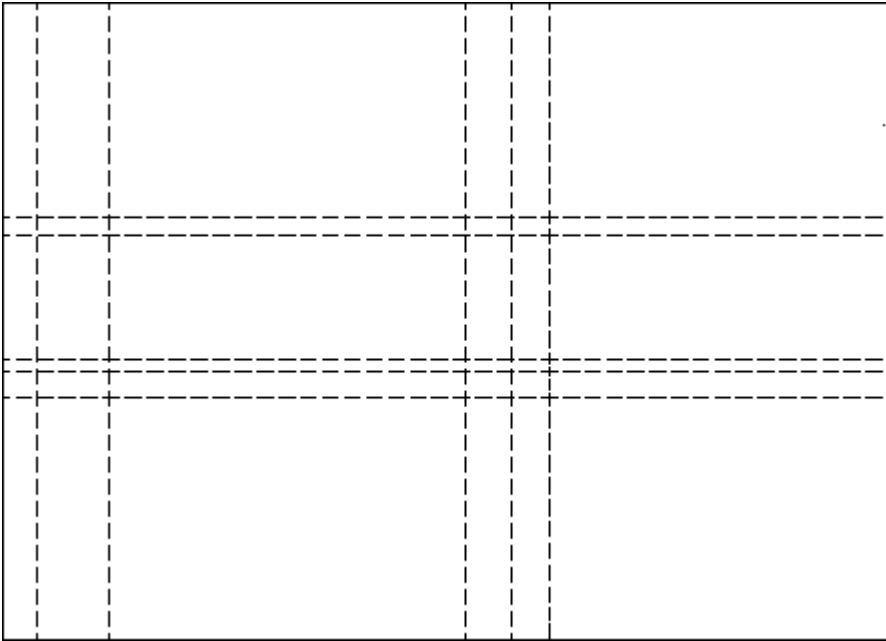

1. Enter 11 25 130 151 (**C_LINE PARALLEL** is still active).
2. Identify the vertical line and indicate a point to the left of it.
3. Press **FIT** in the **WINDOW** block.

Create three viewports in the drawing area. See [Figure 39. Three Viewports on page 115](#).

Figure 39. Three Viewports

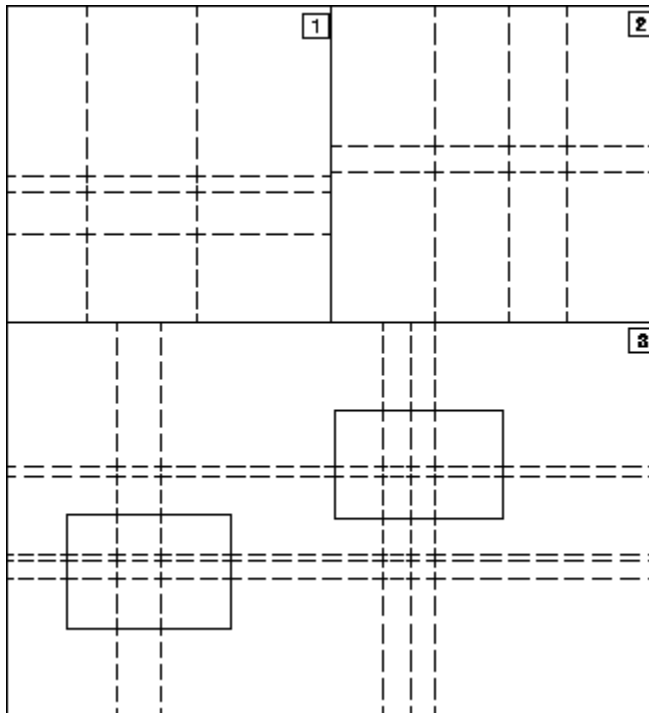

1. Press **DELETE** in **VIEWPORT**.
2. Press **ALL** in **SELECTION**.
3. Press **CREATE** in the **VIEWPORT** block.
4. Create viewport 1 as shown above by indicating 2 corner points of the viewport.
5. Repeat step 2 and create viewports 2 and 3.
Viewports 1 and 2 give you a closer look at certain areas of your drawing where you will do more complex work. Viewport 3 displays the entire drawing.
6. Press **CURRENT** in **VIEWPORT** and identify viewport 1.
7. Press **NEW** in **WINDOW** and indicate 2 points in viewport 3 as defined by the left hand rectangle.
8. Press **CURRENT** in **VIEWPORT** and identify viewport 2.
9. Press **NEW** in **WINDOW** and indicate 2 points in viewport 3 as defined by the right hand rectangle.

Now create some construction circles. See [Figure 40. Construction Circles on page 116](#).

Figure 40. Construction Circles

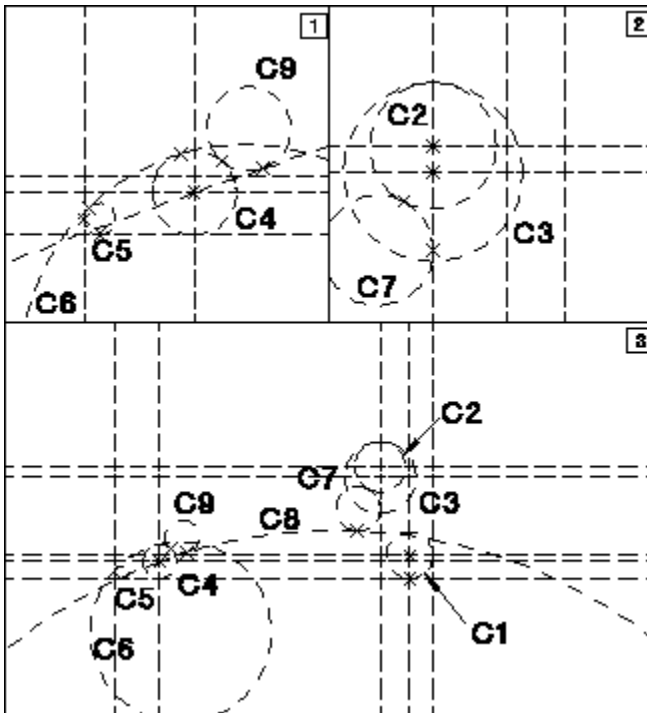

1. Press **ALL** in the **CATCH** block.
2. C1 — Press **C_CIRCLE CENTER** in **CONSTRUCT** and identify the center point and lower circumference point (in viewport 3).
3. C2 — Press **C_CIRCLE CENTER** in **CONSTRUCT** and identify the center point and enter 12 (in viewport 2).
4. C3 — Press **C_CIRCLE CENTER** in **CONSTRUCT** and identify the center point and enter 17 (in viewport 2).
5. C4 — Press **C_CIRCLE CENTER** in **CONSTRUCT** and identify the center point and enter 8 (in viewport 1).
6. Press **C_CIRCLE TAN2_PT** in **CONSTRUCT**.
7. C5 — Indicate the two tangent points and enter the radius 3 (in viewport 1).
8. C6 — Indicate the two tangent points and enter the radius 43 (in viewport 1).
9. C7 — Indicate the two tangent points and enter the radius 10.5 (in viewport 2).
10. Press **C_CIRCLE TAN_PT_PT** in the **CONSTRUCT** block.
11. C8 — Indicate the tangent point to C7 and the center point of C4. Enter the radius 246 (in viewport 3).
12. Press **C_CIRCLE TAN2_PT** in the **CONSTRUCT** block.

13. C9 — Indicate the two tangent points and enter the radius 8 (in viewport 3).
Draw a construction line tangent to C1 and C3. See [Figure 41. Construction Line Tangent](#) on page 117.

Figure 41. Construction Line Tangent

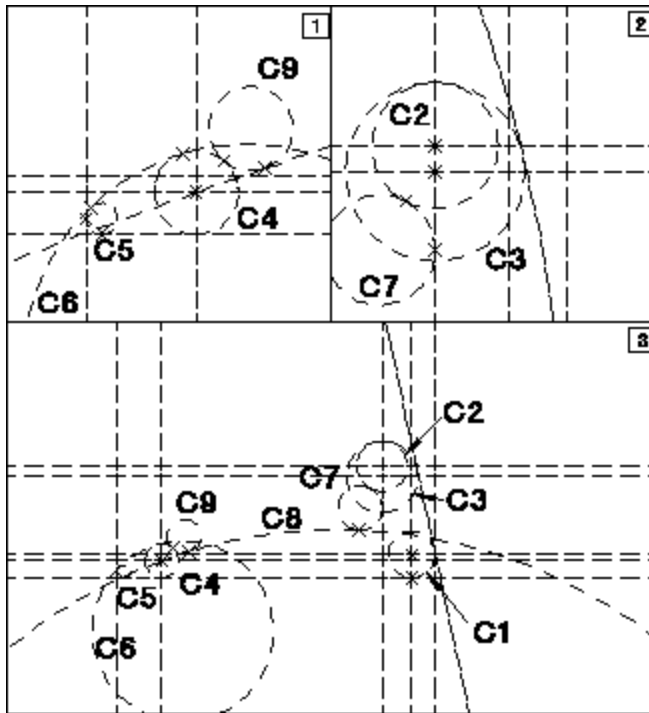

1. Press C_LINE TAN2 in the **CONSTRUCT** block.
2. Indicate the tangent points on C1 and C3 (in viewport 3).

Now pick OVERDRAW in **CREATE** to draw the lever itself. See [Figure 42. Drawing the Lever](#) on page 118.

Figure 42. Drawing the Lever

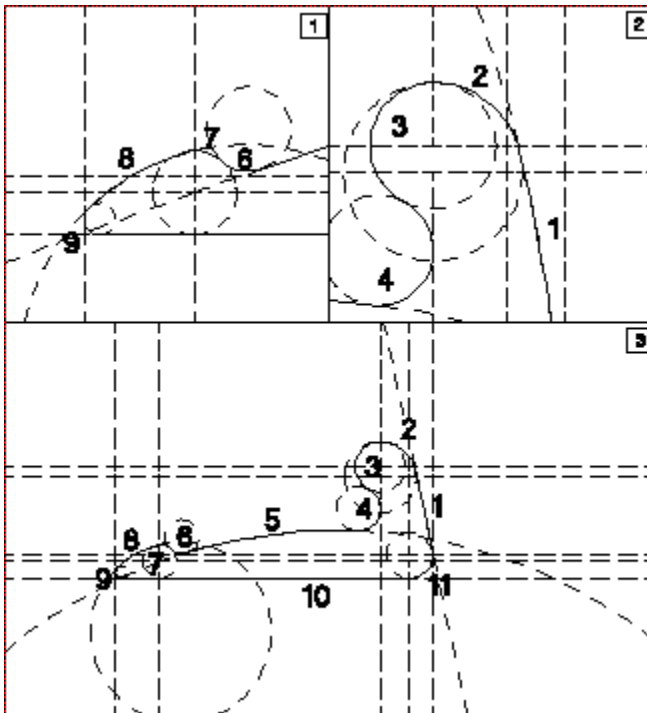

1. Press **CREATE**.
2. Pick **OVERDRAW**.
3. Indicate point 11/1 as the start point.
4. Indicate a point on element 1 and indicate point 1/2.
5. Indicate a point on element 2 and indicate point 2/3.
6. Indicate a point on element 3 and indicate point 3/4.
7. Indicate a point on element 4 and indicate point 4/5.
8. Indicate a point on element 5 and indicate point 5/6.

 **Note**

When drawing the arc on C9, ensure that the cursor is nearer to C9 than to any other line. If you make a mistake, pick **OVERDRAW** and window in on the area by pressing **NEW** in the **WINDOW** block.

9. Continue with this procedure for elements 6, 7, 8, 9, 10, and 11.

Using the Line Drawing Set

To enter drawing mode, press the **CREATE** block. The menu appears on the screen; it contains the following commands:

- POINT
- OVERDRAW
- LINE
- CIRCLE
- ARC
- SPLITTING
- SPLIT
- MERGE
- OFFSET
- CENTERLINE
- SYM LINE
- REF LINE

The second menu contains the commands:

- EQUIDIST
- FILLET
- CHANGE FIL
- CHAMFER
- CORNER
- CONVERT
- SUBDIV SPL
- POLYELEM
- ELLIPSE
- HYPERBOLA
- PARABOLA

Switch between the two menus by picking MENU 1 or MENU 2 from the bottom of the screen menu.

Picking SPLINE gives access to the SPLINE menu (see [Drawing Splines on page 142](#)). The SPLINE menu contains the commands:

- INTPOL SPL
- CONTRL SPL

-
- CHG PNT
 - CHG I PNT
 - CHG C PNT
 - DEL I PNT
 - ADD I PNT
 - DEL C PNT
 - ADD C PNT
 - DEL TANG
 - ADD TANG
 - CNTRL POLY
 - TRIMMING

Creating Points

Points can be created anywhere on your drawing simply by picking the POINT command and indicating the position with the cursor, or entering the required coordinates.

If you have difficulty deleting points, try enclosing them in a box for deletion.

Using Overdraw

Use OVERDRAW to draw a contour between intersection points in the construction geometry. The lines will be drawn over the existing construction lines and circles just as you would line in a contour by hand.

Additionally, it is now not necessary to pick each construction geometry intersection point before identifying the line or arc you want to draw over. You simply pick the next construction geometry element and Creo Elements/Direct Drafting calculates the intersection point. This saves one pick for every overdraw action.

To use the OVERDRAW command:

1. Draw the construction geometry as shown in [Figure 43. Using the OVERDRAW Command on page 121](#).
2. Click OVERDRAW
3. Identify the start point (1)
4. Identify points 2 to 14 (end point)

Figure 43. Using the OVERDRAW Command

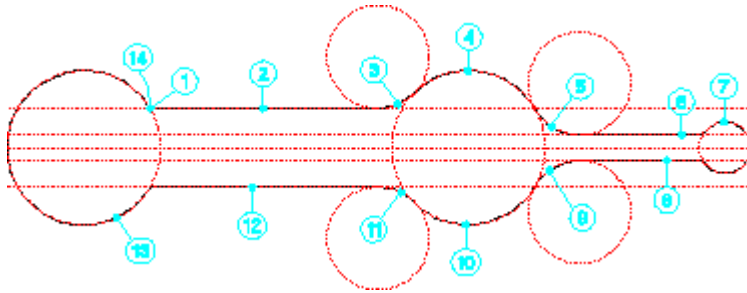

The OVERDRAW command also supports multiple UNDO operations.

Drawing Lines

Ten commands allow you to draw lines:

- 2 Pts
- Polygon
- Horizontal
- Vertical
- Parallel
- Perpend
- TanArc &Pt
- Tan 2 Arcs
- Ang & Len
- Rectangle

Line by Two Points

This is the default option.

1. Press **CREATE**.
2. Pick 2 Pts or the LINE command.
3. Indicate the start and end point of the line required.

Polygon

To draw a polygon:

1. Press **CREATE**.
2. Pick Polygon.

-
3. Indicate the start point, and then a sequence of end points.

Note that the result does not have to be a closed polygon. The lines are treated as individual elements and must therefore be deleted individually or enclosed in a box for deletion.

Once you have closed a polygon, you can continue by indicating the first point of a new polygon.

Horizontal Line

This option is similar to line by two points but only draws a horizontal line.

To draw a horizontal line:

1. Press **CREATE**.
2. Pick Horizontal.
3. Indicate the start point of the line.
4. Indicate the end point of the line, or enter the length of the line.

If you indicate an end point, the line is drawn through that point.

Vertical Line

This option is similar to line by two points but only draws a vertical line.

To draw a vertical line:

1. Press **CREATE**.
2. Pick Vertical.
3. Indicate the start point of the line.
4. Indicate the end point of the line, or enter the length of the line.

If you indicate an end point, the line is drawn through that point.

Parallel Line

To draw a line parallel to an existing line:

1. Press **CREATE**.
2. Pick **Parallel**.
3. Identify the existing line.
4. Indicate a point on the new line.

You can use the ruler to ensure that the line is drawn at a given distance (refer to [Using the Ruler/Grid on page 73](#)).

Alternatively:

1. Pick **Parallel**.
2. Enter the distance required.
3. Identify the existing line.
4. Indicate the side on which the parallel line should be drawn.

Perpendicular Line

To draw a perpendicular line:

1. Press **CREATE**.
2. Pick **Perpend**.
3. Identify the existing line.
4. Indicate the point from which the perpendicular should be dropped.

Alternatively:

1. Pick **Perpend**.
2. Identify the existing line.
3. Indicate a point on the existing line.
4. Enter the length of the perpendicular. If the perpendicular drawn is on the wrong side of the line, repeat the operation using the opposite sign for the entered value.

Tangent from Point to Arc or Circle

This option enables you to draw a tangent to a circular element from any given point.

1. Press **CREATE**.
2. Pick **TanArc &Pt**.
3. Indicate the approximate point of tangency on the arc or circle.
4. Indicate the point from which the tangent should be drawn.

The system will inform you if such a tangent is not possible.

Line Tangent to Two Arcs or Circles

To draw a tangent from one circular element to another:

1. Press **CREATE**.
2. Pick **Tan 2 Arcs**.

-
3. Indicate the approximate point of tangency on each of the two arcs or circles.

The tangent drawn will be the one with points of tangency closest to those indicated.

Line with Given Length and Angle

To draw a line with a given length and angle:

1. Press **CREATE**.
2. Pick **Ang & Len**.
3. Indicate the start point of the line.
4. Enter the angle of the line with respect to the x-axis.
5. Enter the length of the line.

The line will be drawn accordingly.

Rectangle

Rectangles can be created as whole entities, but the system treats them as four individual line elements. This means the sides of a rectangle can be deleted or manipulated individually.

To draw a rectangle:

1. Press **CREATE**.
2. Pick **Rectangle**.
3. Indicate two diagonal corner points.

You will see that the rectangle moves with your cursor until the second point is defined.

Drawing Circles

The five commands used for drawing circles are:

- Cen & Pt/R
- 3 Pts
- Tan2 &Pt/R
- Concentric
- Diameter

Circle by Center and Circumference Point

This is the default option. Therefore you can either pick Cen & Pt/R or the CIRCLE command itself.

To draw a circle by indicating the center and point:

1. Press **CREATE**.
2. Pick **Cen & Pt/R**.
3. Indicate the center of the circle.
4. Indicate a point on the circumference, or enter the length of the radius. The circle moves with the cursor until the circumference point is defined.

You can create additional concentric circles by indicating additional points or radii.

Circle by Three Points

To draw the circle by indicating three points on the circumference:

1. Press **CREATE**.
2. Pick **3 Pts**.
3. Indicate three circumference points.

The circle drawn will vary with the movement of the cursor until the third point is defined.

Circle by Radius and Two Elements

To draw a circle of given radius tangential to two existing elements:

1. Press **CREATE**.
2. Pick **Tan2 &Pt/R**.
3. Indicate the approximate tangent points on the two elements.
4. Enter the radius required.

The elements can be either lines, arcs or circles. Creo Elements/Direct Drafting will calculate the best solution or, if no solution is possible, it will suggest a valid radius.

Concentric Circles

To draw concentric circles:

1. Press **CREATE**.
2. Pick Concentric.

-
3. Identify the existing circle.
 4. Indicate the desired circumference point and the circle will be drawn.

To draw further concentric circles, simply indicate circumference points.

Alternatively:

1. Pick Concentric.
2. Identify the existing circle.
3. Enter the radial offset.

Circle by Diameter

To draw a circle by diameter:

1. Press **CREATE**.
2. Pick Diameter.
3. Indicate the two diameter end points for the circle required.

Drawing Arcs

This section shows how to use the seven commands for drawing arcs. Arcs are normally drawn in a counterclockwise direction. The options are:

- 3 Pts
- Cen R Angs
- Cen & Ends
- Concentric
- Pt R Angs
- Diameter
- Smooth

Figure 44. Arc Geometry on page 127 shows arc geometry.

Figure 44. Arc Geometry

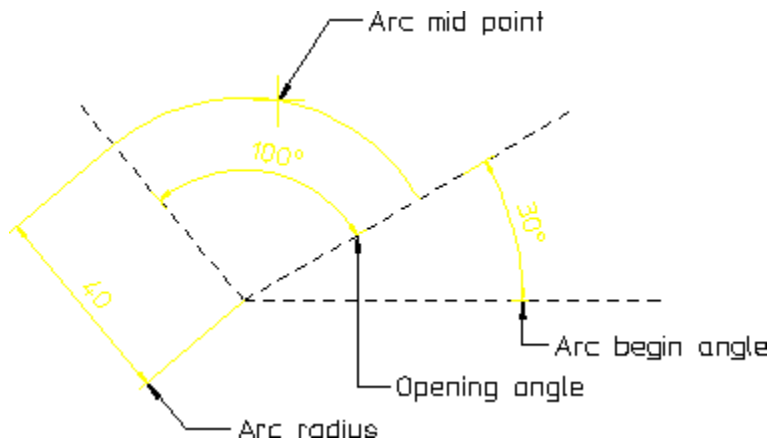

Arc by Three Points

To draw an arc through three points:

1. Press **CREATE**.
2. Pick **3 Pts** or **ARC**.
3. Indicate the two end points of the required arc.
4. Indicate a third point on the arc.

The arc drawn will vary with the movement of the cursor until the third point is defined.

Arc by Center and Radius

To draw an arc with a given center and radius:

1. Press **CREATE**.
2. Pick **Cen R Angs**.
3. Indicate the center point.
4. Enter the radius required.
5. Enter the start angle and the end angle of the arc. Alternatively, you can define the angles by indicating two points.

Arc by Center and End Points

1. Press **CREATE**.
2. Pick **Cen & Ends**.
3. Indicate the center of the arc.

-
4. Indicate the radius (arc start point).
 5. Indicate a third point. It does not need to lie on the arc plane, but its line defines the end of the arc.

Concentric Arcs

To draw concentric arcs:

1. Press **CREATE**.
2. Pick Concentric.
3. Identify the existing arc.
4. Indicate a point on the required arc.

Simply indicate points to draw further concentric arcs. You can also enter the radial offsets.

Arc by Mid-Point and Radius

To draw an arc by specifying the arc mid-point and radius:

1. Press **CREATE**.
2. Pick Pt R Angs.
3. Enter or indicate the mid-point of the desired arc.
4. Indicate the arc radius.
5. Enter the arc begin (or end) angle (angles are measured counterclockwise from the horizontal).
6. Enter the arc opening angle.

Arc by Diameter

1. Press **CREATE**.
2. Pick Diameter.
3. Indicate the diameter end points and an arc will be drawn between them.

The resulting position of the arc will depend upon which diameter point is indicated first.

Smooth Connecting Arc

To draw a smooth connecting arc:

1. Press **CREATE**.

2. Pick Smooth.
3. Identify an element end point (line, circle, and so on).
4. Indicate the end point of the arc.

The arc is drawn tangential to the element you have identified. With each further point indicated, another arc is drawn tangential to the previous one. In [Figure 45. Smooth Connecting Arcs on page 129](#), points 1 to 4 have been picked in succession.

Figure 45. Smooth Connecting Arcs

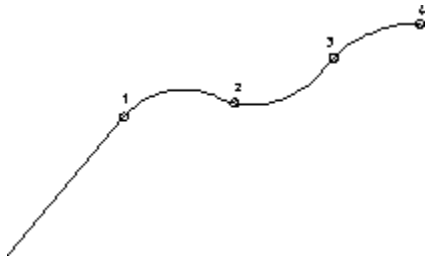

Creating a Centerline

This command lets you create a centerline for a circular element. This command is particularly useful because it speeds-up the early design phase. The centerline becomes part of the circular element and is moved or deleted if the associated circular element is moved or deleted.

To create a centerline, pick CENTERLINE in **CREATE 2** and identify the circle. [Figure 46. Creating a Centerline on page 129](#) shows the top circles before and after adding a centerline. The different appearance of the centerlines is done by changing absolute and relative values. Refer to the online help on how to do this (`help centerline`).

Figure 46. Creating a Centerline

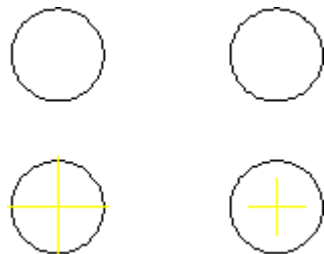

When you dimension centerlines and then make a modification, the dimension is automatically updated. When asked to identify the first element, pick the center point of the circle (use CATCH CENTER).

Figure 47. Effect of Changing the Position

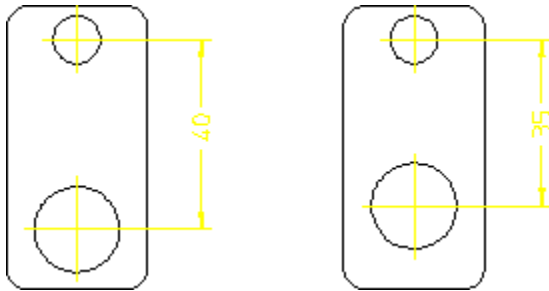

Use **CHG CENLIN** to change the position of the centerline.

Creating Symmetric Elements

The **SYM LINE** command lets you create elements that are:

- Symmetric with existing elements
- Associated (or anchored) to the defining elements.

When you modify the defining elements, the associated element is modified accordingly.

To draw an associated element:

1. Draw a polygon similar to that shown in [Figure 48. Associated Symmetric Elements on page 131](#).
2. Create circle 1 having diameter 1 mm.
3. Create circle 2 having diameter 3 mm.
4. Pick **SYM LINE** in **CREATE 1**.
5. Pick circle at point 1.
6. Pick circle at point 2.

Creo Elements/Direct Drafting draws the associated circle (point 3) that is:

- Midway between circles 1 and 2.
- Is 2 mm in diameter (half the sum of the defining diameters).

Figure 48. Associated Symmetric Elements

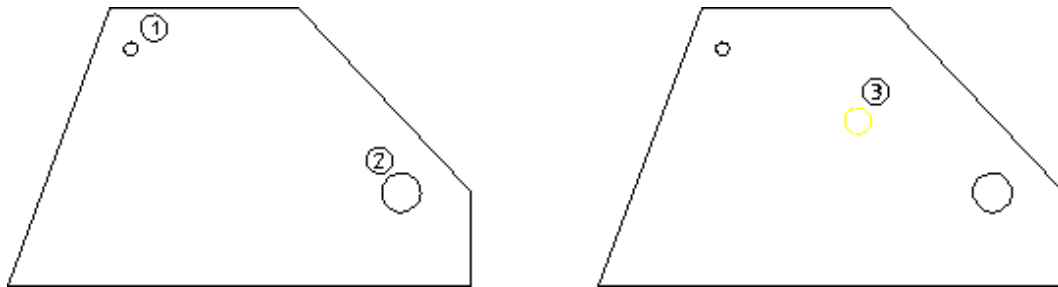

Use Chg SymLin to change the position of the centerline.

Now try moving the circle at position 2 and notice how the associated element also moves.

Figure 49. Effect of Moving the Defining Circle

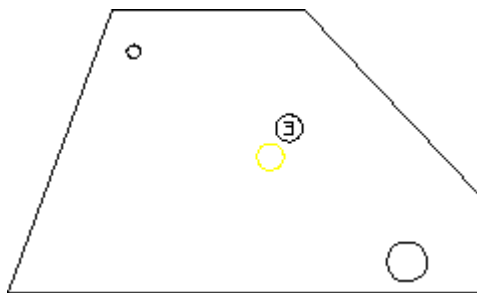
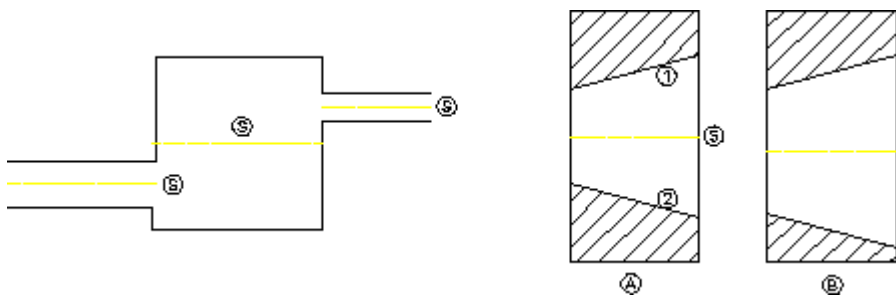

Figure 50. Finding Lines of Symmetry on page 131 shows another example of where to use the SYM LINE command.

Figure 50. Finding Lines of Symmetry



Indicating the Projected Reference Point

The "projected reference point" is the point at which the extended traces of two existing elements (line-line, line-arc, and arc-arc) would meet. To indicate this point in your drawing:

1. Press **ProjRefPnt** in **CREATE 2**.

2. Identify the first element.
3. Identify the second element.

The point where the traces of the two elements meet is now shown in your drawing. When one or both the elements are arcs, the intersection point that is closest to both the elements is the projected reference point.

Note that this reference point (plus the associated traces) are fully associative:

- These items can be included in dimensions.
- These items are preserved even when you perform **Modify** operations.

 **Note**

You cannot have projected reference points across parts.

Figure 51 on page 104 shows an example of a projected reference point.

Figure 51. Projected Reference Point

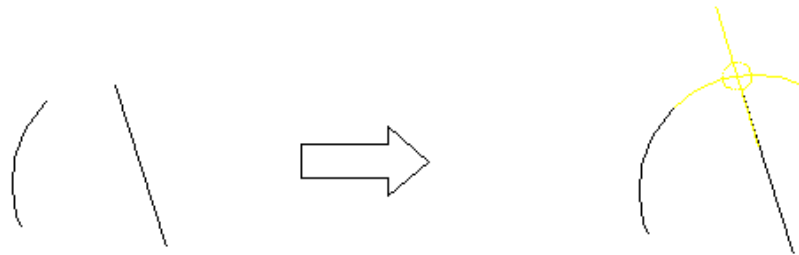

Creating a Reference Line

The REF LINE command lets you create a reference line to an element that may later be repositioned.

Creating reference lines helps to speed-up the modification phase as it saves you time repositioning individual elements.

To draw a reference line:

1. Create two elements and some text.
2. Pick REF LINE in the **CREATE 1** menu.
3. Identify the associated element (source element)
4. Identify the target element

Creo Elements/Direct Drafting draws a reference line between the two elements.

Figure 52. Effect of Moving the Target Element

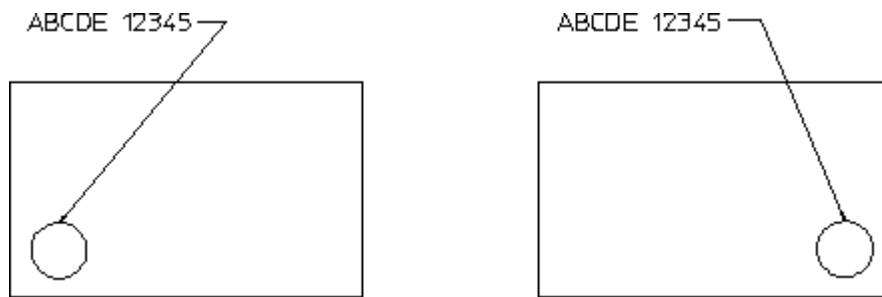

Splitting Elements

It is often useful to split an element (line, circle, and so on) into two or more parts.

By doing this, the segments of lines that intersect can be treated as separate elements and deleted individually.

Splitting Elements Automatically

Before you begin to draw, pick **Splitting On** in **CREATE** to automatically split elements at their intersection points. This technique keeps contours clean, which is important for automatic hatching.

When a new element is created, Creo Elements/Direct Drafting checks to see if one of the end points of the new element lies on other elements. If so, it splits the other element at that point if possible. When the new element crosses the old element, the old element will not be split.

[Figure 53. Splitting Elements on page 133](#) shows the principle of splitting elements.

Figure 53. Splitting Elements

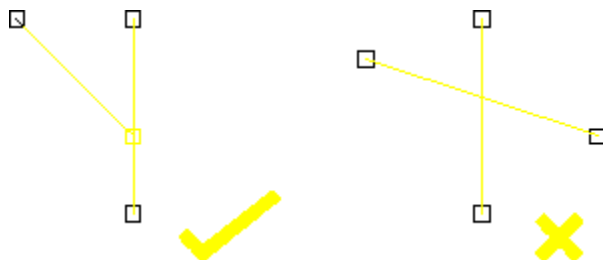

Note

If you are deleting an element whose end point lies on other elements and Splitting On is active, Creo Elements/Direct Drafting will attempt to merge the remaining elements automatically into one.

Splitting Single Element/Elements in a Box

To split a single element:

1. Press **CREATE**.
2. Pick Elem/Box in SPLIT.
3. Identify the element to be split.

Creo Elements/Direct Drafting highlights the chosen element.

4. Indicate the point where the element should be split.

Alternatively, to split several elements automatically at their intersection points:

1. Pick Element/Box.
2. Box the elements to be split (be sure to fully enclose the elements in the box).

To see that all elements have been split, press SHOW POINTS. All existing points will be highlighted.

Dividing an Element Fractionally

To split an element at a point along a fraction of its length:

1. Press **CREATE**.
2. Pick Split On.
3. Pick Divide Len in SPLIT.
4. Identify the ends of the element to be split.
5. Enter a mixing factor (for example, 0.2) or indicate the desired split point.

Merging Elements

To merge elements that have been split:

1. Press **CREATE**.
2. Pick **MERGE**.
3. Identify the elements to be merged.

The elements will then be returned to their original state. Intersection points will no longer be marked when you press **SHOW POINTS**.

Drawing Fillets

To draw a fillet radius:

1. Press **CREATE**.
2. Pick **FILLET**.
3. Enter the radius.
4. Identify the two elements between which the fillet should be drawn, or identify the vertex.

The fillet radius will be drawn and by default the corner point will be deleted. If you do not want the corner to be deleted, pick Keep in CORNER before identifying the elements or vertex.

Changing Fillets

To change fillet radii you have already created:

1. Press **CREATE**.
2. Pick **CHANGE FIL**.
3. Enter the new fillet radius.
4. Identify the individual fillets to be changed or enclose them in a box.

You also can change all existing fillets by pressing the option **ALL** in the **SELECTION** block. To remove all fillets, enter a radius of zero.

Drawing Chamfers

Four methods of drawing a chamfer are described in this section. By default the corner point will be deleted after the chamfer is drawn. If you do not want the corner to be deleted, pick Keep in CORNER before you choose a chamfer option.

Chamfer by Two Points

This is the default option. To draw a chamfer by two points:

1. Press **CREATE**.
2. Pick **2 Pts** or the **CHAMFER** command itself.
3. Indicate the start point and end point of the required chamfer.

Chamfer by Two Distances

To draw a chamfer by specifying two different distances:

1. Press **CREATE**.
2. Pick **Dist Dist**.
3. Enter the distance for chamfer along the first element.
4. Enter the distance for chamfer along the second element.
5. Identify the first element.
6. Identify the second element.

Chamfer at Angle to First Line

To draw a chamfer at a given angle to the first line and at a given distance from the vertex:

1. Press **CREATE**.
2. Pick **Dist Ang**.
3. Enter the angle between the chamfer and the first element.
4. Enter the chamfer distance.
5. Identify the first element.
6. Identify the second element.

Chamfer at Distance from Vertex

To draw a chamfer at a given distance from the vertex along each line:

1. Press **CREATE**.
2. Pick **Vertex**.
3. Enter the chamfer distance.
4. Identify the vertex (the point where the two lines intersect).

Keeping Corners

When drawing fillets or chamfers, you can keep or delete the corners:

1. Press **CREATE**.
2. Pick **Keep** or **No Keep** (default) in **CORNER**.

Creating a Polyline

Polylines can be created with the POLYELEM command.

Polylines are useful during the modification phase (for example, moving furniture around room).

The following example shows some of the differences of working with polyline elements and non-polyline elements. Drawing A is a standard polygon created with Polygon in **CREATE**. To modify the pensizes of drawing A to produce drawing A1, you need to pick points 1, 2, and 3 (for the purpose of this example, it is assumed that only individual elements can be picked).

Drawing B is similar to drawing A but has been converted into a polyline. Because drawing B is a polyline, it acts like a single element and you need only pick point 4 to modify the complete shape (drawing B1).

Figure 54. Modifying Polyline and Non-Polyline Elements

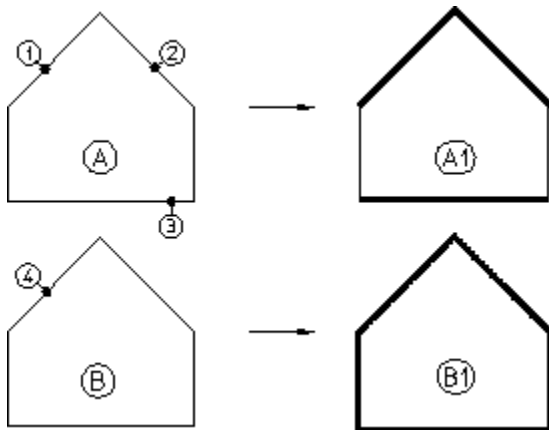

The following procedure describes how to create a polyline from a polygon and then modify the polyline by changing its pensize and shape.

To create a polyline:

1. Create a polygon
2. Pick **Create** in **POLYELEM**
3. Identify a vertex point
4. Identify an element (one that ends at the vertex)
5. Pick adjacent elements (or pick the last element)
6. Pick **END** when the desired shape is defined.

The polygon is now a polyline. To test it, change the pensize:

1. Pick **Chg PS**
2. Enter a value (for example, 0.5)

-
3. Select one element of the polyline.

Notice how the complete shape changes—not just the selected element.

Similarly, you can modify the shape of the polyline:

1. Pick **No Keep** in **STRETCH**
2. Pick a vertex point (or enclose it in a box)
3. Indicate the new position of the point

Smashing a Polyline

Use the Smash option to smash the polyline into individual elements.

Drawing Ellipses

The three commands used for drawing an ellipse are:

- 2 Verts & Pt
- Cen Ang R
- Cen & Pts
- 2 Foc&Pt
- FcAngExMaj

Ellipse by Vertices and Point

This is the default option. To draw an ellipse by vertices and point:

1. Press **CREATE**.
2. Pick **2 Verts&Pt**.
3. Indicate the two vertices of the major axis of the required ellipse.
4. Indicate one point on the circumference.

Ellipse by Center, Angle and Radii

To draw an ellipse by center, angle and radii:

1. Press **CREATE**.

See [Figure 55. Ellipse by Center, Angle and Radii on page 139](#).

Figure 55. Ellipse by Center, Angle and Radii

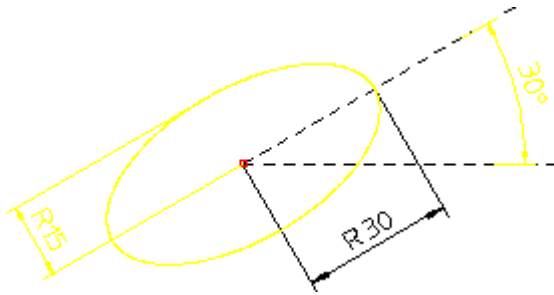

1. Pick Cen Ang R.
2. Indicate the center of the required ellipse.
3. Enter the angle the major axis makes with the x axis (30° in [Figure 55. Ellipse by Center, Angle and Radii on page 139](#)).
4. Enter the major radius (30mm in [Figure 55. Ellipse by Center, Angle and Radii on page 139](#)).
5. Enter the minor radius (15mm in [Figure 55. Ellipse by Center, Angle and Radii on page 139](#)).

Ellipse by Center and Two Points

To draw an ellipse using the center and two points:

1. Press **CREATE**.
2. Pick **Cen & Pts**.
3. Indicate the center point of the ellipse.
4. Indicate the first point on the circumference.
5. Indicate the second point on the circumference.

Ellipse by Focus and Points

Use the **ELLIPSE** command options 2 Foc&Pt and FcAngExMaj to create elliptical shapes by defining the focus point and major radius.

Figure 56. Ellipses by Focus, Point, Angle

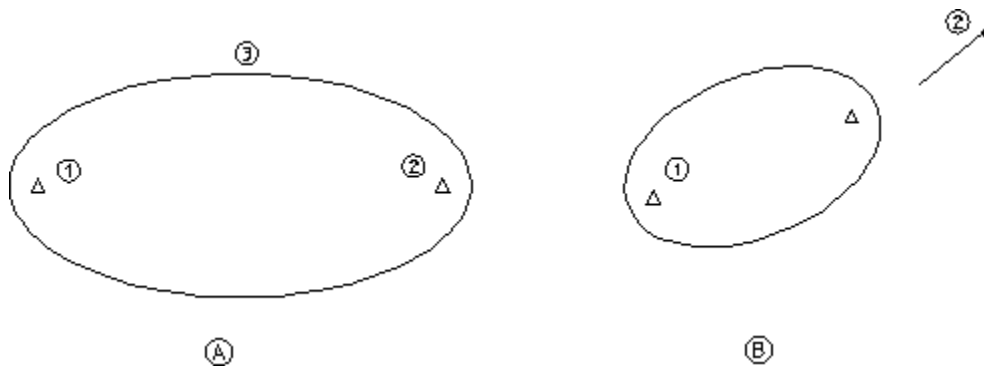

To create an ellipse by specifying the focus point (drawing A):

1. Pick 2 Foc&Pt
2. Pick first focal point (1)
3. Pick second focal point (2)
4. Pick a point on the circumference (3)

To create an ellipse by specifying the focus and direction (drawing B):

1. Pick **FcAngExMaj**
2. Pick first focal point (point 1)
3. Pick the direction of the major axis (point 2)
4. Enter an **Ex-value** (for example, 0.8)
5. Enter a value for the major radius (for example, 15)

Creating Hyperbolas and Parabolas

Use the commands **HYPERBOLA** and **PARABOLA** in **CREATE** to draw hyperbolas and parabolas.

Being able to draw parabolas is particularly useful in the design of headlights.

To draw a hyperbola:

1. Pick **CenFocEnd** in **HYPERBOLA**.
2. Pick the center of the hyperbola (point 1)
3. Pick the focus of the hyperbola (point 2)
4. Pick the end of the hyperbola (point 3)

Figure 57. Hyperbola by Center, Focus, and End

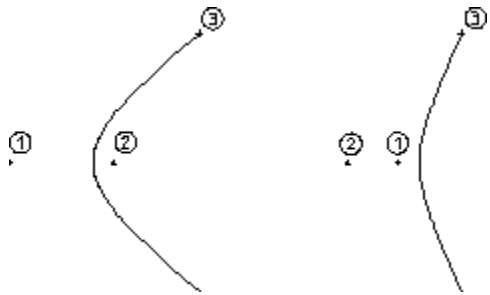

To draw a hyperbola tangential to existing geometry:

1. Pick **CenTngFoc** in **HYPERBOLA**.
2. Pick the center of the hyperbola (point 1)
3. Pick a tangential point (point 2)
4. Pick the focus of the hyperbola (point 3)

Figure 58. Hyperbola by Center, Tangent, and Focus

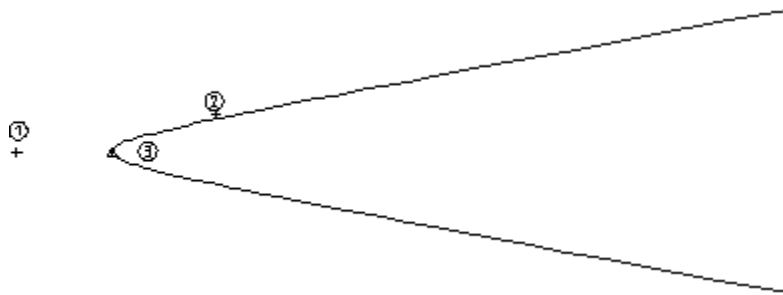

Creo Elements/Direct Drafting automatically adds the tangential construction geometry.

To draw a parabola:

1. Pick **CenFoc** in **PARABOLA**.
2. Pick the center of the parabola (point 1)
3. Pick the focus of the parabola (point 2)

Figure 59. Parabola by Center and Focus

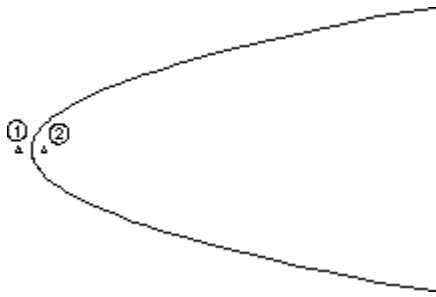

To draw a parabola in a specific direction:

1. Pick **FocDirEnd** in **PARABOLA**.
2. Pick the focus of the parabola (point 1)
3. Pick the direction of the parabola (point 2)
4. Pick the end of the parabola (point 3)

Figure 60. Parabola by Direction

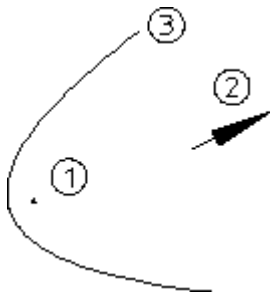

Drawing Splines

This section describes how to draw spline curves. Spline curves are special types of smooth curves that pass through given data points. When you have specified the data points, Creo Elements/Direct Drafting uses a powerful technique (B-spline mathematics) to produce the shape. The following diagram shows some possible uses of spline curves.

Figure 61. Typical Spline Curves: Engine Manifold, Pipe Tree, Racquet Head

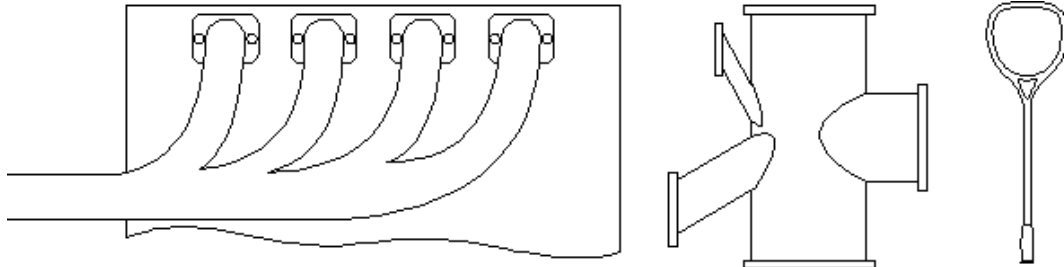

Spline Components

Figure 62. Spline Components on page 143 shows a simple spline with its control polygon visible. The control polygon can be thought of as a convex hull containing the spline. Points on the spline curve are called interpolation points, points on the control polygon are called control points.

Figure 62. Spline Components

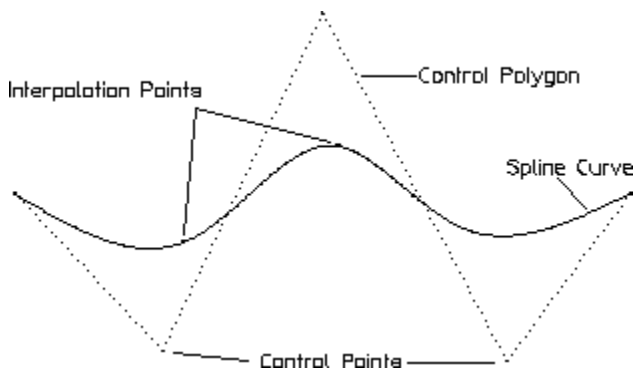

Creo Elements/Direct Drafting provides two basic spline shapes:

- Open
- Closed

Figure 63. Two Basic Spline Options

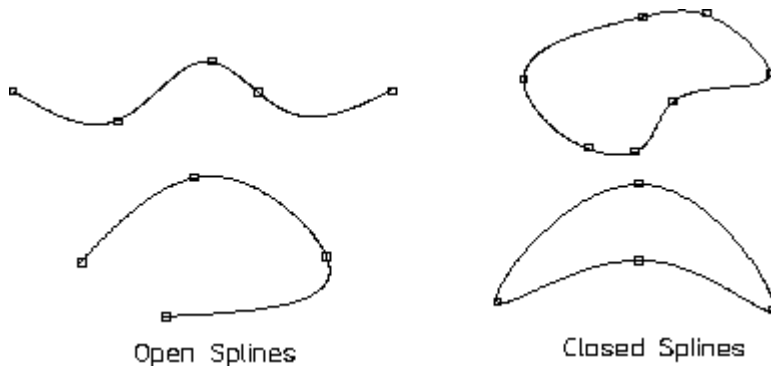

Using the SPLINE Command

The following is a quick overview of using the SPLINE command and its options. You can find the SPLINE command in the **CREATE** menu.

Drawing a Spline by Specifying Interpolation Points

1. Pick **INTPOL SPL**.
2. Pick a sequence of interpolation points.
3. Press **END**.

Creo Elements/Direct Drafting draws a spline curve through the points you specified. You can also draw a spline by specifying the control points, as described in the following.

Drawing a Spline by Specifying Control Points

1. Pick **CONTRL SPL**.
2. Pick a sequence of control points.
3. Press **END**.

Creo Elements/Direct Drafting draws a spline curve based on the control points you specified.

Drawing an Open Spline

1. Pick **Open** in **INTPOL SPL** or in **CONTRL SPL**.
2. Pick a sequence of points.
3. Press **END**.

Creo Elements/Direct Drafting draws an open spline curve through the points you specified. This is the default. If you do not specify Open or Closed, an open spline is drawn.

Drawing a Closed Spline

1. Pick Closed in INTPOL SPL or in CONTRL SPL.
2. Pick a sequence of points.
3. Press **END**.

Creo Elements/Direct Drafting draws a closed spline curve through the points you specified.

Appending a Spline

You can append or blend a spline curve to existing geometry.

1. Pick INTPOL SPL
2. Pick Append in OPTIONS.
3. Pick the end-point of the line you want to append.
4. Pick a sequence of points.
5. Press **END**.

To append the begin-point and end-point of a spline, do the following:

1. Pick **INTPOL SPL**
2. Pick **Append** in **OPTIONS**.
3. Pick point A and a series of points B1, B2, B3, ..., Bn.
4. Pick **Append** in **OPTIONS**.
5. Pick point C.
6. Press **END**.

Figure 64. Appending a Spline

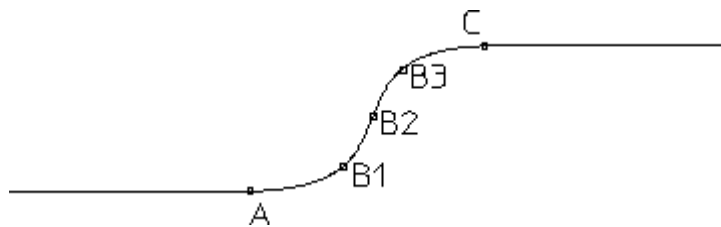

Changing the Order of a Spline

The spline order controls the smoothness of the curve. The higher the order, the smoother the spline. [Figure 65. Spline Order on page 146](#) shows two splines drawn through the same control points.

Figure 65. Spline Order

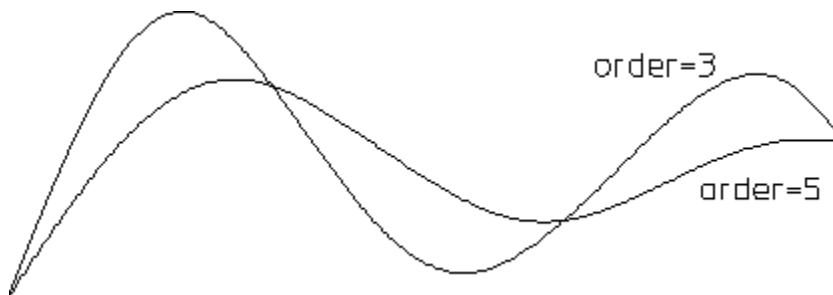

To change the order of a spline:

1. Pick **Order** in **INTPOL SPL** or in **CONTRL SPL**.
2. Enter a number between 3 and 10.
3. Pick a sequence of points.
4. Press **END**.

Specifying the Angle of a Spline

You can use the Tangent option to specify the angle at which the spline leaves or approaches a point. For example, to specify an angle of 70°:

1. Pick **INTPOL SPL**.
2. Pick the first interpolation point (A in [Figure 66. Specifying the Angle of a Spline on page 147](#)).
3. Pick Tangent in **INTPOL SPL**.
4. Type in 70 and press [Enter].

You can also pick a point at the required angle, for example, point C.

5. Pick the second point (B in [Figure 66. Specifying the Angle of a Spline on page 147](#)).
6. Press **END**.

Figure 66. Specifying the Angle of a Spline

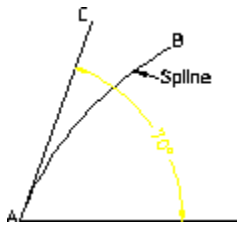
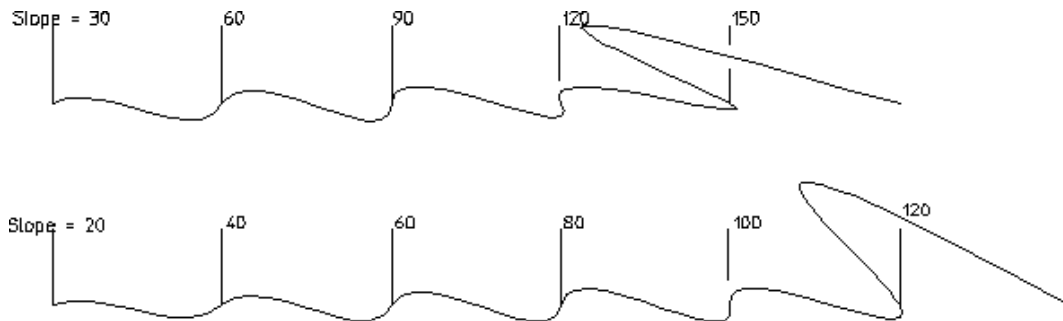
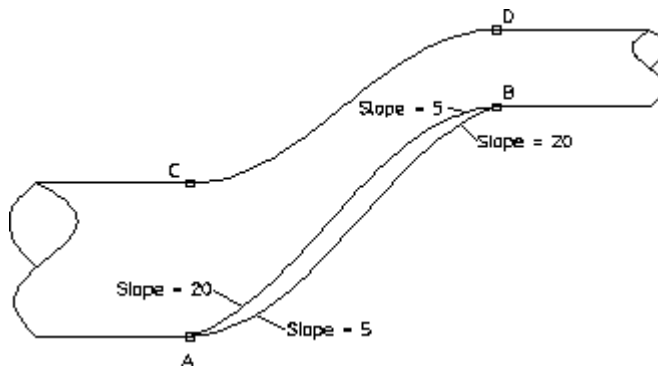

Figure 67. Effects of Different Angles on page 147 shows the effects of specifying different angles:

Figure 67. Effects of Different Angles



Being able to specify the slope of a spline is useful when joining unequal diameters. The following diagram shows the difference between curves created with the Append option (curve CD) and the Tangent option (curve AB).



To draw curve C to D, do the following:

1. Pick **INTPOL SPL**.
2. Pick **Append** in **OPTIONS**.
3. Pick point C.
4. Pick **Append** in **OPTIONS**.
5. Pick point D and then press **END**.

To draw the lower curve A to B, do the following:

1. Pick **INTPOL SPL** and pick point A.
2. Pick **Tangent** in **OPTIONS**.
3. Enter 5.
4. Pick point B.
5. Pick **Tangent** in **OPTIONS**.
6. Enter 20 and then press **END**.

Modifying Splines

You can modify the shape of a spline using the following commands:

CHG I PNT	Lets you change the position or tangent of an interpolation point. With this command, the basic shape of the spline changes—see Figure 69. Effects of CHG I PNT and CHG PNT on page 148.
CHG C PNT	Lets you change the position of a control point. In this case, the control polygon must be visible.
CHG PNT	Lets you change the position of a spline. With this command, the basic shape remains the same—see Figure 69. Effects of CHG I PNT and CHG PNT on page 148.

[Figure 69. Effects of CHG I PNT and CHG PNT on page 148](#) shows the effects of the commands CHG I PNT and CHG PNT.

Figure 69. Effects of CHG I PNT and CHG PNT

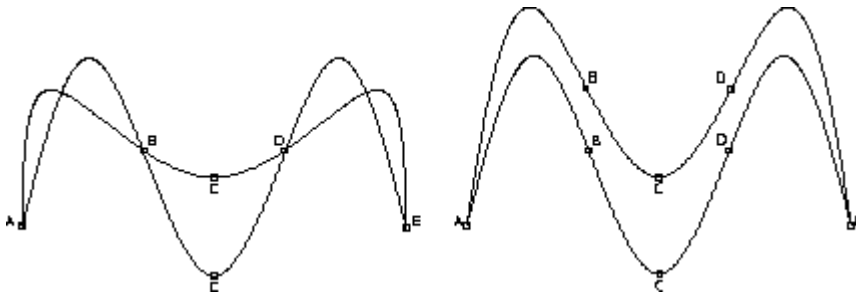

The splines on the left were created as follows:

1. Pick **CHG I PNT**.
2. Identify the spline.
3. Pick point C.
4. Move point C up the screen.

The spline curve continues to pass through the interpolation points at B and D.

To create the splines on the right, follow the previous procedure but use the command CHG PNT. In this case, the general shape of the spline is retained because the interpolation points B and D also move.

Table 3 on page 149 lists some advantages and disadvantages of using the commands CHG I PNT, CHG PNT, and CHG C PNT.

Table 3

When to use CHG I PNT, CHG PNT, or CHG C PNT

	Advantages	Disadvantages
CHG I PNT	<p>The whole spline shape is recomputed.</p> <p>When you move the position of an interpolation point, the position of the other interpolation points remains.</p>	<p>You can pick interpolation points only. You cannot pick arbitrary points.</p> <p>This command works for splines created by specifying interpolation points only. The spline curve gets a rippling effect.</p>
CHG PNT	<p>The shape of the spline curve is retained and you do not get a rippling of the curve.</p> <p>You can pick an arbitrary position, for example, between two interpolation points.</p> <p>This command works for splines created by specifying control points and for splines created by specifying interpolation points.</p>	<p>The positions of all interpolation points change.</p>
CHG C PNT	<p>The whole spline shape is recomputed without the rippling effect produced when using CHG I PNT.</p> <p>This command works for splines created by specifying control points and for splines created by specifying interpolation points.</p>	<p>The positions of all interpolation points change.</p>

Changing the Position of Points

You can change the position of interpolation points and control points.

Interpolation Points

To change the position of interpolation points on a spline:

1. Pick **CHG I PNT**.
2. Identify the spline you want to modify.
3. Pick the interpolation point you want to move.
4. Pick the new position of the interpolation point.

When you move an interpolation point, the shape of the spline changes accordingly.

Control Points

To change the position of control points on a spline:

1. Pick **CHG C PNT**.
2. Identify the spline you want to modify.
3. Pick the control point you want to move.
4. Pick the new position of the control point.

When you move a control point, the shape of the spline changes accordingly.

Adding Points

You can add additional interpolation points and control points.

Interpolation points

To add a new interpolation point on a spline:

1. Make sure the interpolation points are visible; press **SHOW POINTS**
2. Pick **ADD I PNT**.
3. Identify the spline you want to add points to.
4. Pick a point on the spline.
5. Pick again to place the point.

When you add an interpolation point, the shape of the spline changes accordingly.

Control Points

To add a new control point on the control polygon, do the following:

1. Pick **ADD C PNT** and identify the spline.
2. Pick a point between two control points.
3. Pick a point where you want to insert the new control point (point C).

Figure 70. Adding a Control Point

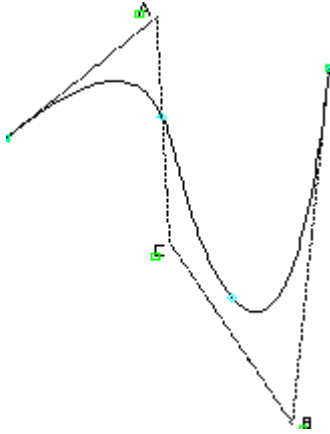

When you add a control point, the shape of the spline changes accordingly.

Deleting Points

You can delete interpolation points and control points.

Interpolation points

To delete an interpolation point on a spline:

1. Make sure the interpolation points are visible; press **SHOW POINTS**
2. Pick **DEL I PNT**.
3. Identify the spline you want to delete points from.
4. Pick the interpolation point you want to delete.

When you delete an interpolation point, the shape of the spline changes accordingly.

Control Points

To delete a control point from a control polygon:

1. Pick **DEL C PNT**.
2. Identify the spline you want to delete points from.
3. Pick the control point you want to delete.

When you delete a control point, the shape of the spline changes accordingly.

Modifying the Angle of a Spline

You can specify the angle at which a spline approaches an interpolation point. This is useful if you are merging a spline into another line. [Figure 71. Effect of Changing the Angle at an Interpolation Point on page 152](#) shows a simple spline and the same spline with the tangent of interpolation point A changed.

Figure 71. Effect of Changing the Angle at an Interpolation Point

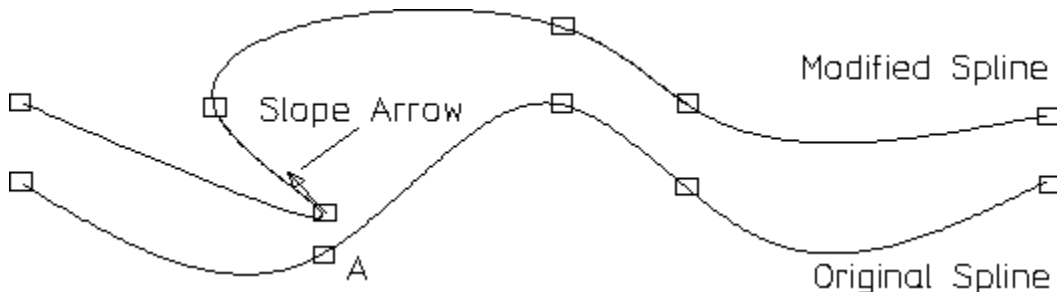

The Tangent option applies to interpolation points only. You cannot change the tangent of a control point.

To change the slope of an interpolation point:

1. Make sure the interpolation points are visible; use the **SHOW** menu.
2. Pick **CHG I PNT**.
3. Pick **Tangent**.
4. Identify the spline.
5. Pick the interpolation point where you want to change the slope.

Creo Elements/Direct Drafting displays an arrow to indicate the direction of the slope. The original shape remains until you pick the desired point.

With the **DEL TANGENT** command, you can delete tangents at interpolation points. Pick **DEL TANG** and then pick the interpolation point. Creo Elements/Direct Drafting deletes the tangent of the selected point and reshapes the spline according to the remaining points.

More About Interpolation Splines and Control-Point Splines

You can create splines based on interpolation points or control points. If you want a spline to pass through defined points, use interpolation points. If the spline does not need to pass through defined points, you can use interpolation-point created splines or control-point created splines. Control-point created splines are more appropriate for creative design work where curved molded surfaces are required. [Figure 72. Interpolation-Point Splines \(I\) versus Control-Point Splines \(C\) on page 153](#) and [Table 4. Interpolation-Point Splines versus Control-Point Splines on page 153](#) show the differences, particularly when you want to modify a spline.

Figure 72. Interpolation-Point Splines (I) versus Control-Point Splines (C)

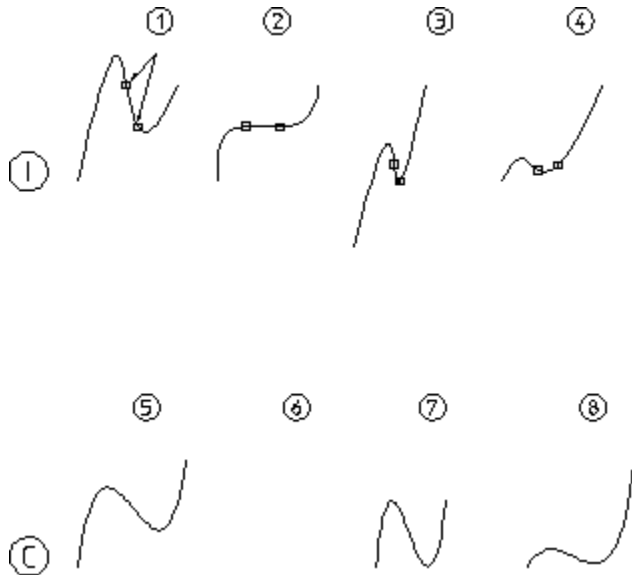

Table 4. Interpolation-Point Splines versus Control-Point Splines

Type	CHG I PNT	CHG PNT	CHG C PNT
Interpolation (Splines I)	Spline 2	Spline 3	Spline 4
Control (Splines C)	Position 6 is empty because a spline created by control points does not have interpolation points.	Spline 7	Spline 8

Converting Splines

Splines only need converting if you want to export them to devices (such as numerical control machines) that do not recognize spline curves.

Splines can be converted to arcs and lines using the **CONVERT** menu. This menu contains the following commands:

Arcs & Lines	Use this option to convert splines to arcs and lines.
Lines	Use this option to convert splines to lines.

Splitting Splines

Splines can be split in the same way as other line elements. However, you can set a TRIMMING function that affects the way in which a spline is split. The TRIMMING function has the options:

On	Two new (independent) splines are created, each with their own mathematical behavior.
Off	The visibility range of the spline is reduced. This means that the spline is drawn from the start (respectively end) point to the split point. Curve points beyond the visibility range are kept but are not visible.

Figure 73. Splitting Splines on page 154 shows the effects of splitting a spline with TRIMMING:

On	Splines 2A and 2B The spline is split in two—with each spline having a new end-point, a new start-point, and individual control polygons.
Off	Splines 3A and 3B The spline is split but the control polygon remains the same shape. When the left part of the spline is deleted, the curve points are retained (although they are invisible).

Figure 73. Splitting Splines

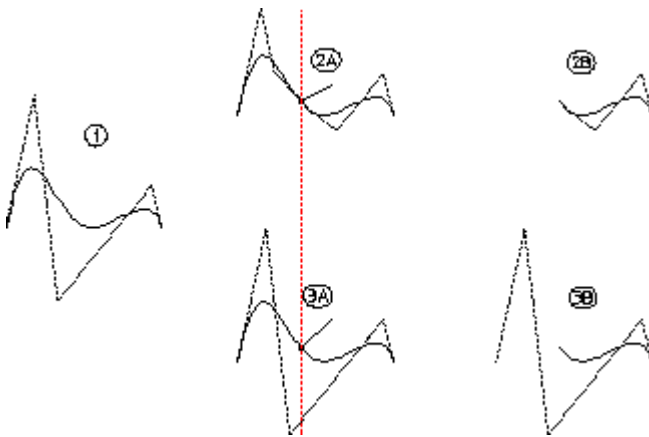

In drawings 2B and 3B, the left spline has been deleted. Notice in drawing 3B how the control polygon thinks that the spline starts at its original point (drawing 1).

To use the TRIMMING command:

1. Pick **On** (or **Off**) in **TRIMMING**.
2. Pick **Elem / Box** in **SPLIT**.

3. Identify the element.
4. Pick point where spline should be split.

Dividing a Spline

The SUBDIV SPL command divides a spline into equal lengths.

Dividing splines into equal lengths is useful, for example, when designing the shape of a ship's hull and you need to divide the ribs (rib-cage) into equal lengths.

You can tell Creo Elements/Direct Drafting to calculate equal segments or specify segments by picking points.

Figure 74. Dividing a Spline

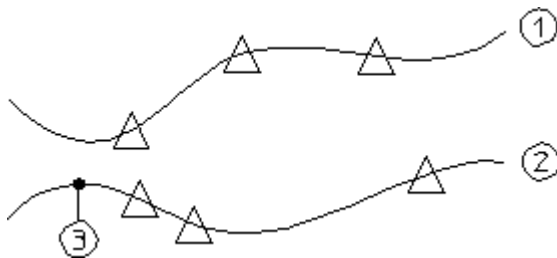

To divide a spline into equal segments (spline 1):

1. Pick SUBDIV SPL in the **CREATE** menu.
2. Identify the spline.
3. Enter a value for the number of segments you want (for example, 4).

Creo Elements/Direct Drafting divides the spline into 4 equal lengths.

To divide a spline by specifying points (spline 2):

1. Draw a spline (covering about 40 mm of horizontal workspace).
2. Pick SUBDIV SPL in the **CREATE** menu.
3. Identify the spline.
4. Pick a point 3 on the spline.
5. Enter the values: 5 10 30.

Creo Elements/Direct Drafting inserts a marker at distances of 5 mm, 10 mm, and 30 mm from point 3. If the specified distance is outside that of the spline, Creo Elements/Direct Drafting does not insert a marker. Markers are inserted in the same direction that the spline was created. If you enter negative values (for example, -5, -10), markers are inserted in the opposite direction.

Example — Cam Profile

This example describes how to create a cam profile and then modify it.

Construct the following geometry (see [Figure 75. Cam Profile - 1](#) on page 156):

- Horizontal and vertical lines at 0 0
- Circles at 35 40 45
- Lines at angles 30 60 120 150

Figure 75. Cam Profile - 1

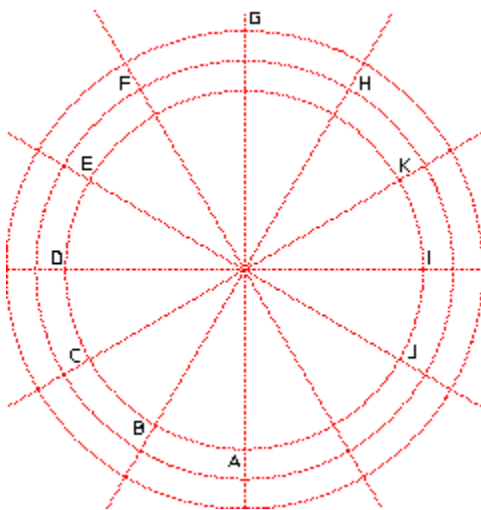

To create the initial profile:

1. Press **CREATE**.
2. Pick **SPLINE**.
3. Pick **INTPOL SPL**.
4. Pick **Closed**.
5. Pick points A, B, ... J.
6. Press **END**.

Figure 76. Cam Profile - 2

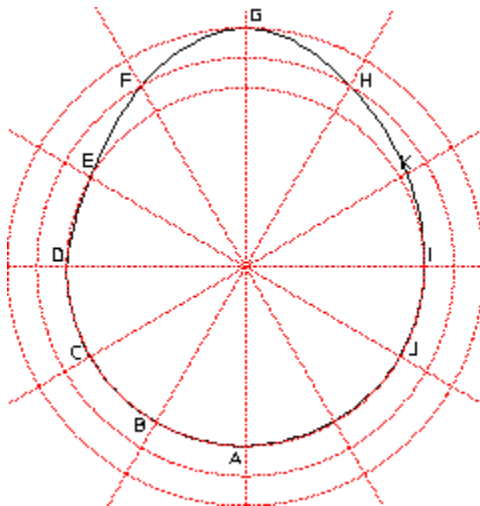

You now want to add an interpolation point at K:

1. Pick **ADD I PNT**
2. Pick the spline.
3. Pick a point on the spline that is close to the point K.
4. Pick the intersection point at K.

Figure 77. Cam Profile - 3

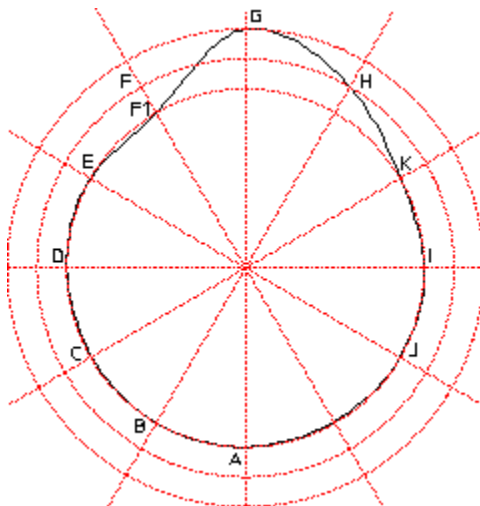

To delete and interpolation point:

1. Pick **DEL I PNT**
2. Pick the spline.
3. Pick point C.

The system deletes the point.

To change the position of an interpolation point:

1. Pick **CHG I PNT**.
2. Pick **Position**.
3. Pick the spline.
4. Pick point F.
5. Move the point and pick point F1.

To change the angle at point F1:

1. Pick **CHG I PNT**.
2. Pick **Tangent**.
3. Pick the spline.
4. Pick point F1.

The system displays an arrow indicating the slope direction. You can now either pick a point to indicate the direction or enter a value. (This example uses an angle of 10°.)

5. Enter 10

Figure 78. Cam Profile - Final Shape

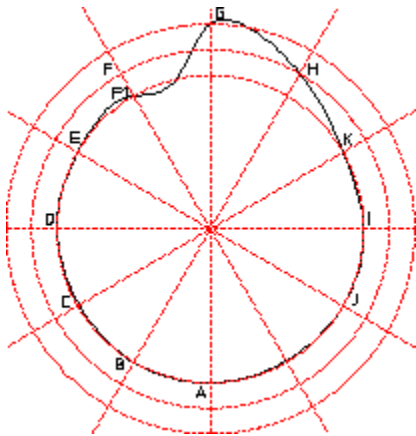

Drawing Parallel Contours

To create an equidistant or parallel contour.

1. Press **CREATE**.
2. Pick **EQUIDIST**.
3. Enter the separation required for the parallel contour.

-
4. Identify the start point of the existing contour.
 5. Indicate the elements to be copied (Creo Elements/Direct Drafting will allow you to skip to the final element, provided you do not pass more than one branch element that is not to be copied).
 6. Indicate the side on which the parallel contour is to be drawn.

If you require a particular section of a contour to be copied:

1. Follow steps 1 to 5 above.
2. When you have indicated the desired section, press **END**.
3. Indicate the side on which the parallel contour is to be drawn.

7

Modifying a Drawing

Modifying Using Selection	162
Moving Elements.....	162
Rotating Drawings	164
Mirroring Drawings	165
Making Elements Larger or Smaller	167
Drawing Similar Elements	168
Creating a Parallel Perspective (Oblique) View	168
Stretching a Drawing	170
Drawing an Isometric View.....	171
Trimming Elements.....	172
Creating a Contour	174
Cleaning a Drawing	175
Further Information.....	179

This chapter shows you how to use the commands and options that allow you to reposition or alter your drawing.

You can modify single drawing elements for example, lines and circles, or enclose the elements you want to modify in a box.

For all modification commands/options (except ISOMETRIC) you must first pick Keep or No Keep in **MODIFY**. This determines whether the original drawing elements will be kept or deleted after the modification. For example, picking MOVE with Keep copies the drawing elements concerned rather than just moving them.

If you attempt to pick a modification command before Keep or No Keep, Creo Elements/Direct Drafting will beep to indicate an error.

To modify a different set of elements, first pick Keep or No Keep, otherwise the previously selected elements will still be active.

After picking Keep or No Keep in STRETCH, you can pick any of the **MODIFY** options. The result will be a combination of STRETCH and the other modify option chosen.

For a description of the PIXMAP command, see [Importing a Bitmap File on page 471](#).

Modifying Using Selection

The **SELECTION** mechanism described in [Commonly Used Commands on page 35](#) can also be used with all the **MODIFY** commands/options, (except ISOMETRIC and STRETCH).

Using **SELECTION** gives you various ways to identify elements to be modified and to see them highlighted on the screen before a modification is made.

To use **SELECTION** with **MODIFY**:

1. Press **MODIFY**.
2. Press Keep or No Keep in **MODIFY**
3. Identify the elements to be modified using the options available in the **SELECTION** block.
4. Press **CONFIRM**
5. Select the appropriate modification option.

Note

If you are using a parts structure in your drawing, the selection of elements to be modified is slightly different; refer to [Handling Parts and Assemblies on page 372](#) for details.

The GLOBAL option of the selection mechanism (described in

[Commonly Used Commands on page 35](#)) can be used in conjunction with the STRETCH command.

Moving Elements

Pick **MOVE** to move or copy drawing elements to another position.

Pick **MOVE** with Keep to produce a copy. The original remains unchanged.

MOVE 2 Pts is the default modification option and is available as soon as you select Keep or No Keep in **MODIFY**.

After selecting Keep or No Keep you can enter a repeat factor. This will repeat the next operation you select the specified number of times.

By Reference Point

To move or copy a drawing element(s) using a reference point:

1. Press **MODIFY**.

-
2. Pick No Keep (or Keep) in **MODIFY**.
 3. Identify one drawing element or enclose several in a box.
 4. Pick **2 Pts** in **MOVE**.
 5. Indicate a reference point on the element(s) you have selected.
 6. Indicate the new position for the reference point.

Creo Elements/Direct Drafting moves the element(s) to the new position.

Horizontal Move/Copy

To move or copy a drawing element(s) to a new position in the horizontal direction:

1. Press **MODIFY**.
2. Pick No Keep (or Keep) in **MODIFY**.
3. Identify one drawing element or enclose several in a box.
4. Pick Horizontal in **MOVE**.
5. Enter the required horizontal distance.

If a repeat factor has been specified then the same horizontal distance will be taken for each move or copy.

Note

You can interrupt the command with the MEASURE LENGTH function if the distance you need can be measured from existing features on the drawing. Alternatively, you can indicate two points defining the horizontal distance required.

Vertical Move/Copy

To move or copy a drawing element(s) to a new position in the vertical direction:

1. Press **MODIFY**.
2. Pick **No Keep** (or Keep) in **MODIFY**.
3. Identify one drawing element or enclose several in a box.
4. Pick **Vertical** in **MOVE**.
5. Enter the required vertical distance.

If a repeat factor has been specified then the same vertical distance will be taken for each move or copy.

Multiple Move/Copy

To repeatedly move or copy a drawing element(s) to any new position required:

1. Press **MODIFY**.
2. Pick **No Keep** (or **Keep**) in **MODIFY**.
3. Identify one drawing element or enclose several in a box.
4. Pick **Multiple** in **MOVE**.
5. Indicate a reference point on the drawing or elements.
6. Indicate as many destination points as required.
7. Terminate the move or copy by picking another command, another option, or pressing **END**.

Rotating Drawings

Two commands let you rotate your drawing. Both can be used with either **Keep** or **No Keep** in **MODIFY**.

About a Center

To rotate a drawing or drawing element about a center:

1. Press **MODIFY**.
2. Pick **No Keep** (or **Keep**) in **MODIFY**.
3. Identify one drawing element or enclose several in a box.
4. Pick **Center** in **ROTATE**.
5. Indicate the center of rotation.
6. Enter the angle of rotation. Alternatively, you can define the angle by indicating two points.

A positive angle causes a counterclockwise rotation.

The Center option is especially useful when combined with a repeat factor for repeated rotation. The flywheel shown in [Figure 79. Flywheel on page 165](#) was drawn by rotating the holes with a repeat factor of 5.

Figure 79. Flywheel

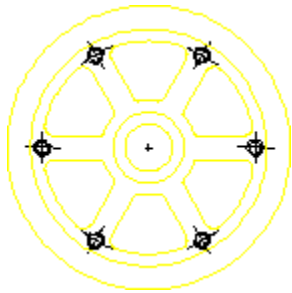

By Reference Point

To rotate a drawing or drawing element using a reference point:

1. Press **MODIFY**.
2. Pick **No Keep** (or **Keep**) in **MODIFY**.
3. Identify one drawing element or enclose several in a box.
4. Pick **2 Pts** in **ROTATE**.
5. Indicate a rotation reference point on the drawing or element.
6. Indicate the destination for the rotation reference point.
7. Enter the angle of rotation. Alternatively, you can define the angle by indicating two points.

A positive angle causes a counterclockwise rotation.

Mirroring Drawings

To save time when drawing symmetrical shapes you can mirror them about a line of symmetry.

MIRROR is usually used with **Keep** in **MODIFY**, the repeat factor is set to 1.

Wait until your drawing is nearly complete before mirroring, otherwise you may miss a feature and have to draw it in both halves.

About Two Points

This option is the default.

To mirror a drawing about two points:

1. Press **MODIFY**.
2. Pick **Keep** in **MODIFY**.
3. Enclose the drawing elements to be mirrored in a box.

4. Pick **2 Pts** in **MIRROR**.
5. Indicate two points on the line of symmetry.

The line of symmetry in [Figure 80. Line of Symmetry](#) on page 166 is the dashed line.

Figure 80. Line of Symmetry

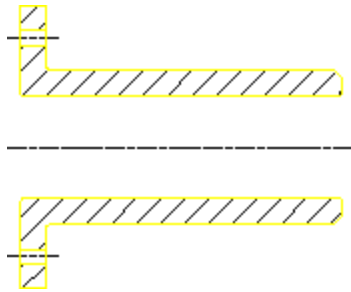

About the Horizontal

To mirror a drawing about the horizontal:

1. Press **MODIFY**.
2. Pick **Keep** in **MODIFY**.
3. Enclose the drawing elements to be mirrored in a box.
4. Pick **Horizontal** in **MIRROR**.
5. Indicate a point on the horizontal line of symmetry.

About the Vertical

To mirror a drawing about the vertical:

1. Press **MODIFY**.
2. Pick **Keep** in **MODIFY**.
3. Enclose the drawing elements to be mirrored in a box.
4. Pick **Vertical** in **MIRROR**.
5. Indicate a point on the vertical line of symmetry.

About a Center Point

To rotate a drawing through 180 degrees:

1. Press **MODIFY**.
2. Pick **Keep** in **MODIFY**.

-
3. Enclose the drawing elements to be rotated in a box.
 4. Pick **Center** in **MIRROR**.
 5. Identify a point for rotation.

The elements will be rotated 180 degrees in a clockwise direction.

Making Elements Larger or Smaller

Pick **SCALE** to make drawing elements and text larger or smaller. Note that dimensions will be changed accordingly. If you want to keep the original drawing elements, select Keep in **MODIFY**.

By Center

When drawing elements are scaled using the Center option, one point on the drawing remains fixed.

To scale your drawing using Center:

1. Press **MODIFY**.
2. Pick **Keep** (or No Keep) in **MODIFY**.
3. Enclose the drawing elements to be scaled in a box.
4. Pick **Center** in **SCALE**.
5. Indicate the fixed point.
6. Enter the scale factor (for example, 0.5).

Instead of entering a scale factor, you can identify a point and then indicate the new position of this point. The drawing elements will then be scaled accordingly.

By Reference Point

To scale your drawing using a reference point:

1. Press **MODIFY**.
2. Pick **Keep** (or No Keep) in **MODIFY**.
3. Enclose the drawing elements to be scaled in a box.
4. Pick **2 Pts** in **SCALE**.
5. Identify a reference point.
6. Indicate the new position for this point.
7. Enter the required scale factor.

The selected elements will now be moved and scaled.

Drawing Similar Elements

The **SIMILAR** option is a combination of the **MOVE**, **ROTATE** and **SCALE** options. It allows you to fit specified drawing elements between two given points. This involves rescaling.

To fit a specified drawing element between two given points:

1. Press **MODIFY**.
2. Pick **Keep** (or No Keep) in **MODIFY**.
3. Enclose the drawing elements in a box.
4. Identify two reference points on the drawing.
5. Indicate two destination points for those reference points.

The drawing elements will then be scaled to fit the new position. [Figure 81. Fitting Drawing Elements Between Two Points on page 168](#) shows an example.

Figure 81. Fitting Drawing Elements Between Two Points

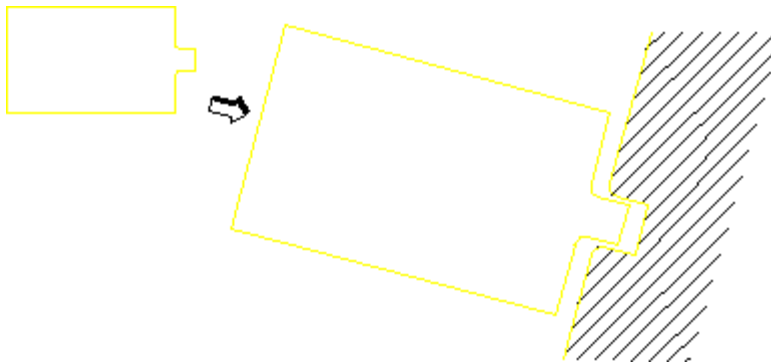

Creating a Parallel Perspective (Oblique) View

Pick **TRANSFORM** to create a parallel perspective view.

Parallel perspective means that three view points for the perspective view are taken to be at infinity, and parallel lines will therefore remain parallel.

Example

[Figure 82. Creating an Oblique View on page 169](#) shows an oblique view created by copying the end elevation, then using the **TRANSFORM** command to create the side and top.

Points used for the first **TRANSFORM** operation are shown.

Figure 82. Creating an Oblique View

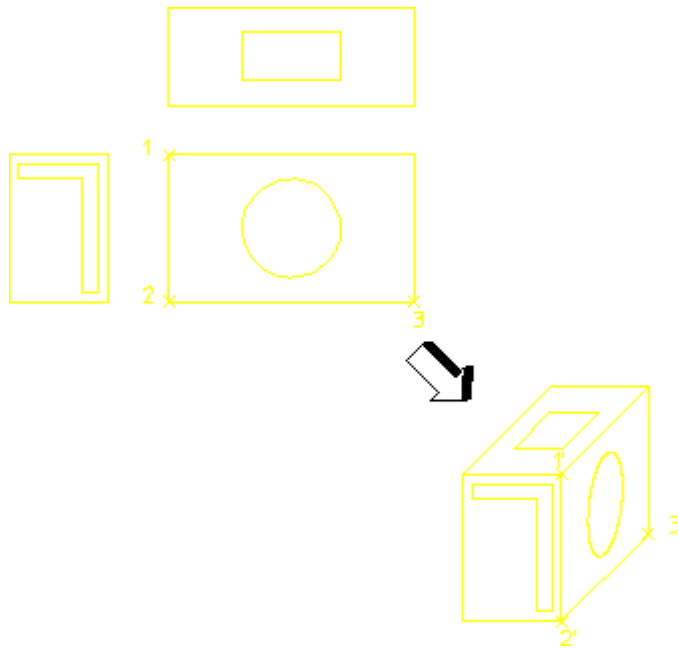

Position the End View

1. Press **MODIFY**.
2. Pick **Keep** in **MODIFY**.
3. Identify the end view by enclosing it in a box.
4. Pick **2 Pts** in **MOVE**.
5. Identify a reference point on the drawing (end view).
6. Indicate a destination point.

Position the Side View

1. Pick **Keep** in **MODIFY**.
2. Identify the side view by enclosing it in a box.
3. Pick **TRANSFORM**.
4. Identify three reference points on the drawing (1, 2, and 3).
5. Indicate the three destination points on the oblique view (1, 2, and 3).

Position the Top View

1. Pick **Keep** in **MODIFY**.
2. Identify the top view by enclosing it in a box.
3. Pick **TRANSFORM**.

4. Identify three reference points on the drawing.
5. Indicate the three destination points on the oblique view.

Stretching a Drawing

Alter the shape of your drawing by stretching it in a certain direction. All the dimensioning, hatching, and finishing information will be modified to fit the new stretched shape.

Example

The following example shows how to use the **STRETCH** command. Refer to [Figure 83. Stretching a Drawing on page 170](#).

Figure 83. Stretching a Drawing

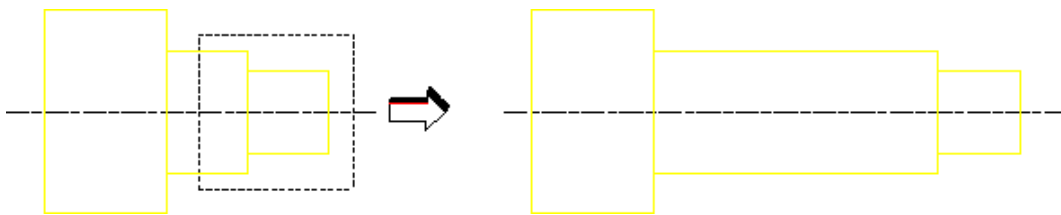

1. Press **MODIFY**.
2. Pick **Keep** or **No Keep** in **STRETCH** (in most cases you will use the No Keep option).
3. Identify the elements to be stretched. You can identify the elements by identifying a single vertex or boxing several (the vertex is moved and the element stretched accordingly).

The default in **STRETCH** is **2 Pts**.

4. Identify a reference point on the drawing.
5. Indicate a destination point.

You can combine stretching with any of the other modify commands (except **ISOMETRIC**).

Example

1. Pick **Keep** or **No Keep** in **STRETCH**.
2. Pick the required command.
3. Identify the drawing elements to be modified.

Horizontally

To stretch your drawing horizontally:

1. Pick **Keep** or **No Keep** in **STRETCH**.
2. Identify the elements of the drawing to be stretched.
3. Pick **Horizontal**.
4. Enter a distance and the stretch will be performed accordingly. Alternatively, identify two points to define the distance.

Vertically

To stretch your drawing vertically:

1. Press **MODIFY**.
2. Pick **Keep** or **No Keep** in **STRETCH**.
3. Identify the elements of the drawing to be stretched.
4. Pick **Vertical**.
5. Enter a distance and the stretch will be performed accordingly. Alternatively, identify two points to define the distance.

Note

You can interrupt the command by pressing **LENGTH** in **MEASURE**, if the distance you need can be measured from existing features on the drawing.

Drawing an Isometric View

To draw an approximate isometric view of a three-dimensional object, you must have drawn the front, side, and top views already.

The following example shows how to create an isometric view. Refer to [Figure 84. Creating an Isometric View on page 172](#).

Figure 84. Creating an Isometric View

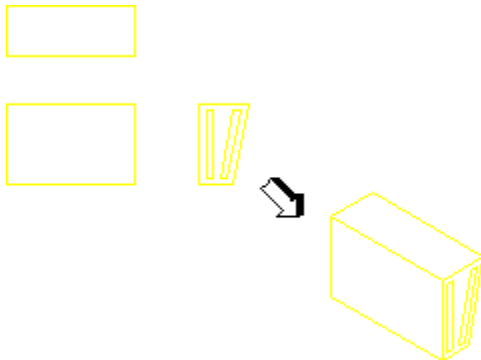

1. Press **MODIFY**.
2. Pick **ISOMETRIC**.
3. Identify the front view by enclosing it in a box.
4. Identify a reference point on the front view.
5. Indicate the destination for the front view reference point.
6. Identify the side view by enclosing it in a box.
7. Identify a reference point on the side view.
8. Indicate the destination for the side view reference point.
9. Identify the top view by enclosing it in a box.
10. Identify a reference point on the top view.
11. Indicate the destination for the top view reference point.

Trimming Elements

Overlapping elements can easily be trimmed or extended with the **TRIM EXTND** command. This is useful when you want to clean up a drawing. Note that construction geometry can be used as reference elements (indicating where an element is to be trimmed).

Trimming One Element

The Trim One option trims one overlapping element.

To trim one overlapping element:

1. Pick Trim One in the **MODIFY** menu.
2. Identify the first element (point 1).
3. Identify the intersecting element (point 2).

Figure 85. Trimming One Element

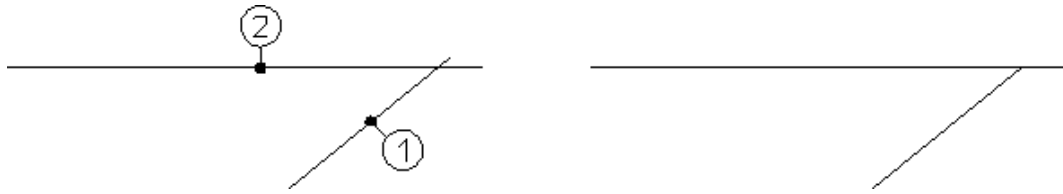

Trimming Two Elements

The **Trim Two** option trims two overlapping elements.

To trim two overlapping elements:

1. Pick **Trim Two** in the **MODIFY** menu.
2. Identify the first element (point 1).
3. Identify the intersecting element (point 2).

Figure 86. Trimming Two Elements

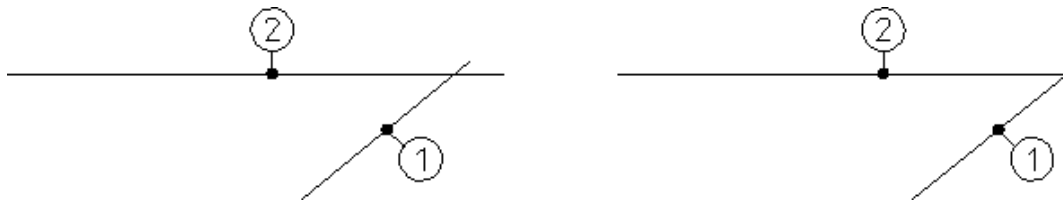

Use the option **CHAIN** if you are trimming a series of elements. After you pick the second element, Creo Elements/Direct Drafting trims the line(s) and tells you to pick the next element:

1. Pick Trim One
2. Pick Chain
3. Pick point 1
4. Pick point 2
5. Pick points 3, 4, 5, 6

Figure 87. Using the CHAIN Option



 **Note**

You cannot trim elements such as closed splines, circles, and closed polygons because split points are not defined.

Cutting Out the Middle Section

The **Cut Middle** option cuts the middle section out of intersecting elements.

To cut out the middle of an element:

1. Pick **Cut Middle** in the **MODIFY 2** menu.
2. Identify element (point 1)
3. Identify element (point 2)
4. Identify element (point 3)

The option **CHAIN** takes the last intersecting elements as the new intersecting elements.

Figure 88. Cutting Out the Middle Section

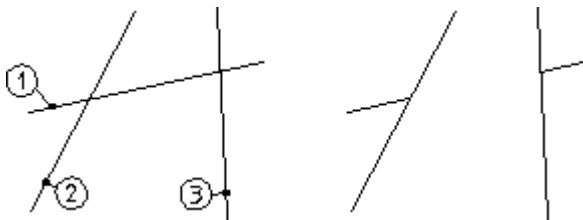

Creating a Contour

The **CONTOUR** command creates a smooth contour by deleting overlapping elements.

To create a contour from a number of overlapping lines:

1. Pick **CONTOUR** in the **MODIFY 2** menu.
2. Enclose the elements in a box.

Figure 89. Creating a Contour

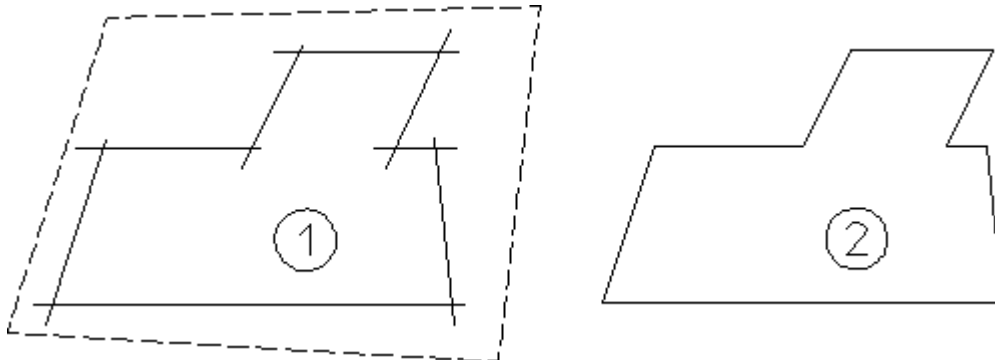

Cleaning a Drawing

Inconsistencies in a part (for example, lines not quite parallel, small gaps between tangent objects, duplicate elements) are relatively common, but can cause problems for applications (like Parametric Design) that scan the part to extract information. To help eliminate drawing inconsistencies, Creo Elements/Direct Drafting provides several tools that can do limited cleaning of parts. The **CLEAN** commands are:

- Points
- Duplicate
- Stacked
- Staggered
- Gaps

Points

Model points within a given distance of each other are merged, and the elements attached to the merged points are adjusted (moved, stretched, or rotated) as necessary to reflect the new positions of the points. For each set of points to be merged, Points chooses a location within the given tolerance and moves the points there. In general, there is no way to accurately predict or control which elements will be adjusted as a result of the merge. This should not be a limitation in most cases, however, because the tolerance used is likely to be small. Points is most useful for removing small gaps between elements. To use Points:

1. Pick Points in the **MODIFY 2** menu.
2. Enter a distance tolerance (current length units).
3. Points within the given tolerance are marked with a *, and will be merged. Elements that will be modified as a result of the merge are highlighted.

-
4. Press **CONFIRM** to merge the marked points and modify the highlighted elements.

Duplicate

Duplicate scans the part for duplicate elements and deletes them. The command selects which element of a duplicate pair to delete. Elements are considered to be duplicates if their model points are identical. An exception is made for concentric circles (only): if the radii of concentric circles are within a given tolerance, they are treated as duplicates. Normally, Duplicate should be used after Points to clean up duplicate elements that may result from merging model points. To use Duplicate:

1. Pick **Duplicate** in the **MODIFY 2** menu.
2. Enter a distance tolerance (current length units) for concentric circles.
3. Elements that will be deleted are highlighted.
4. Press **CONFIRM** to remove duplicate elements.

Stacked

Stacked finds stacked lines and arcs in the current part and calls SPLIT to split them. To use Stacked:

1. Pick **Stacked** in the **MODIFY 2** menu.
2. Elements to be split are highlighted and the points to be used for the splits are marked with a *.
3. Press **CONFIRM** to split elements.

Note

Tip: To clean up most common problems in a part, run the CLEAN commands in the following sequence:

Points	Merge disconnected points.
Duplicate	Remove existing duplicates and those caused by merging points.
Stacked	Split overlapping elements.
Duplicate	Remove duplicates caused by splitting.

Staggered

Staggered finds staggered (partially overlapping) lines and arcs in the current part and merges these to form a single "new" line or arc. The "old" lines or arcs are removed by this operation. To use Staggered:

1. Pick **Staggered** in the **MODIFY 2** menu.
2. Enter a distance tolerance (current length units).
3. Elements that will be deleted are highlighted.
4. Press Confirm to delete superfluous elements following the merge.

Gaps

Gaps uses the Creo Elements/Direct Drafting **TRIM EXTND** functionality to close "trivial" gaps between two or more elements, even between circular and linear elements.

- "Trivial" gaps are small gaps that can be closed automatically without any major impact on the drawing. These can be closed automatically.
- "Non-trivial" gaps cannot be eliminated automatically because their elimination may lead to unpredictable results. Therefore, "non-trivial" gaps cannot be closed automatically. "Non-trivial" gaps are typically characterized by distances and/or complexities greater than those found in "trivial" gaps.

To automatically close "trivial" gaps:

1. Press Gaps in the **MODIFY 1** menu.
2. Draw a selection box around the elements between which there are gaps that you want to close. Note that, if you use the **Global** selection mode, you may unintentionally close "correct" gaps between elements.
3. Enter a distance tolerance (in current length units). Note that this distance tolerance needs to be a "realistic" (small) value in order to prevent the elimination of required spacing between elements. If the distance tolerance is too big, a very large number of gaps may be shown. If all gaps are shown in the drawing, your drawing may be cluttered with color rectangles indicating "non-trivial" gaps.

The number of "trivial" and "non-trivial" gaps found in your selection is indicated in the prompt line. However, note that "non-trivial" gaps are not indicated in the drawing.

4. Be sure to check the "trivial gaps" preview for plausibility.
5. Press **CONFIRM** to close any "trivial" gap(s).

Figure 90 on page 160 shows an example of a set of elements separated by "trivial" gaps. These gaps are highlighted in the drawing and are then closed. Note that the gap sizes are exaggerated for visual clarity.

Figure 90. Closing Trivial Gaps

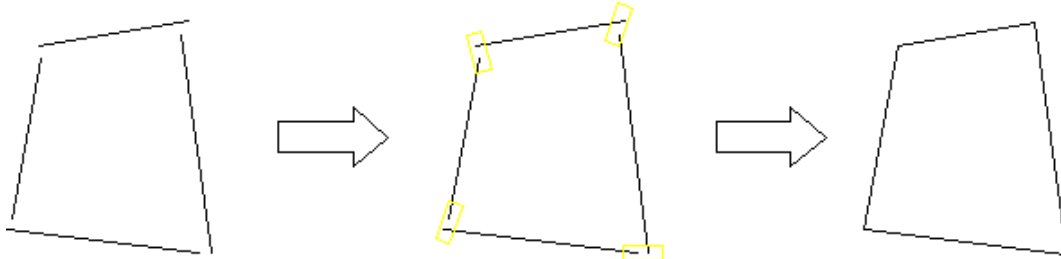

Show Gaps

Show Gaps can be used to box "non-trivial" gaps between two or more elements.

To mark "non-trivial" gaps:

1. Press **Show Gaps** in the **MODIFY 1** menu.
2. Select a box color for "trivial" gaps.
3. Select a box color for "non-trivial" gaps.
4. Draw a selection box around the elements between which there are or may be gaps.
5. Enter a distance tolerance (current length units). Note that this distance tolerance needs to be a "realistic" (small) value in order to prevent the elimination of required spacing between elements. If the distance tolerance is too big, a very large number of gaps may be shown. If all gaps are shown in the drawing, your drawing may be cluttered with color rectangles indicating "non-trivial" gaps.

The number of "trivial" and "non-trivial" gaps found in your selection is indicated in the prompt line.

6. Enter the number of "non-trivial" gaps.

Optionally, by incrementing this number, you can display one "non-trivial" gaps after the other for further examination. For example, you may want to enter 1 to box only a single "non-trivial" gap. Then enter 2 to box the next one, and so forth.

Optionally, enter the total number of "non-trivial" gaps to box all of these gaps at the same time.

7. If the Show Gaps command also indicates "trivial" gaps, you can optionally close these by pressing **CONFIRM**.

Figure 91. Showing Non-Trivial Gaps on page 179 shows an example of a geometry that includes three "non-trivial" gaps.

Figure 91. Showing Non-Trivial Gaps

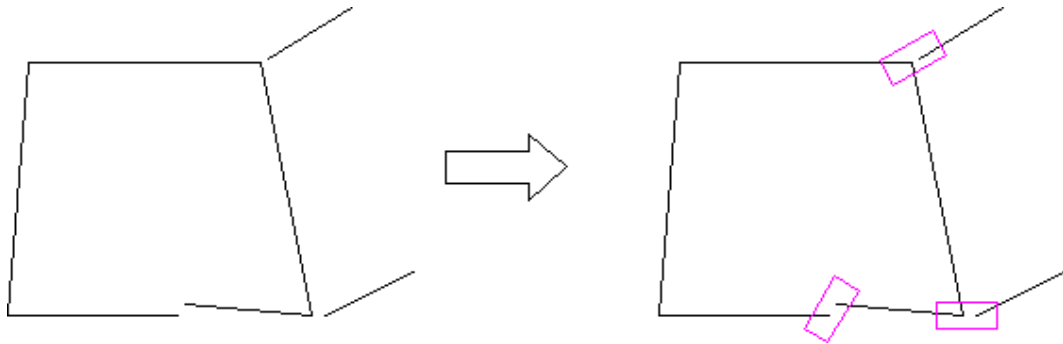

 **Note**

Tip: To clean up most common problems in a part, run the Clean commands in the following sequence:

Points	Merge disconnected points.
Gaps	Close gaps between adjoining elements.
Duplicate	Remove existing duplicates and those caused by merging points.
Stacked	Split overlapping elements.
Duplicate	Remove duplicates caused by splitting.
Staggered	Merge partially overlapping elements.

Further Information

For further technical information about modifying, refer to the Creo Elements/Direct Drafting help system:

Enter `help modify` at the Creo Elements/Direct Drafting command line.

The screen will clear and Creo Elements/Direct Drafting will display further information about modifying your drawing.

8

Dimensioning a Drawing

Dimensioning Fundamentals	181
Dimensioning With Creo Elements/Direct Drafting	186
Preparing to Dimension	192
Single Dimensioning	194
Chain Dimensioning	199
Datum Dimensioning	203
Radius, Diameter, Tangential, and Arc Dimensioning	209
Angle and Chamfer Dimensioning	217
Geometry-Sensing Assignment	221
Database-Matching Assignment	225
Dual Dimensioning	231
Common Interrupt Functions	232
Predefining Prefixes, Postfixes, Superfixes, Subfixes, and Tolerances	236
Selection Filtering	237
Setting and Changing Dimensioning Attributes	243
Setting Line Attributes	243
Setting Text Attributes	254
Changing Line Attributes	269
Setting the Offset Point	274
Setting Dimension Offset	275
Changing Text Attributes	276
Setting Dimension Attributes with the STYLE Table	293
Modifying Dimensions	297
Modifying Dimension and Extension Lines	300
Modifying Chain and Datum Dimensions	304
Modifying a Dimension Vertex	305
Grouping	305
Further Information	305

This chapter shows how to dimension your drawings.

Dimensioning Fundamentals

To clarify how the dimensioning commands work, it is necessary to define the terminology used when discussing dimensioning. Generally, a dimension consists of two parts:

- Dimension Text.
- Dimension Geometry.

What is Dimension Text?

Dimension text describes the geometry feature that is marked by the dimension geometry. Dimension text is divided into the fields:

- Prefix
- Dimension Value
- Tolerance
- Postfix
- Subfix
- Superfix

Figure 92. Dimension Text Examples on page 181 shows several examples of dimension text with the fields indicated.

Figure 92. Dimension Text Examples

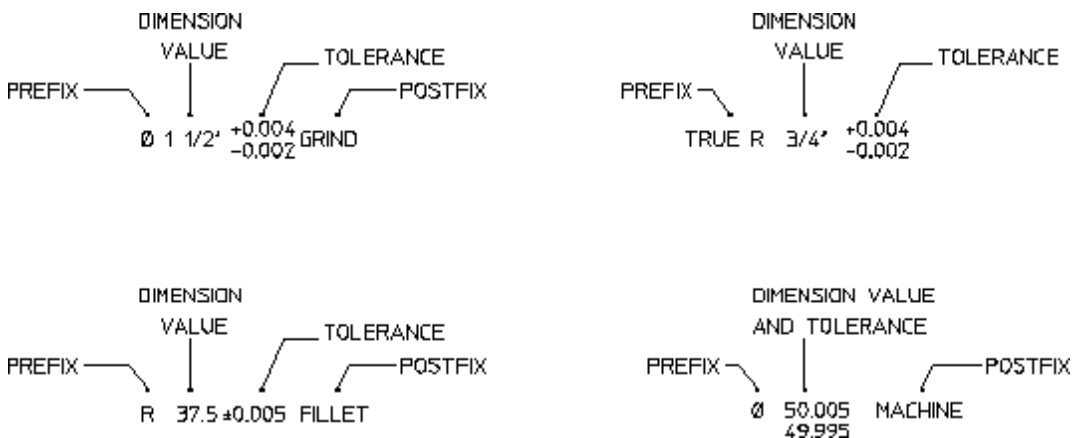

Prefix, tolerance, postfix, subfix and superfix are optional.

What is a Prefix?

Use a prefix to include additional information before the dimension value. Examples of prefixes are: DIA (diameter), TRUE R (true radius), and R (radius).

What is a Dimension Value?

A dimension value is the numerical value assigned to the geometry feature you are dimensioning. The value can be imperial, metric or angular depending on the geometry feature and the standard units you use.

What is a Tolerance?

A tolerance is used to include information about the tolerance allowed in the dimension value. Tolerance is the total amount by which a specific dimension is permitted to vary. Types of tolerances are:

- Limit tolerances
- Plus and minus tolerances
- Upper and lower tolerances

Limit Tolerances

Limit tolerancing is used to give the maximum and the minimum dimension values. The high limit (maximum value) is placed over the low limit (minimum value).

Figure 93. Limit Tolerancing on page 182 shows an example of limit tolerancing.

Figure 93. Limit Tolerancing

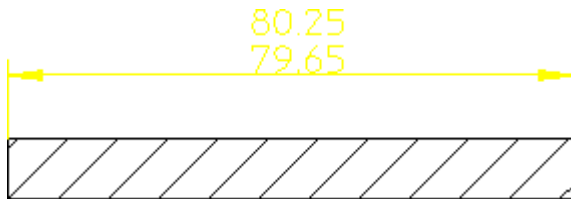

Plus and Minus Tolerances

Plus and minus tolerancing is used to place the tolerance to the right of the dimension value as a plus and minus expression of the tolerance.

Figure 94. Plus and Minus Tolerancing on page 182 shows an example of plus and minus tolerancing.

Figure 94. Plus and Minus Tolerancing

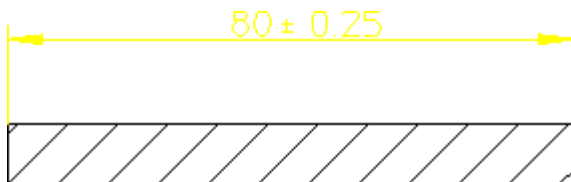

Upper and Lower Tolerances

Upper and lower tolerancing is used to place the tolerances to the right of the specific dimension value. They appear as upper and lower values of the permissible variation of the size of the feature.

Figure 95. Upper and Lower Tolerancing on page 183 shows an example of upper and lower tolerancing.

Figure 95. Upper and Lower Tolerancing

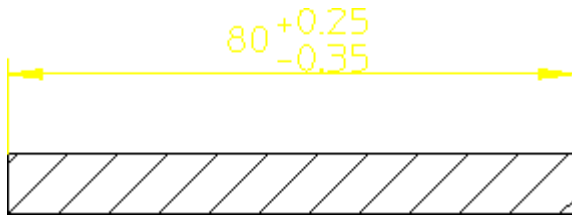

What is a Postfix?

Use a postfix to include additional information after the dimension value. Examples of postfix information are: 3-HOLES EQUALLY SPACED, and CONC (concentric).

What is Dimension Geometry?

Dimension geometry marks the geometry feature corresponding to the dimension text. Dimension geometry consists of:

- Dimension lines
- Extension lines
- A dimension text frame

Figure 96. Dimension Geometry on page 184 shows the three components of dimension geometry.

Figure 96. Dimension Geometry

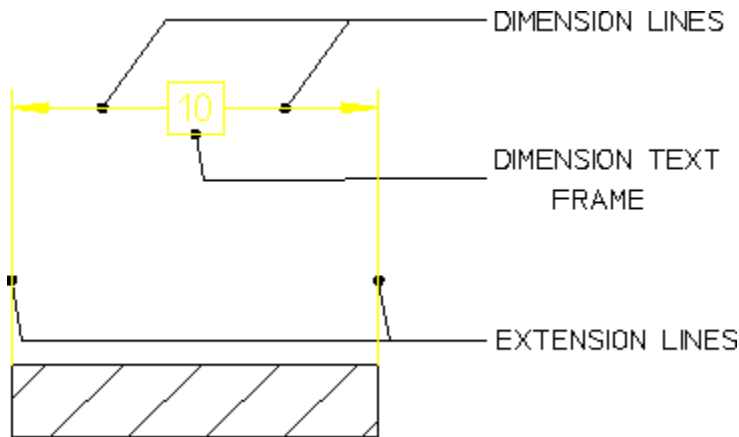

Dimension Lines

Dimension lines show the direction and extent of a dimension. The dimension line may be broken and the dimension text inserted (referred to as on the dimension line), or the line may be a full unbroken line with the dimension text above or below the dimension line. The dimension line will normally end with a terminator.

[Figure 97. Dimension Line Terminators on page 184](#) shows dimension line terminators.

Figure 97. Dimension Line Terminators



Extension Lines

Extension lines show the extension of a surface or point to a location outside the part outline. In most technical drawings, you draw them perpendicular to the dimension line with a visible gap from the geometry feature.

Dimension Text Frames

The dimension text frame surrounds all dimension text relating to the dimension geometry. Normally, the frame is switched off. You can make the frame appear as a box-shaped frame or a balloon-shaped frame or a flag-shaped frame or a basic frame by selecting the appropriate option. . Refer to the [Setting the Dimension Text Format on page 259](#) topic for details.

Setting the Dimension Geometry and Text Distances

As previously described, a dimension is made up of several parts:

- Dimension text
- Dimension lines
- Extension lines

You can set the distance between some of the parts making up a dimension.

Figure 98. [Setting Dimension Distances on page 185](#) shows the most common distances that you can set. Each distance is identified using a letter. Refer to [Table 5. Setting Dimension Distances on page 185](#) for an explanation of the letters.

Figure 98. Setting Dimension Distances

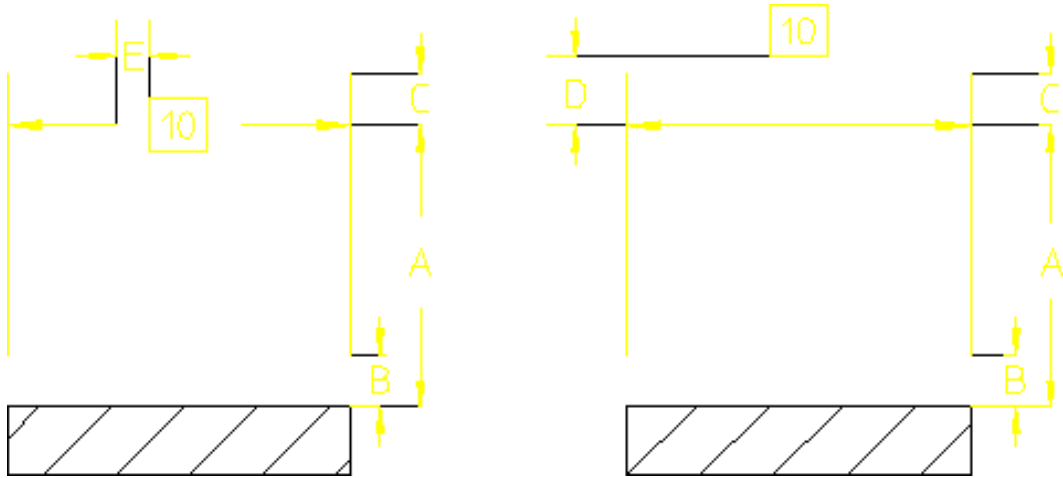

[Table 5. Setting Dimension Distances on page 185](#) gives the distance, the corresponding Creo Elements/Direct Drafting function that sets the distance, and a typical value.

Table 5. Setting Dimension Distances

Dis- tance	Description
A	The minimum distance between the dimension line and the geometry feature. Define with the MIN SPACE function (in SET LINES). The default minimum distance is 0 mm.
B	The distance between the extension line and the geometry feature. Define with the OFFSET PNT function (in SET LINES). The default distance is 0 mm.
C	The distance between the dimension line and the top of the extension line. Define with the OFFSET LIN function (in SET LINES). The default distance is 2 mm.

Table 5. Setting Dimension Distances (continued)

Dis- tance	Description
D	The vertical distance between the dimension line and the dimension text. This only works if the location of the dimension text is above or below the dimension line. Define with the SET OFFSET function (in SET TEXTS). The default distance is 2 mm.
E	The horizontal distance between the dimension line and the dimension text. This only works if the location of the dimension text is on the dimension line. Define with the SET SPACE function (in SET LINES). The default distance is 2 mm.

Dimensioning With Creo Elements/Direct Drafting

The dimensioning module has the following features to make dimensioning your drawing quick and easy:

- A full-featured user interface that includes:
 - An efficient screen menu system.
 - Combination of dimensioning commands and functions.
 - Integration with Creo Elements/Direct Drafting common and selection commands.
- Powerful dimension assignment features:
 - A range of dimensioning assignment methods.
 - Multiple elements can be dimensioned at once.
 - Selection aids speed the assignment process.
 - Dimensioning between parts and on layers.
- Tools for dimension style setting and modification:
 - Standards-based dimensioning styles.
 - Style saving and re-assignment via the STYLE table.
 - Simultaneous modification of dimensioning geometry and text.

The dimensioning module is sometimes referred to as the Dimension Advisor (DA).

Dimensioning Commands and Functions

The dimensioning menus provide both commands and functions. Commands and functions can be combined to perform complex operations in a short amount of time. The current dimension style is indicated in a separate display area in the dimensioning menus.

Dimensioning Commands

Generally, a command remains active until:

- You press **END** to end the command.
- You end the command by starting another command.

This means you can repeat the command without having to press or pick the command again.

For example:

1. Press **DIMENSION 1**.
2. Pick the **SINGLE** command.
3. Identify and dimension more than one geometry feature.
4. When you have finished using **SINGLE**, press **END** to end the command.

Dimensioning Functions

Use functions to interrupt commands. Once you have completed the function, Creo Elements/Direct Drafting will return to the active command.

Combining the Dimensioning Commands and Functions

A powerful feature of the Creo Elements/Direct Drafting dimensioning module is the ability to combine dimensioning commands and functions to perform complex operations efficiently.

The following procedure illustrates the importance of this feature.

Figure 99. Combining Dimensioning Commands and Functions



To create the dimension shown in [Figure 99. Combining Dimensioning Commands and Functions on page 187](#):

-
1. Press **DIMENSION 1**.
 2. Pick **Dialine** in DIAMETER.
 3. Pick Prefix, then enter "DIA".
 4. Pick Postfix, then enter "GRIND".
 5. Pick Upper/Lower in Tolera, then:
 - a. Enter the upper tolerance value, +0.004.
 - b. Enter the lower tolerance value, -0.000.
 6. Identify the circle.
 7. Indicate the desired location for the dimension text.

Remember that DIAMETER and the tolerancing values remain active. This means that you can continue to apply diameter dimensions to other circular geometry features simply by identifying them.

Suppose that you do not want the GRIND postfix to appear in subsequent dimensions. You can remove this postfix without ending the current command by using the CLEAR function:

1. Pick **CLEAR**.
2. Identify another circular element (circle, arc, fillet).
3. Indicate the desired location for the dimension text.

As you can see, combining dimensioning commands and functions reduces the amount of time needed to dimension your drawing.

 **Note**

All the examples in this chapter assume that the current linear units are millimeters and the angular units are degrees. Check the Creo Elements/Direct Drafting System Status Line for the entries mm and deg.

Using the Common and Selection Commands

You can use Creo Elements/Direct Drafting common and selection commands with the dimensioning commands. For more information, refer to [Commonly Used Commands](#) on page 35.

Dimension Assignment Features

Multiple Assignment Methods

The dimensioning module provides several methods for assigning dimensions to drawing elements.

- With direct assignment, you manually select the type of dimension you wish to assign (single, chain, datum, angle, etc.) and then identify one or more drawing elements to receive the selected dimension. For example:
 1. Press **DIMENSION 1** and pick SINGLE.
 2. Identify the dimension points. To dimension a single geometric feature, identify two dimension points to identify the feature. To dimension several drawing elements at the same time, enclose them in a box.
 3. Move the dimension trace around your drawing until the extension lines and dimension text are at the desired location.
 4. Indicate the point to place the dimension text and Creo Elements/Direct Drafting draws the dimension(s).

Direct dimensioning gives you the greatest control over the dimensioning process, but is likely to take the most time.

- Geometry-sensing assignment is provided by the commands `DA_DIM_GEO_SENSE` and `DA_DIM_PD_SCAN`. `DA_DIM_GEO_SENSE` asks you to identify a group of drawing elements and then generates a basic set of dimensions for those elements based on their geometry type and position. `DA_DIM_PD_SCAN` also generates dimensions for a selected set of elements, but it scans the parametric design constraints on the selected elements to determine what type of dimensions to generate.

Geometry-sensing assignment is not intended to provide "automatic" dimensioning, but it does provide a basic dimensioning framework that you can modify to suit your requirements.

To quickly see how geometry-sensing assignment works, try the following:

1. Create a drawing with several different drawing elements.
 2. Enter `DA_DIM_GEO_SENSE ALL` at the command line.

Creo Elements/Direct Drafting creates dimensioning for all elements in the drawing.
 3. To manually adjust the positions of the newly-created dimensions, you can use the `DA_MOVE_DIMENSION` command.
- Database-matching assignment transfers dimensioning from a "dimensioning database" of pre-dimensioned parts to similar drawing elements in your

drawing. Once you create this database, you can use the entries in it as dimensioning templates to quickly generate complete dimensioning for similar parts or features in you drawings.

Database-matching assignment can greatly improve dimensioning speed and accuracy for commonly used drawing details.

Dimensioning Single or Multiple Elements

you can assign dimensions to one or several elements at a time. You assign single dimensions by indicating the individual dimension points you wish to dimension. To assign multiple dimensions, you select whole elements, either with SELECT or by enclosing them in a box.

Selection Aids

Several selection aids are available to help you assign dimensions:

- When dimensioning single elements, you do not have to precisely identify the end points of each element. You can pick two points on the element that are close to each end point and the cursor will catch to the end points automatically.
- When selecting multiple elements for dimensioning, a filter can be applied to the selection process to selectively exclude items from being considered. Geometry can be filtered based on geometry type, linetype, color, orientation, and/or pensize. You set up the filter using the FILTER command on **DIMENSION 2**. The current filter can be enabled or disabled by picking Filter On or Filter Off in **DIMENSION 1**.
- A dimension trace appears after you have identified the dimension points of the geometry features you want to dimension. Creo Elements/Direct Drafting then displays a movable dimension trace which shows:
 - The orientation and location of the dimension(s).
 - The location of the dimension line terminators.
 - The length of extension lines.
 - The dimension text represented by a box.

When multiple elements are selected, the dimensioning trace shows the proposed dimensioning for all the selected elements, allowing you to place the dimensioning text for all of them with a single pick.

Dimensioning Between Parts

To dimension between parts, ensure that the parent part is active. You can then dimension between the parent part and one of its subparts, or between pairs of subparts.

Dimensioning Detail Parts

If you are dimensioning a detail part, you must make it the active part. Otherwise, Creo Elements/Direct Drafting produces incorrect dimensions.

If you attempt to dimension a detail part that is not also the active part, Creo Elements/Direct Drafting will display the following message in the System Prompt Line:

Caution

Detail part is not active. Dimension value reflects the drawing scale.

To make a detail part active:

1. Press **PARTS 1**.
2. Pick **EDIT**.
3. Identify the detail part.

Dimensioning on Layers

Dimensioning on layers is the same as normal dimensioning.

For more information about layers, refer to [Using Layers and Infos on page 449](#).

Style Features

Creo Elements/Direct Drafting provides several methods for setting and changing dimensioning styles. In addition to specific commands that allow you to set and change dimension text attributes (size, font, orientation, spacing, etc.) and line attributes (color, width, spacing, offsets, terminators, etc.), Creo Elements/Direct Drafting also provides tools for emulating dimensioning standards and for storing and recovering often-used styles.

Standards

Dimensioning standards allow you to quickly set Creo Elements/Direct Drafting's dimension style features to emulate popular dimensioning standards, such as ANSI, DIN, JIS, and ISO. A generic "company" standard may also be defined.

Standards are easily selected using the **Standard** command in **DIMENSION 1**. Creo Elements/Direct Drafting displays the current standard adjacent to the **Standard** command.

STYLE Table

The STYLE table allows you to store the current dimensioning style attributes into a table entry. These attributes can later be recovered simply by picking the table entry. Once recovered, these settings become the current dimensioning style and will be used for subsequent dimensions.

Modification Features

Dimension modification features allow you to change the layout of existing dimensioning lines and text. Modification commands are in the MODIFY menu under **DIMENSION 2**.

Preparing to Dimension

Before you assign dimensions to your drawing, you may want to set up the basic dimensioning style that will be used for your dimensions.

You can manually set dimensioning attributes with the SET LINES and SET TEXTS commands on **DIMENSION 3**, which are described later in this chapter. In addition, you can set up dimensioning to emulate a particular standard.

Selecting a Dimensioning Standard

Creo Elements/Direct Drafting can emulate the dimensioning styles specified in various drawing standards as well as allow you to define your own company or site-wide standard. The standards available are:

- ANSI
- DIN
- ISO
- JIS
- Company (Creo Elements/Direct Drafting default)

To select a dimensioning standard:

1. Press **DIMENSION 1**.
2. Pick the field adjacent to Standard to toggle between standards.

Note

To emulate a given dimensioning standard, Creo Elements/Direct Drafting simply executes a macro that calls dimensioning style commands with the appropriate options. If a given dimensioning standard has features that are not supported by Creo Elements/Direct Drafting dimensioning commands, that feature will not be supported.

The dimensioning standards are all defined in the macro file `da_std.mac`. This macro file can be edited by hand in order to set the Company dimensioning style, but the other standards defined in this file should generally not be changed.

Auto-Placement Settings

Several dimensioning commands include an **AUTO** option that causes Creo Elements/Direct Drafting to automatically place dimensions rather than use the dimension trace (**MANUAL** option).

Auto-Placement Position

By default, Creo Elements/Direct Drafting attempts to auto-place dimensions above or to the right of their associated (linear) drawing elements. Using the **POSITION** command, you can ask Creo Elements/Direct Drafting to place dimensions either above and to the right or below and to the left, [Figure 100. Dimensioning Auto-Placement – Above \(a.\) and Below \(b.\) on page 193.](#)

Figure 100. Dimensioning Auto-Placement – Above (a.) and Below (b.)

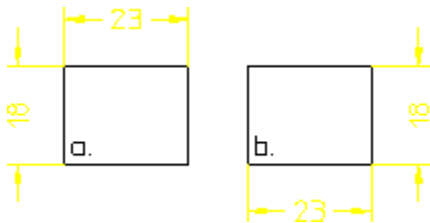

To set the default auto-placement position:

1. Press **DIMENSION 2**.
2. Pick **AUTO PLACE**.
3. Pick **POSITION**.
4. Select **Above** or **Below**.

Intersection Testing

By default, Creo Elements/Direct Drafting attempts to auto-place new dimensions so that the new dimension text does not intersect existing geometry or dimensioning. This process is called intersection testing. Full intersection testing can slow down a busy system, so you are given the option of reducing or disabling intersection testing. Doing this may improve system performance, but will also increase the likelihood that auto-placed dimensions will need to be re-located later. Note that even full intersection testing cannot always prevent overlaps from occurring.

To change the level of intersection testing:

1. Press **DIMENSION 2**.
2. Pick **AUTO PLACE**.
3. Pick **STRATEGY**.
4. Select Off, Geo, or Geo+Dim.
 - Off disables all intersection testing.
 - Geo checks for intersections with geometry elements only.
 - Geo+Dims checks for intersections with geometry elements and with existing dimensioning.

Single Dimensioning

This section shows how to dimension single linear geometry features.

The following options are available to define the orientation of the single dimension relative to a geometry feature:

Parallel	Parallel to a line drawn between two dimension points.
Horizontal	In a horizontal plane.
Vertical	In a vertical plane.
Perpend to	Perpendicular to a reference line on your drawing.
Parall to	Parallel to a reference line on your drawing.

To dimension single linear geometry features:

1. Press **DIMENSION 1**.
2. Pick **SINGLE**.
3. Pick a placement option: **MANUAL** (the default), or **AUTO** (pick option to toggle between **MANUAL** and **AUTO**).
4. Pick an orientation option, the default is **Parallel**.

-
5. Complete the selection sequence required by the option. All options allow you apply dimensioning to a single linear drawing element or to a group of elements depending on your selection. You can:
 - Select any two dimension points. The line between the two points is dimensioned.
 - Select a single linear drawing element. The starting point of the selected element becomes the first dimension point. Select a second dimension point on this or any other linear drawing element to complete the dimension.
 - Select multiple linear drawing elements with SELECT or by enclosing them in a box. The end points of each selected element become dimension points, and each element is dimensioned.
 6. If you selected MANUAL placement, position the dimensions on your drawing. A dimension trace appears when you select elements. Move the trace around your drawing until the dimension text is in the desired location. Pick the desired text location and Creo Elements/Direct Drafting draws the dimension(s). When multiple elements are selected, the trace shows the proposed dimensions for all of them at the same time.

If you selected AUTO placement, Creo Elements/Direct Drafting positions the new dimensions automatically. AUTO placement only applies when you have selected multiple elements for dimensioning.
 7. Press **END** to end this command.

Example

Figure 101. Single Dimensioning – Options on page 196 shows the result of using each single dimensioning option.

Figure 101. Single Dimensioning – Options

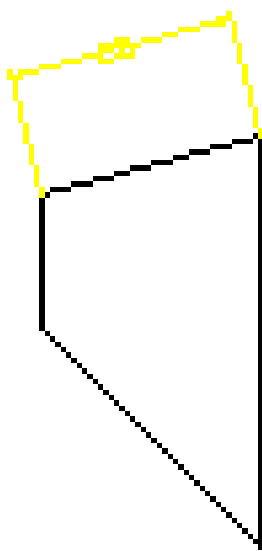

Parallel

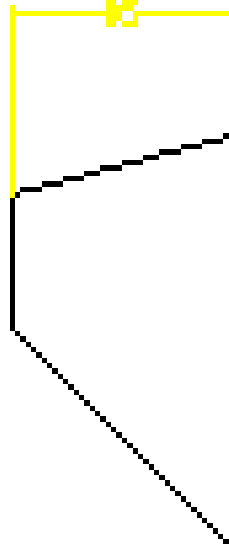

Horizontal

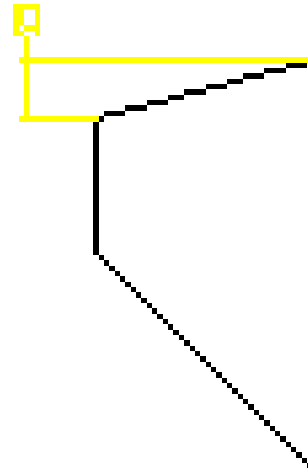

Vertical

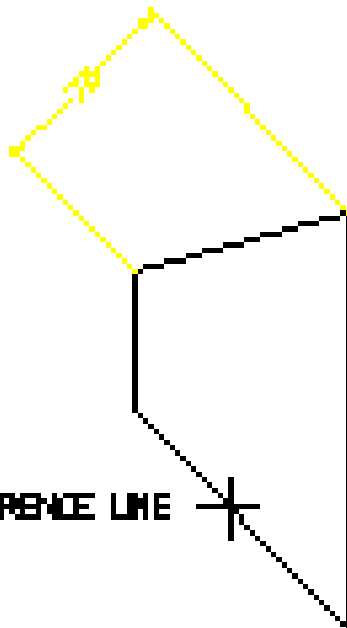

Perpend to

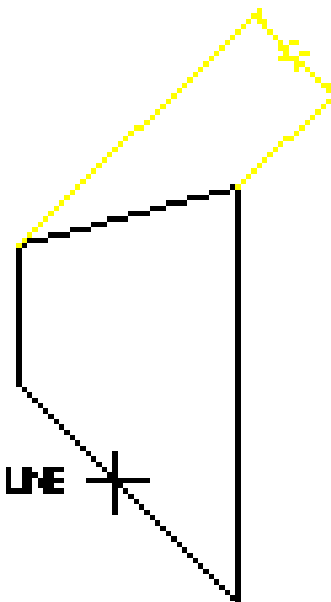

Parallel to

Parallel Dimensions

This is the default option. To dimension along an inclined plane:

1. Press **DIMENSION 1**.
2. Pick **SINGLE** and then **Parallel**.
3. Select **MANUAL** or **AUTO** placement.
4. Select the dimension points or elements to be dimensioned.
5. If **MANUAL** placement was selected, indicate the desired location for the dimension text(s), using the dimension trace for guidance.

Horizontal Dimensions

To produce dimensions in the horizontal plane:

1. Press **DIMENSION 1**.
2. Pick **SINGLE** and then **Horizontal**.
3. Select **MANUAL** or **AUTO** placement.
4. Select the dimension points or elements to be dimensioned.
5. If **MANUAL** placement was selected, indicate the desired location for the dimension text(s), using the dimension trace for guidance.

Vertical Dimensions

To produce dimensions in the vertical plane:

1. Press **DIMENSION 1**.
2. Pick **SINGLE** and then **Vertical**.
3. Select **MANUAL** or **AUTO** placement.
4. Select the dimension points or elements to be dimensioned.
5. If **MANUAL** placement was selected, indicate the desired location for the dimension text(s), using the dimension trace for guidance.

Perpendicular Dimensions

To produce dimensions perpendicular to a reference line:

1. Press **DIMENSION 1**.
2. Pick **SINGLE** and then **Perpend to**.
3. Select **MANUAL** or **AUTO** placement.

4. Identify a reference line. You can identify any line on the drawing as the reference line.
5. Select the dimension points or elements to be dimensioned.
6. If **MANUAL** placement was selected, indicate the desired location for the dimension text(s), using the dimension trace for guidance.

Parallel to a Reference Line

To produce dimensions Parallel to a reference line:

1. Press **DIMENSION 1**.
2. Pick **SINGLE** and then **Parall to**.
3. Select **MANUAL** or **AUTO** placement.
4. Identify a reference line. You can identify any line on the drawing as the reference line.
5. Select the dimension points or elements to be dimensioned.
6. If **MANUAL** placement was selected, indicate the desired location for the dimension text(s), using the dimension trace for guidance.

Symmetry-Style Dimensions

The commands **SYM SINGLE** and **SYM LONG** let you specify symmetry-style dimensions. [Figure 102. Symmetry-Style Dimensioning on page 198](#) shows an example of symmetric dimensioning. In drawing 2, the first dimension point is assumed to be on a symmetry line. No extension line or line terminator is drawn for that element, and the dimension text value is doubled to indicate that the dimension represents both sides of the symmetry line. Drawing 1 shows the unseen half of the geometry.

Figure 102. Symmetry-Style Dimensioning

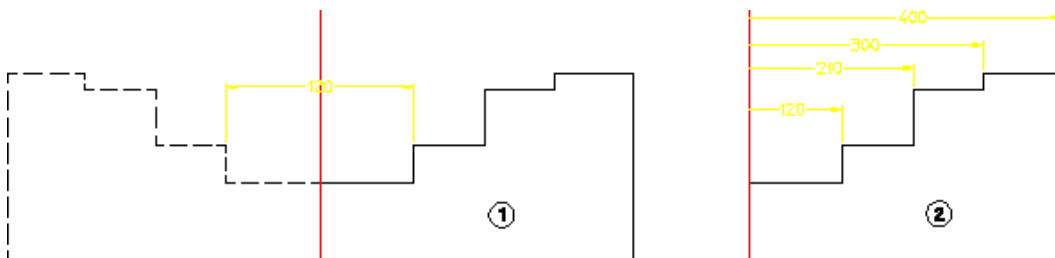

To produce a (single) symmetric dimension:

1. Press **DIMENSION 1**.
2. Pick **SYM SINGLE**.

3. Select the first dimension point.
4. Select the second dimension point.

To produce a (datum) symmetric dimension:

1. Press **DIMENSION 1**.
2. Pick **SYM LONG**.
3. Select the first dimension point.
4. Select the second dimension point.
5. Continue selecting dimension points as required.

Centerline Dimensions

When dimensioning geometry containing centerlines, the dimension extension line is attached to the model point (center point) of the centerline. (Previously, the dimension extension line was attached to the model points of the geometry.) This is true even if the centerlines are not perpendicular to the measured direction of the dimensions.

Figure 103. Dimensions and Centerlines

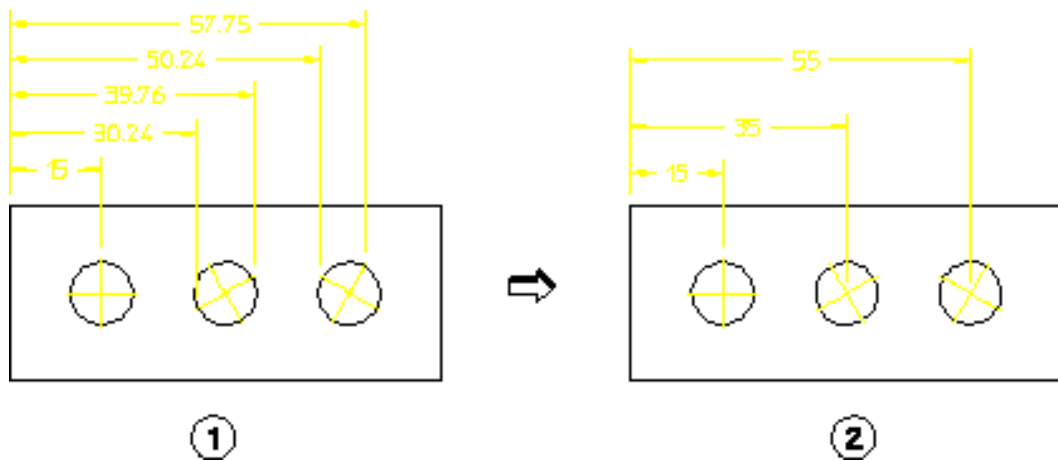

Chain Dimensioning

This section shows how to dimension groups of linear geometry features.

The following options are available to define the orientation of chain dimensions relative to geometry features:

Parallel	Parallel to a line drawn between two dimension points.
Horizontal	In a horizontal plane.
Vertical	In a vertical plane.

Perpend to	Perpendicular to a reference line on your drawing.
Parall to	Parallel to a reference line on your drawing.

Creo Elements/Direct Drafting draws the chain dimensions parallel to the first dimension and chained to the same axis. Locate your first chain dimension so that subsequent chain dimensions do not overwrite the drawing or dimensions. You can correct mistakes by repeatedly pressing **UNDO**, which removes preceding dimensions. You can then indicate the correct points.

To draw chained dimensions:

1. Press **DIMENSION 1**.
2. Pick CHAIN.
3. Select MANUAL or AUTO placement.
4. Pick an orientation option, the default is Parallel.
5. Complete the selection sequence required by the option. All options allow you apply dimensioning to a single linear drawing element or to a group of elements. Depending on your selection, you can:
 - Select any two dimension points. The line between the two points is dimensioned.
 - Select a single linear drawing element. The starting point of the selected element becomes the first dimension point. Select a second dimension point on this or any other linear drawing element to complete the dimension.
 - Select multiple linear drawing elements with SELECT or by enclosing them in a box. The end points of each selected element become dimension points, and each element is dimensioned.
6. If you selected MANUAL placement, position the dimensions on your drawing. A dimension trace appears when you select elements. Move the trace around your drawing until the dimension text is in the desired location. Pick the desired text location and Creo Elements/Direct Drafting draws the dimension(s). When multiple elements are selected, they become the first members of the chain and the trace shows the proposed dimensions for all of them at the same time.

If you selected AUTO placement, Creo Elements/Direct Drafting automatically positions the dimensions. AUTO placement only applies when you have selected multiple elements for dimensioning.
7. To continue chain dimensioning, identify the next point in the dimension sequence.
8. Press **END** to end this command.

Figure 104. Chain Dimensioning on page 201 shows examples of chain dimensioning using each option.

Figure 104. Chain Dimensioning

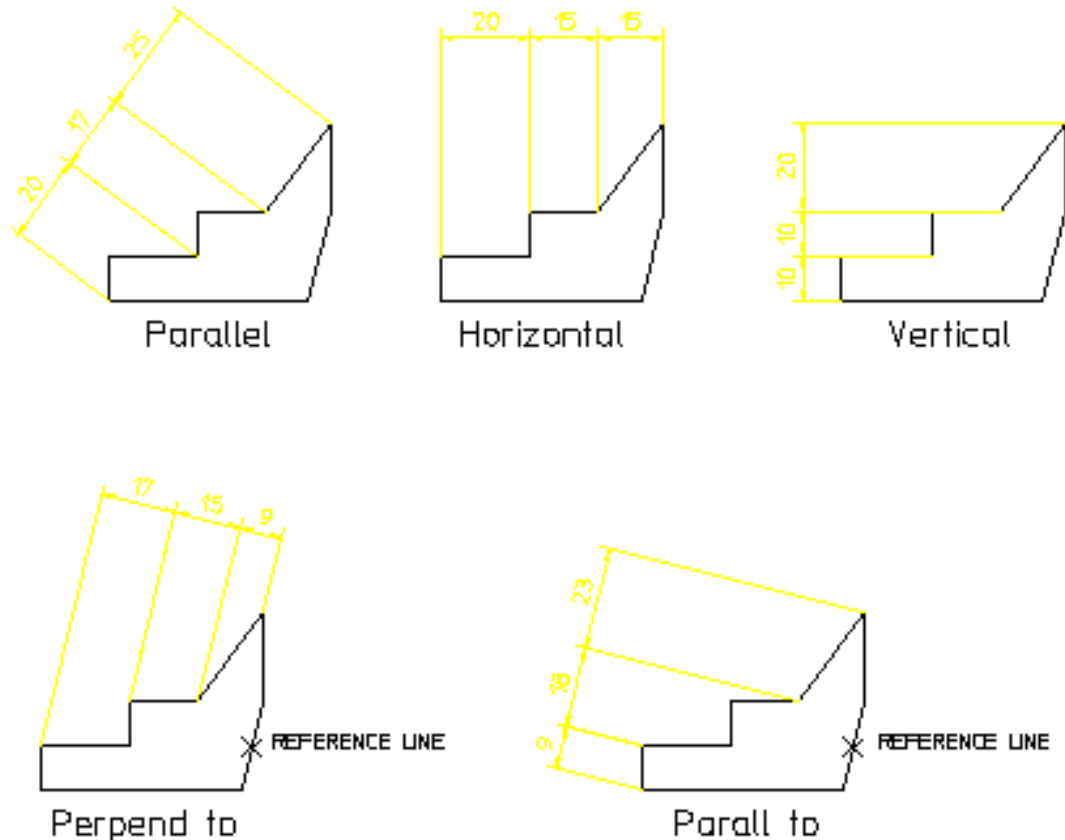

Parallel Dimensions

This is the default option. To chain dimensions along an inclined plane:

1. Press **DIMENSION 1**.
2. Pick **CHAIN** and **Parallel**.
3. Select **MANUAL** or **AUTO** placement.
4. Identify the first two dimension points. These define the angle for this and subsequent chain dimensions.
5. If your initial selection contains multiple drawing elements, you are prompted to identify one of them to provide the reference angle for the chain.
6. If **MANUAL** placement was selected, indicate the desired location for the dimension text(s), using the dimension trace for guidance.

-
7. To continue the chain along the inclined plane, select additional linear elements.

Horizontal Dimensions

To chain dimensions in the horizontal plane:

1. Press **DIMENSION 1**.
2. Pick **CHAIN** and **Horizontal**.
3. Select **MANUAL** or **AUTO** placement.
4. Select the dimension points or elements to be dimensioned. If your selection contains multiple drawing elements, they become the first members in the chain.
5. If **MANUAL** placement was selected, indicate the desired location for the dimension text(s), using the dimension trace for guidance.
6. To continue the chain, select additional linear elements.

Vertical Dimensions

To chain dimensions in the vertical plane:

1. Press **DIMENSION 1**.
2. Pick **CHAIN** and **Vertical**.
3. Select **MANUAL** or **AUTO** placement.
4. Select the dimension points or elements to be dimensioned. If your selection contains multiple drawing elements, they become the first members in the chain.
5. If **MANUAL** placement was selected, indicate the desired location for the dimension text(s), using the dimension trace for guidance.
6. To continue the chain, select additional linear elements.

Perpendicular Dimensions

To create a dimension chain perpendicular to a given line:

1. Press **DIMENSION 1**.
2. Pick **CHAIN** and **Perpend to**.
3. Select **MANUAL** or **AUTO** placement.
4. Identify a reference line. You can identify any line on the drawing as the reference line.

-
5. Select the dimension points or elements to be dimensioned. If your selection contains multiple drawing elements, they become the first members in the chain.
 6. If MANUAL placement was selected, indicate the desired location for the dimension text(s), using the dimension trace for guidance.
 7. To continue the chain, select additional linear elements.

Parallel to a Reference Line

To create a dimension chain parallel to a reference line:

1. Press **DIMENSION 1**.
2. Pick **CHAIN** and **Parall to**.
3. Select MANUAL or AUTO placement.
4. Identify a reference line. You can identify any line on the drawing as the reference line.
5. Select the dimension points or elements to be dimensioned. If your selection contains multiple drawing elements, they become the first members in the chain.
6. If MANUAL placement was selected, indicate the desired location for the dimension text(s), using the dimension trace for guidance.
7. To continue the chain, select additional linear elements.

Datum Dimensioning

This section shows how to create datum dimensions.

Datum dimensioning is useful to mark holes and other features on a part. The dimensions are parallel to each other (like chain dimensioning), and have a common datum point. Normally, design engineers use this type of dimensioning for parts that will be NC machined.

The three datum dimension commands are:

- **DATUM LONG**: creates dimensions using long base lines.
- **DATUM SHRT**: creates dimensions using short base lines.
- **COORDINATE**: creates dimensions without dimension lines. Useful if the geometry of the part will cause the dimension lines to be too close together.

Creating Datum Dimensions

To create a datum dimension:

1. Press **DIMENSION 1**
2. Pick a datum dimension command (DATUM LONG, DATUM SHRT or COORDINATE).
3. Select MANUAL or AUTO placement.
4. Pick an orientation option, the default is Parallel.
5. Complete the selection sequence required by the option. All options allow you apply dimensioning to a single drawing element or to a group of elements.
6. If you selected MANUAL placement, move the dimension trace around your drawing until the dimension text is in the desired location. If multiple drawing elements are selected, the trace shows all proposed dimensions at the same time. Pick the desired text location and Creo Elements/Direct Drafting draws the dimension(s).

If you selected AUTO, all the dimensions are positioned automatically and the trace is not used. AUTO placement only applies when you have selected multiple elements for dimensioning.

7. To continue datum dimensioning, identify the next dimension point.
8. Press **END** to end this command.

The orientation options are:

Parallel	Parallel to a line drawn between two dimension points.
Horizontal	In a horizontal plane.
Vertical	In a vertical plane.
Perpend to	Perpendicular to a reference line on your drawing.
Parall to	Parallel to a reference line on your drawing.

Datum Dimension Examples

Example

Figure 105. Rectangular Plate – Dimensioned with Datum Long on page 205 shows a rectangular plate dimensioned using DATUM LONG and the Parall to orientation option.

Figure 105. Rectangular Plate – Dimensioned with Datum Long

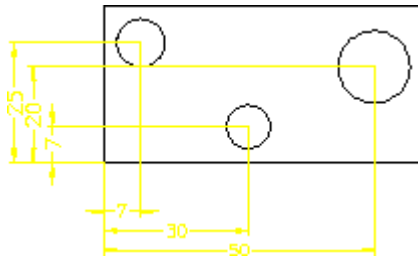

Example

Figure 106. Rectangular Plate – Dimensioned with Datum Short on page 205 shows a rectangular plate dimensioned using DATUM SHRT with Parallel and Vertical orientation options.

Figure 106. Rectangular Plate – Dimensioned with Datum Short

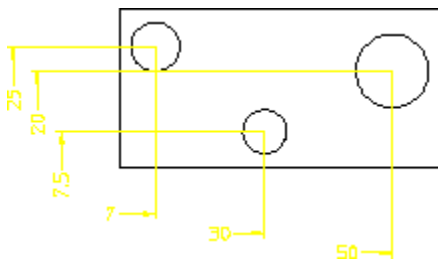

Example

The following example shows how to use COORDINATE to dimension a simple rectangular plate with three holes. Assume that the common datum point is the lower left hand corner of the plate.

Figure 107. Rectangular Plate – Dimensioned with Coordinate on page 206 shows the rectangular plate:

Figure 107. Rectangular Plate – Dimensioned with Coordinate

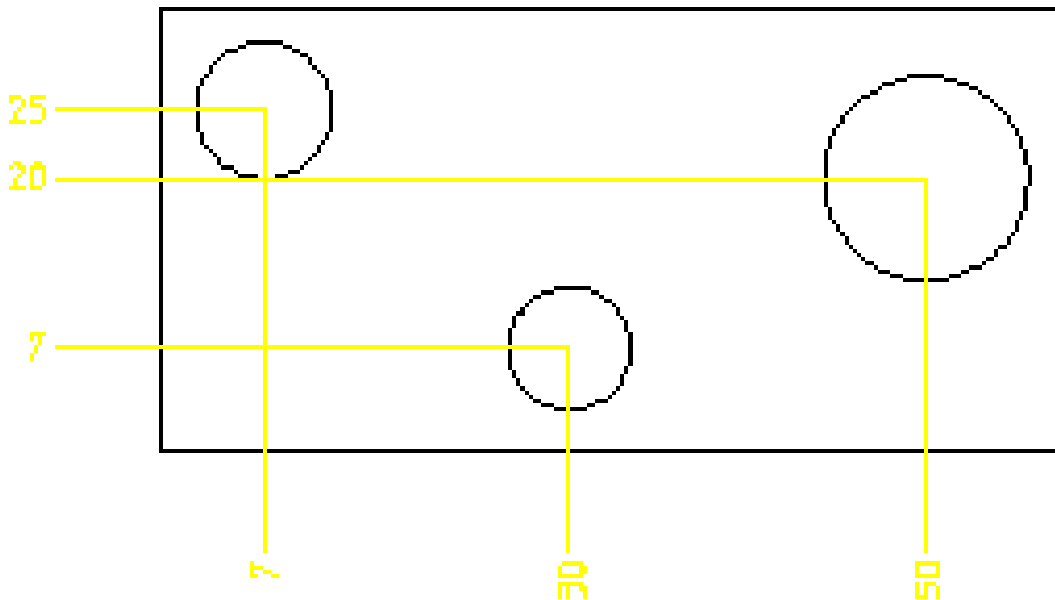

To add the dimensions measured along the vertical (from datum point):

1. Press **DIMENSION 1**.
2. Press **Vertex** in **SHOW**.
3. Pick **COORDINATE**.
4. Pick **Vertical**.
5. Identify the lower left hand corner of the plate.
6. Identify the center of one of the circles.
7. Indicate the position for the dimension text.
8. Repeat step 6 for the other two circles.

To add the dimensions measured along the horizontal (from datum point):

9. Pick **COORDINATE**.
10. Pick **Horizontal**.
11. Identify the lower left hand corner of the plate.
12. Identify the center of one of the circles.
13. Indicate the position for the dimension text.
14. Repeat step 12 for the other two circles.

 **Note**

The dimension text may be preceded by a leading zero. For details see [Setting the Coordinate Dimension Leading Zero on page 268](#) in this chapter.

Parallel Dimensions

This is the default option. To datum dimension along an inclined plane:

1. Press **DIMENSION 1**.
2. Pick a datum dimension command (DATUM LONG, DATUM SHRT or DATUM COOR).
3. Pick **Parallel**.
4. Select MANUAL or AUTO placement.
5. Identify a single dimension point. This becomes the common datum point.
6. Select one or more additional dimensioning points.
7. If MANUAL placement was selected, indicate the desired location for the dimension text(s), using the dimension trace for guidance.
8. To add more dimensions relative to the common datum point, select additional drawing elements.

Horizontal Dimensions

You can dimension in the horizontal plane irrespective of the position of the dimension points.

To dimension in the horizontal plane:

1. Press **DIMENSION 1**.
2. Pick a datum dimension command (DATUM LONG, DATUM SHRT or DATUM COOR).
3. Pick **Horizontal**.
4. Select MANUAL or AUTO placement.
5. Identify a single dimension point. This becomes the common datum point.
6. Select one or more additional dimensioning points.
7. If MANUAL placement was selected, indicate the desired location for the dimension text(s), using the dimension trace for guidance.

-
8. To add more dimensions relative to the common datum point, select additional drawing elements.

Vertical Dimensions

To dimension in the vertical plane:

1. Press **DIMENSION 1**.
2. Pick a datum dimension command (DATUM LONG, DATUM SHRT or DATUM COOR).
3. Pick **Vertical**.
4. Select MANUAL or AUTO placement.
5. Identify a single dimension point. This becomes the common datum point.
6. Select one or more additional dimensioning points.
7. If MANUAL placement was selected, indicate the desired location for the dimension text(s), using the dimension trace for guidance.
8. To add more dimensions relative to the common datum point, select additional drawing elements.

Perpendicular Dimensions

To create a perpendicular datum dimension:

1. Press **DIMENSION 1**.
2. Pick a datum dimension command (DATUM LONG, DATUM SHRT or DATUM COOR).
3. Pick **Perpend to**.
4. Select MANUAL or AUTO placement.
5. Identify a reference line. You can identify any line on the drawing as the reference line.
6. Identify a single dimension point. This becomes the common datum point.
7. Select one or more additional dimensioning points.
8. If MANUAL placement was selected, indicate the desired location for the dimension text(s), using the dimension trace for guidance.
9. To add more dimensions relative to the common datum point, select additional drawing elements.

Parallel to a Reference Line

To create a datum dimension parallel to a reference line:

1. Press **DIMENSION 1**.
2. Pick a datum dimension command (DATUM LONG, DATUM SHRT or DATUM COOR).
3. Pick **Parall to**.
4. Select MANUAL or AUTO placement.
5. Identify a reference line. You can identify any line on the drawing as the reference line.
6. Identify a single dimension point. This becomes the common datum point.
7. Select one or more additional dimensioning points.
8. If MANUAL placement was selected, indicate the desired location for the dimension text(s), using the dimension trace for guidance.
9. To add more dimensions relative to the common datum point, select additional drawing elements.

Radius, Diameter, Tangential, and Arc Dimensioning

Radii Dimensioning

This section shows how to dimension the radius of an arc, circle, BSpline or fillet feature.

When dimensioning an arc, circle, or fillet, the options Centerline and No Centerl are available. These options cause the dimension line to connect to the feature center (Centerline), or not (No Centerl).

Dimension text includes the prefix R (radius).

[Figure 108. Dimensioning Radii on page 210](#) shows an example of a radius dimension with an arc extension with each option, Centerline is shown on the left and No Centerl on the right:

Figure 108. Dimensioning Radii

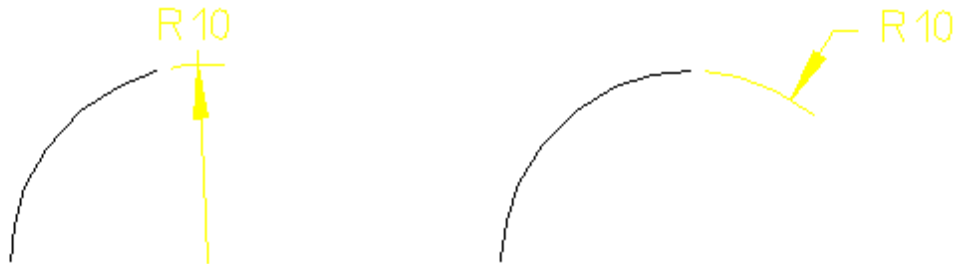

You can locate the dimension text either inside or outside the feature.

To dimension a radius:

1. Press **DIMENSION 1**.
2. Pick **RADIUS** and select a radius option.
3. Select **MANUAL** or **AUTO** placement.
4. Identify one or more arc, circle, or fillet features.
5. If **MANUAL** placement was selected, indicate the desired location for the dimension text(s), using the dimension trace for guidance.
6. Press **END** to end this command.

The **RADIUS** options are:

- Centerline
- No Centerl

Center Line

This is the default option. Pick **RADIUS** and **Centerline** to dimension the radius of a feature with the dimension line drawn from the feature center.

No Center Line

Pick **RADIUS** and **No Centerl** to dimension the radius of a feature with the dimension line drawn towards the center of the feature but not connecting with the center.

 **Note**

To dimension a BSpline, you must select a point on the B-spline. The radius dimension value is valid at the selected point; the dimension value may be different at different points.

Dimensioning a Diameter

This section shows how to dimension the diameter of a:

- Circle
- Arc
- Fillet feature

When dimensioning a diameter, the options Dialine and No Dialine are available. These options cause the dimension line to be drawn across the full diameter (Dialine), or not (No Dialine).

[Figure 109. Dimensioning Circles on page 211](#) shows both command options.

You can locate the dimension text either inside or outside the diameter.

Figure 109. Dimensioning Circles



To dimension a circle, arc or fillet:

1. Press **DIMENSION 1**.
2. Pick **DIAMETER** and a diameter option.
3. Select **MANUAL** or **AUTO** placement.
4. Identify one or more circle, arc, or fillet features.
5. If **MANUAL** placement was selected, indicate the desired location for the dimension text(s), using the dimension trace for guidance.
6. Press **END** to end this command.

The DIAMETER options are:

- Dialine
- No Dialine

With Diameter Line

This is the default option. Pick DIAMETER and Dialine to dimension the diameter of a hole feature with a dimension line drawn fully across the hole diameter.

Without Diameter Line

Pick DIAMETER and No Dialine to dimension the diameter of a hole feature with a dimension line drawn partially across the hole diameter.

Dimensioning using Tangents

Tangential dimensions are useful for dimensioning geometry where vertices are not available. This section shows how to create tangential dimensions on the following elements:

- Circle
- Arc
- Fillet
- Ellipse
- B-spline (closed, both interpolation and control)



Note

Tangential dimensions are not possible for open B-splines.

The following options are available to define the orientation of the tangential dimensions relative to geometry features:

Inclined	In an inclined plane.
Horizontal	In a horizontal plane.
Vertical	In a vertical plane.
Perpend to	Perpendicular to a reference line on your drawing.
Parall to	Parallel to a reference line on your drawing.
Parallel	Parallel to an imaginary line which passes through the selected extreme points on the geometry.

Creo Elements/Direct Drafting always chooses the extreme tangent points of a closed B-spline for dimensioning, for the B-spline with more than two tangent points at the given angle. If you select the points on a closed B-spline and a circle, arc, line, fillet or an ellipse, Creo Elements/Direct Drafting automatically chooses the tangent point of the B-spline which is closest to the selected point on that bspline.

The following figure shows examples of tangential dimensioning on a closed B-spline using each option.

Figure. Tangential Dimensioning

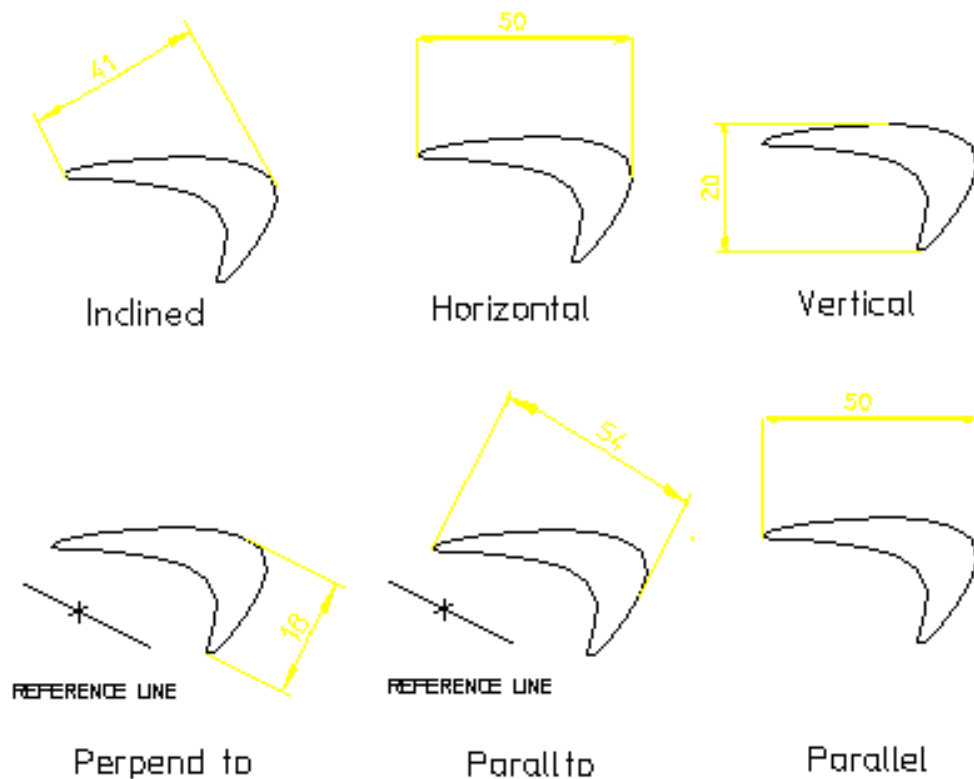

Inclined Dimensions

To create tangential dimensions along an inclined plane:

1. Press **DIMENSION 1**.
2. Pick **TANGENTIAL** and **Inclined**.
3. Select **MANUAL** or **AUTO** placement.
4. Type the inclination angle of the dimension in the User Input Line or move the cursor to define the angle.

-
5. Select the two elements to be dimensioned. The dimension appears at the cursor.
 6. If **MANUAL** placement was selected, indicate the desired location for the dimension text(s), using the dimension trace for guidance.
 7. Press **END** to end this command.

 **Note**

You can specify any value of the inclination angle, Creo Elements/Direct Drafting converts the angle between 360 and -360 degrees.

Horizontal Dimensions

To create tangential dimensions in the horizontal plane:

1. Press **DIMENSION 1**.
2. Pick **TANGENTIAL** and **Horizontal**.
3. Select **MANUAL** or **AUTO** placement.
4. Select the two elements to be dimensioned. The dimension appears at the cursor.
5. If **MANUAL** placement was selected, indicate the desired location for the dimension text(s), using the dimension trace for guidance.
6. Press **END** to end this command.

Vertical Dimensions

To create tangential dimensions in the vertical plane:

1. Press **DIMENSION 1**.
2. Pick **TANGENTIAL** and **Vertical**.
3. Select **MANUAL** or **AUTO** placement.
4. Select the two elements to be dimensioned. The dimension appears at the cursor.
5. If **MANUAL** placement was selected, indicate the desired location for the dimension text(s), using the dimension trace for guidance.
6. Press **END** to end this command.

Perpendicular Dimensions

To create a tangential dimension perpendicular to a reference line:

1. Press **DIMENSION 1**.

-
2. Pick **TANGENTIAL** and **Perpend to**.
 3. Select **MANUAL** or **AUTO** placement.
 4. Identify a reference line. You can identify any line on the drawing as the reference line.
 5. Select the two elements to be dimensioned. The dimension appears at the cursor.
 6. If **MANUAL** placement was selected, indicate the desired location for the dimension text(s), using the dimension trace for guidance.
 7. Press **END** to end this command.

Parallel to a Reference Line

To create a tangential dimension parallel to a reference line:

1. Press **DIMENSION 1**.
2. Pick **TANGENTIAL** and **Parall to**.
3. Select **MANUAL** or **AUTO** placement.
4. Identify a reference line. You can identify any line on the drawing as the reference line.
5. Select the two elements to be dimensioned. The dimension appears at the cursor.
6. If **MANUAL** placement was selected, indicate the desired location for the dimension text(s), using the dimension trace for guidance.
7. Press **END** to end this command.

Parallel Dimensions

To create a tangential dimension that is parallel to a line through the tangent points:

1. Press **DIMENSION 1**.
2. Pick **TANGENTIAL** and **Parallel**.
3. Select **MANUAL** or **AUTO** placement.
4. Select the two elements to be dimensioned. These define the orientation of the dimension. The dimension appears at the cursor.
5. If **MANUAL** placement was selected, indicate the desired location for the dimension text(s), using the dimension trace for guidance.
6. Press **END** to end this command.

Dimensioning Arcs

Creo Elements/Direct Drafting can measure the length or angle of the major or minor arc. When dimensioning arcs singly, you determine which measurement is used by selecting either the start or end point of the arc first. When dimensioning multiple arcs at once, the length or angle of the major arc will be measured. Creo Elements/Direct Drafting measures arcs in a counterclockwise direction.

Dimensioning the length or angle between two arcs is also possible, but only for arcs with the same radius and center.

You can locate the dimension either inside or outside the arc.

To dimension an arc:

1. Press **DIMENSION 1**.
2. Pick **ARC**
3. Pick **Length** or **Angle** to dimension the length or the angle.
4. Select **MANUAL** or **AUTO** placement.
5. Select the arc features to be dimensioned. You can either:
 - Identify the first and second end points on individual arcs. The order in which you select the endpoints determines whether the major or minor arc is dimensioned.
 - Identify one or more arc elements with **SELECT** or by enclosing them in a box. The major arc will be dimensioned for all selected arcs.
6. If **MANUAL** placement was selected, indicate the desired location for the dimension text(s), using the dimension trace for guidance.
7. Press **END** to end this command.

[Figure 110. Dimensioning Arcs — Two Results on page 217](#) shows two possible results of length and angle dimensions obtained using the **ARC** command. Each arc end point is marked in the order in which it has been identified.

Figure 110. Dimensioning Arcs — Two Results

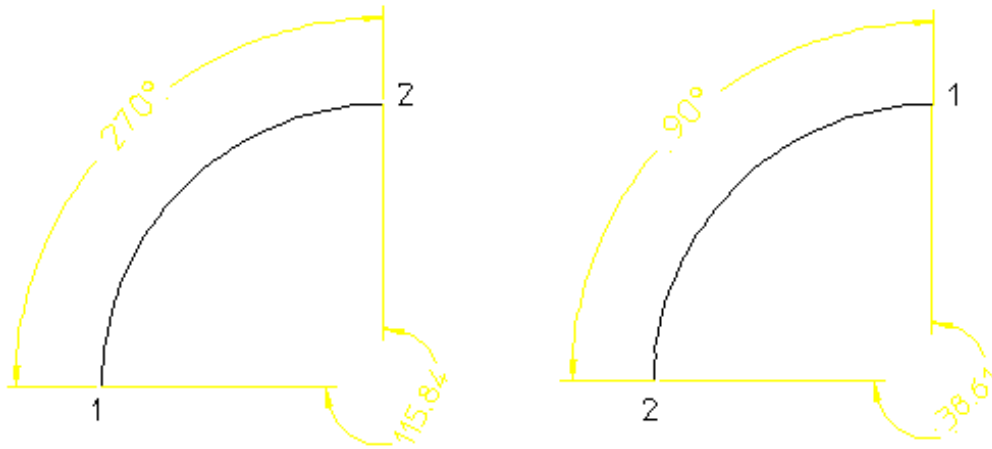

Angle and Chamfer Dimensioning

Dimensioning Angles

During your work you will need to dimension angles between lines. Creo Elements/Direct Drafting measures an angle depending on the order in which you identify the lines making up the angle. Therefore, there are two possible results for each ANGLE option. Creo Elements/Direct Drafting measures angles in a counterclockwise direction.

To dimension an angle:

1. Press **DIMENSION 1**.
2. Pick **ANGLE** and the desired angle option.
3. Select **MANUAL** or **AUTO** placement.
4. Identify the two lines that make up the angle.
5. If **MANUAL** placement was selected, indicate the desired location for the dimension text(s), using the dimension trace for guidance.
6. Press **END** to end this command.

The **ANGLE** options are:

- Direct
- Opposite
- Adjacent -
- Adjacent +

For each of the above options you can achieve two results.

Figure 111. [Identifying Angle Lines on page 218](#) shows how you identify the angle lines in the opposite order to achieve a different result.

Figure 111. Identifying Angle Lines

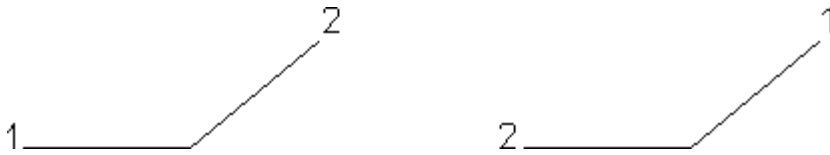

Between Two Lines

Figure 112. [Angle Between Two Lines — Two Results on page 218](#) shows the two possible results.

Figure 112. Angle Between Two Lines — Two Results

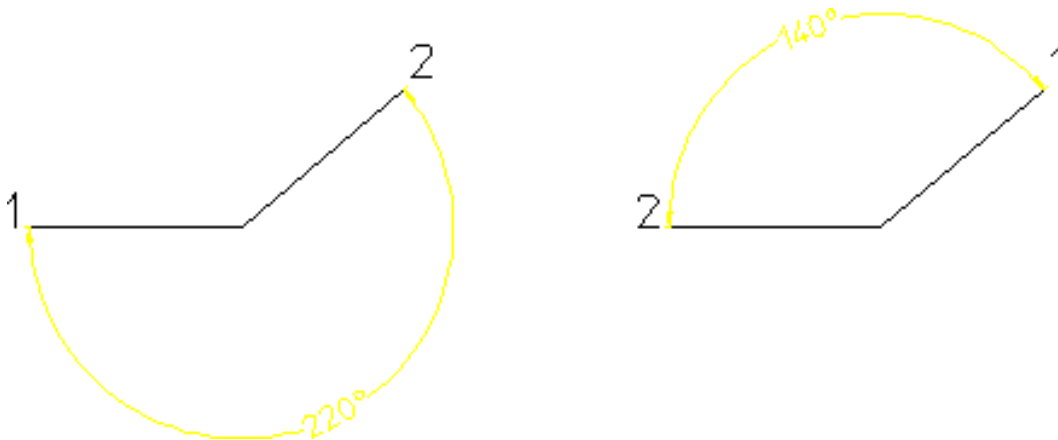

To dimension the angle between two lines:

1. Pick **ANGLE** and the Direct option.
2. Select **MANUAL** or **AUTO** placement.
3. Identify the two lines making up the angle (the angle dimensioned depends upon which of the two lines you identify first).
4. If **MANUAL** placement was selected, indicate the desired location for the dimension text(s), using the dimension trace for guidance.

Between Intersections

Figure 113. [Angle Between Intersections – Two Results on page 219](#) shows the two possible results.

Figure 113. Angle Between Intersections – Two Results

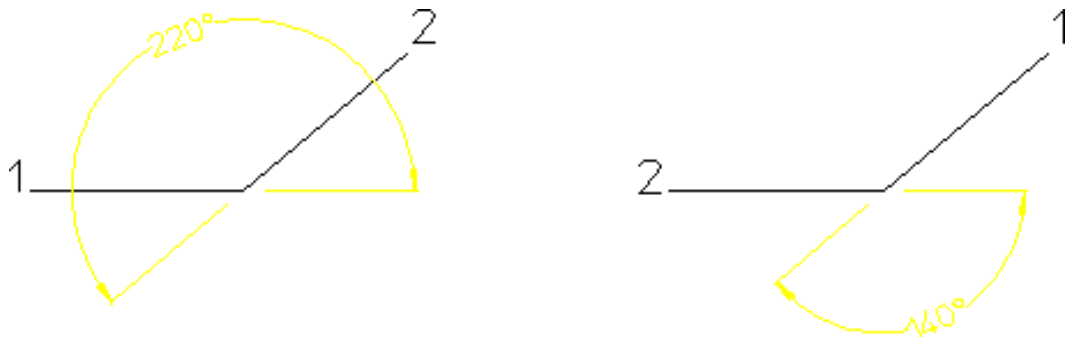

To dimension the angle between the projected intersection of two lines:

1. Pick ANGLE and the Opposite option.
2. Select MANUAL or AUTO placement.
3. Identify the two lines making up the angle (the angle dimensioned will depend upon which of the two lines you identify first).
4. If MANUAL placement was selected, indicate the desired location for the dimension text(s), using the dimension trace for guidance.

Between First and Second Line

Figure 114. Angle Between First and Second Line – Two Results on page 219 shows the two possible results.

Figure 114. Angle Between First and Second Line – Two Results

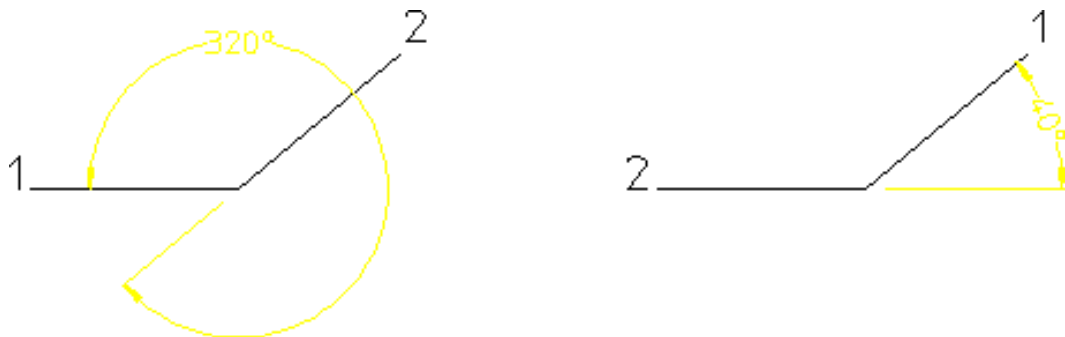

To dimension the angle between the first line you picked and the projection of the second line:

1. Pick ANGLE and the Adjacent - option.
2. Select MANUAL or AUTO placement.
3. Identify the two lines making up the angle (the angle dimensioned depends upon which of the two lines you identify first).

- If MANUAL placement was selected, indicate the desired location for the dimension text(s), using the dimension trace for guidance.

Between Second and First Line

Figure 115. Angle Between Second and First Line – Two Results on page 220 shows the two possible results.

Figure 115. Angle Between Second and First Line – Two Results

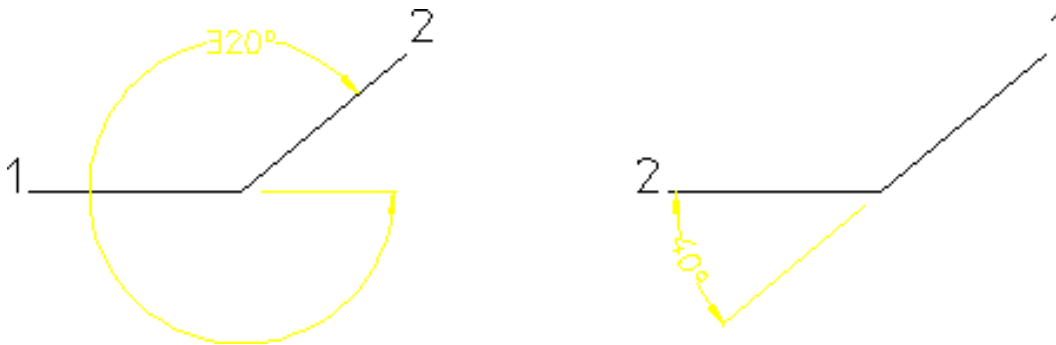

To dimension the angle between the second line you picked and the projection of the first line:

- Pick ANGLE and the Adjacent + option.
- Select MANUAL or AUTO placement.
- Identify the two lines making up the angle (the angle dimensioned depends upon which of the two lines you identify first).
- If MANUAL placement was selected, indicate the desired location for the dimension text(s), using the dimension trace for guidance.

Dimensioning a Chamfer

Chamfered surfaces can be dimensioned using the CHAMFER command in the **DIMENSION 1** menu. (This feature is required in certain countries to meet recognized design standards.)

By default the chamfer dimension is preceded by the character C. Only chamfered surfaces created with the chamfer option Vertex or set at an angle of 45° can be dimensioned.

Figure 116. Dimensioning a Chamfer

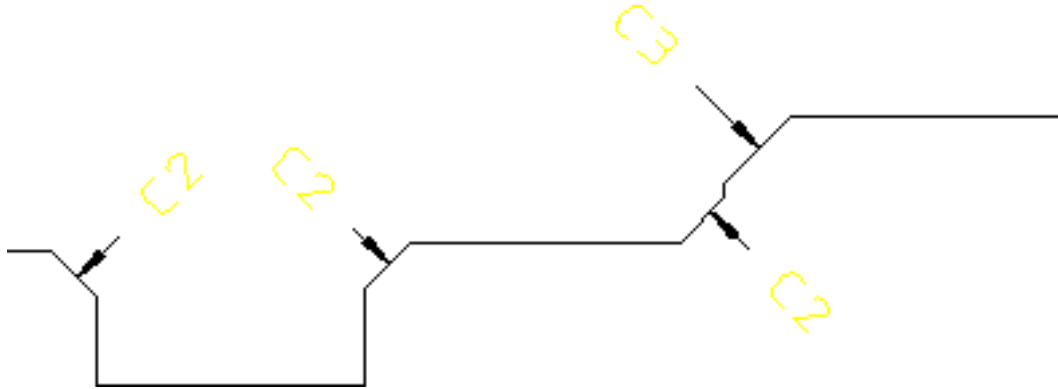

To dimension a chamfer:

1. Press **DIMENSION 1**.
2. Pick **CHAMFER**.
3. Select **MANUAL** or **AUTO** placement.
4. Identify one or more vertices.
5. If **MANUAL** placement was selected, indicate the desired location for the dimension text(s), using the dimension trace for guidance.
6. Press **END** to end this command.

 **Note**

Use `DIM_CHAMFER_TEXT_CONTROL` and `DIM_CHAMFER_PREFIX_STRING` to change the default chamfer prefix string.

If you stretch a chamfer or its reference geometry, the chamfer reference geometry is updated. However, the chamfer dimensions are not updated. The chamfer dimensions may not be visible after you stretch the chamfer.

Geometry-Sensing Assignment

The `GEO SENSE` and `SCAN` commands on the **DIMENSION 1** menu quickly generate basic dimensioning for a selected set of drawing elements based on their geometry types, positions, and parametric constraints, if any.

Geometry-sensing assignment is not intended to provide "automatic" dimensioning. It is best used to provide a basic dimensioning framework that you can then modify as needed to generate the final dimensioning.

Dimensioning with GEO SENS

GEO SENS assigns dimensions to a selected group of geometric elements. The type and location of the dimensions is determined automatically by the system, based on the geometry type and the location of the selected elements. The following dimension types can be generated:

DIM_LINE	for lines
DIM_RADIUS	for arcs, fillets and circles (by default)
DIM_DIAMETER	for arcs, fillets and circles (optional)
DIM_CHAMFER	for 45-degree chamfers (optional)
DIM_ARC	for arcs and fillets (optional)

To assign dimensions with GEO SENS:

1. Press **DIMENSION 1**.
2. Pick GEO SENS and any needed option.
3. Identify a group of drawing elements, either with SELECT or by boxing them.
Creo Elements/Direct Drafting generates and positions dimensions for the selected elements.
4. Press **END** to end this command.

The GEO SENS options are:

- Diameter
- Radius
- Chamfer
- No Chamfer
- Arcs
- No Arcs

Figure 117. GEO SENS options on page 223 shows the effects of these options on the resulting dimensions.

Figure 117. GEO SENS options

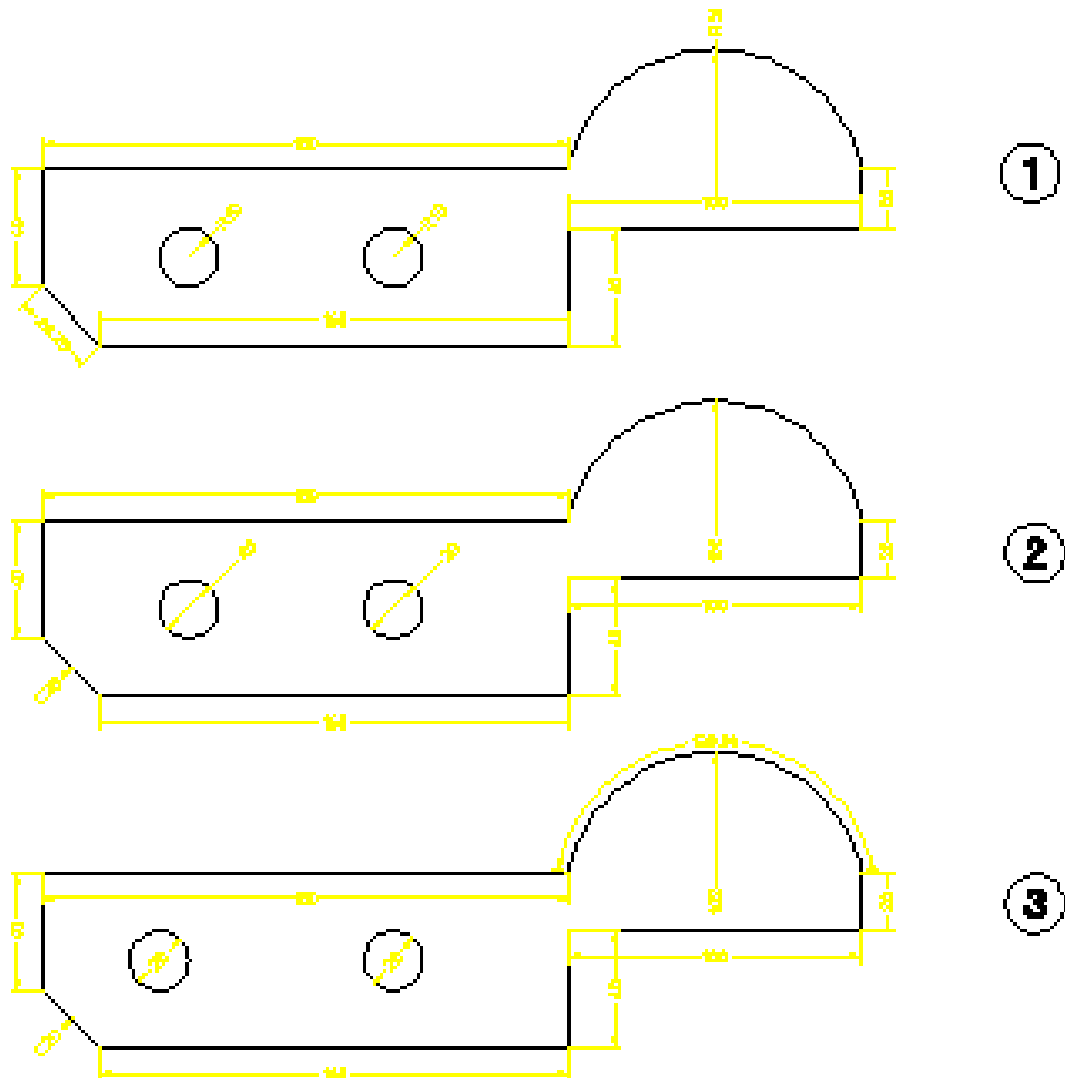

- 1 Defaults
- 2 Diameter and Chamfer On
- 3 Diameter, Chamfer, and Arc On

Diameter

Pick GEO SENS and then Diameter to force all circular elements in the selection set to be given diameter dimensioning.

Radius

Pick GEO SENS and then Radius to force all circular elements in the selection set to be given radius dimensioning. This is the default option.

Chamfer

Pick **GEO SENS** and then **Chamfer** to force chamfer dimensions to be generated for any valid chamfers found in the selection set.

No Chamfer

Pick **GEO SENS** and then **No Chamfer** to prevent chamfer dimensions from being generated for elements in the selection set that qualify as valid chamfers. This is the default option.

Arcs

Pick **GEO SENS** and then **Arcs** to force arc dimensions to be generated for any arc elements, including fillets, found in the selection set.

No Arcs

Pick **GEO SENS** and then **No Arcs** to prevent arc dimensions from being generated for arc elements, such as fillets, found in the selection set. This is the default option.

Dimensioning with SCAN

SCAN assigns dimensions to a selected group of geometric elements. The type and location of the dimensions are determined from parametric constraints currently assigned to the selected elements. Generally, the constraint information allows **Creo Elements/Direct Drafting** to generate more accurate dimensioning than is possible with **GEO SENS**. If no constraints are present in the selected geometry, however, dimensions will not be generated.

SCAN generates the following dimension types for selected elements:

DIM_LINE	for lines and splines
DIM_ANGLE	for angle elements
DIM_RADIUS	for arcs, fillets and circles (by default)
DIM_DIAMETER	for arcs, fillets and circles (optional)

To assign dimensions with **SCAN**:

1. Press **DIMENSION 1**.
2. Pick **SCAN** and any needed option.
3. Identify a group of drawing elements, which must have been previously given parametric constraints, either with **SELECT** or by boxing them.

Creo Elements/Direct Drafting generates dimensions for the selected elements.

4. Press **END** to end this command.

The SCAN options are:

- Diameter
- Radius

Diameter

Pick SCAN and then Diameter to force all circular elements in the selection set to be given diameter dimensioning.

Radius

Pick SCAN and then Radius to force all circular elements in the selection set to be given radius dimensioning. This is the default option.

Database-Matching Assignment

Database-matching commands allow you to create a database of common drawings, parts, or features that have already been dimensioned to company standards. You can then use the entries in this database as templates for assigning dimensions to similar (but not necessarily identical) features and parts in the future, ensuring consistent dimensioning.

All database-matching commands are found on **DIMENSION 2** in the DB MATCH menu.

Database Matching Example

1. Draw and dimension the flange shown in [Figure 118. Initial Part for Database Matching on page 226.](#)

Figure 118. Initial Part for Database Matching

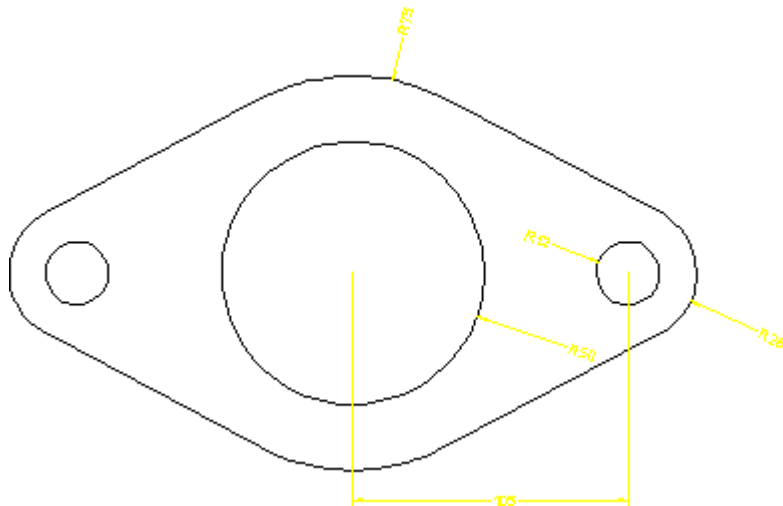

2. Add the flange to the dimension database:
 - a. Delete the construction lines from the drawing.
 - b. Press **DIMENSION 2** and pick DB MATCH.
 - c. Pick ADD
 - d. Enter the name 'Flange 001' when prompted.
 - e. Select the entire drawing by boxing it.

Creo Elements/Direct Drafting adds your drawing to the dimension database.
3. Delete all dimensions from your drawing, and using MODIFY, make two or three copies of it. You can further modify each copy by scaling the whole part or resizing the holes, [Figure 119. New Parts Needing Dimensions on page 227](#). Do not make modifications that alter the basic topology of the part.

Figure 119. New Parts Needing Dimensions

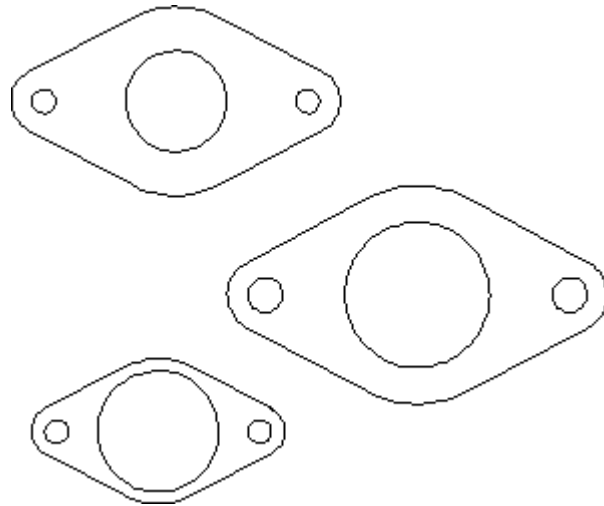

4. Return to **DIMENSION 2** and pick the 'Flange 001' entry from the database table.

Creo Elements/Direct Drafting shows the 'Flange 001' entry in the style display window.

5. Identify a reference element on the 'Flange 001' entry by picking directly in the style display window. For this example, start by picking the line element on the lower left edge of the flange.
6. Identify the corresponding target element on one of the flanges in your drawing.

Creo Elements/Direct Drafting transfers the dimensioning from the database entry to the target drawing, [Figure 120. Assigning Dimensions from the Database on page 228](#). You may need to repeat the previous two steps in order to transfer the dimensioning for the flange holes.

Note that each time you transfer dimensions from the database to the target, a portion of the database entry is highlighted. Once a database element is highlighted, it cannot be used for further matching during this iteration of the command. You can start a new iteration of the command by re-picking the name of the entry from the database table.

7. Repeat the previous three steps as needed until all the flanges in your drawing are dimensioned.

Figure 120. Assigning Dimensions from the Database

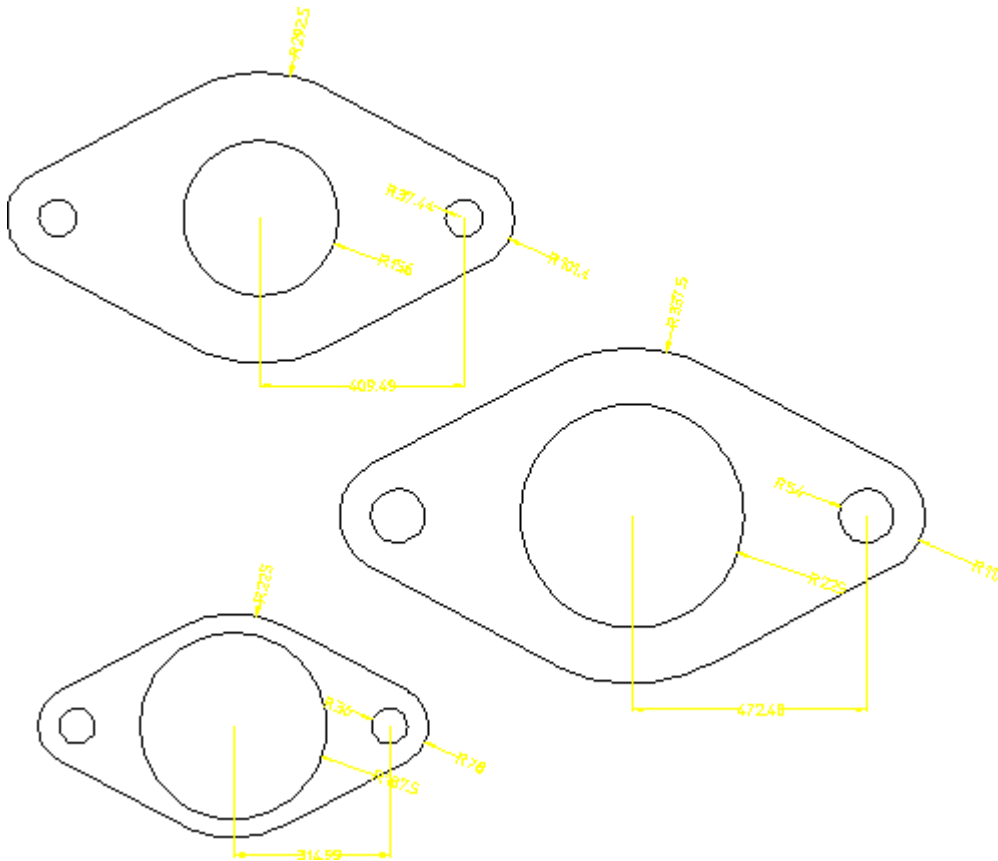

Adding Entries to the Dimension Database

1. Press **DIMENSION 2** and pick DB MATCH.
2. Pick **ADD**
3. Enter the name that will identify this entry ("flange 002", for example).
4. Select the geometry to be added to the database by boxing.

Creo Elements/Direct Drafting creates a new entry in the database and adds the selected geometry under that entry.

Deleting Entries from the Dimension Database

1. Press **DIMENSION 2** and pick DB MATCH.
2. Pick **DELETE**
3. Enter the name of the entry to be deleted, either by picking its entry in the dimension database table or by typing it on the command line.

Creo Elements/Direct Drafting deletes the selected entry from the dimension database.

Assigning Dimensions from the Database

1. Press **DIMENSION 2** and pick **DB MATCH**.
2. Select a database entry by picking its entry in the database table.
Creo Elements/Direct Drafting draws the database entry in the style display window.
3. Pick one end of a reference element on the database entry. Do this by picking directly in the style display window.
4. Pick the corresponding end of a target element in your drawing.
Creo Elements/Direct Drafting dimensions your drawing to match the database entry.
5. Press **END** to end this command.

Note

If you find that a template image in the style display window is too small or not detailed enough for you to easily select a reference element, you can use **WINDOW** or **SHOW** commands in this window to make your job easier. To make the style display window active so that these commands will work on it, pick on the – mark at the top right corner of the window.

Working Methods and Limitations

When assigning dimensions from the database, you should follow the guidelines below for the best results.

- The topology of the database entry and your drawing must be the same. You cannot, for example, use a circular template to assign dimensions to a rectangle. The assignment tool can compensate for minor topological differences such as line splits, but major differences will lead to unsatisfactory results.

The topological differences between a database entry and your drawing may be subtle. If dimension assignments don't appear to be working correctly, you can use commands like **SHOW VERTEX ON** in both your drawing window and the style display window to try to track down the differences.

-
- The part structure (if any) of the database entry and your drawing should be similar. Results can be unsatisfactory if you try to match a multi-part database entry to a single-part drawing.
 - The reference element on the database entry and the target element on your drawing must be in the same relative location, or the resulting dimensioning will be unpredictable.
 - A reference element can only be matched once in a single iteration of the DA_DB_MATCH command. Once you have matched one or more reference elements to your drawing, they are highlighted in the style display to indicate that they cannot be used for further matching.

Exporting a Database Entry

The EXPORT option copies a selected entry from the dimensioning database into the current drawing. The copied entry becomes a new part in the current drawing.

A common application for EXPORT is to edit an entry in the dimensioning database. To edit a database entry, export it into the current drawing, edit the exported geometry, then ADD it back into the database.

Saving and Loading Dimension Databases

You can use the STORE and LOAD commands to save the current dimension database to a file and later reload it into Creo Elements/Direct Drafting. Note that when you load a database into Creo Elements/Direct Drafting, its entries are appended to the current database.

To save the current database:

1. Pick **DB MATCH** from the **DIMENSION 2** menu.
2. Pick **STORE**.
3. Enter a filename ("Flange_DB", for example).

Creo Elements/Direct Drafting will store the current database under the given filename.

To load a dimension database from a file, appending to the current database:

1. Pick **DB MATCH** from the **DIMENSION 2** menu.
2. Pick **LOAD**.
3. Enter a filename ("Flange2_DB", for example).

Creo Elements/Direct Drafting will load the entries from the named database file at the end of the current database.

Unloading the Dimension Database From Memory

To unload the current dimension database from memory and clear the current database table, use the UNLOAD command:

1. Pick **DB MATCH** from the **DIMENSION 2** menu.
2. Pick **UNLOAD**.

Creo Elements/Direct Drafting unloads the current database from memory.

Dual Dimensioning

Optionally, two different units of measure can be used in the same dimension. One of these serves as the primary dimension unit and the other as the secondary dimension unit. To avoid confusion, it is a good idea to enclose the secondary dimension in brackets.

The following example shows you how to set the secondary unit to inches. The example assumes that the primary unit is set to mm.

1. In the **SETUP 1** menu, pick **Dimensions**.
2. In **DIMENSIONS ENV**, set `CURRENT_DIM_TEXTS_SEC_ALL_BRACKETS` to ON.
3. In **DIMENSIONS ENV**, set `Current_secondary_dim_linear_unit` to Inches.

[Figure 121. Dual Dimensioning on page 231](#) illustrates the result. Note that the secondary dimension text (in inches) is displayed in brackets.

Figure 121. Dual Dimensioning

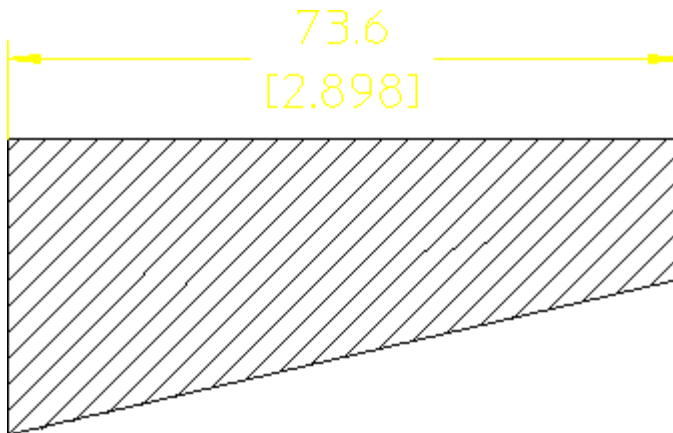

Common Interrupt Functions

You can interrupt any direct assignment command to change the prefix, postfix, and/or tolerance values for the dimension text. To find out how to predefine these values, see [Predefining Prefixes, Postfixes, Superfixes, Subfixes, and Tolerances on page 236](#) in this chapter.

Adding a New Prefix

You can interrupt a dimensioning command to add a new prefix to the dimension text. Examples of prefixes are:

- DIA (diameter)
- R (radius)
- CHAMFER
- BC (base circle)

After entering the prefix, complete the dimensioning command and Creo Elements/Direct Drafting will draw the dimension including the prefix.

The new prefix will also be included in all subsequently assigned dimensions. This avoids having to enter the same prefix every time you are dimensioning a similar geometry feature.

To add a new prefix:

1. Press **DIMENSION 1** and pick Prefix.
2. Enter the prefix text (in quotes ' ' or " ").
3. Complete the dimensioning command.

Creo Elements/Direct Drafting draws the dimension including the prefix text.

To cancel the function and leave the dimensioning command active, press CLEAR.

Defining Softkeys

You can customize the keyboard so that you can include special characters such as the symbol for degree ° and the Greek character "phi" in your prefix:

1. Define the softkey [f1] to degree symbol °:
Enter `DEFINE_KEY 1 (CHR 179)` and press [Enter].
2. Define the softkey [f2] to "phi":
Enter `DEFINE_KEY 2 (CHR 210)` and press [Enter].

Now whenever you press the appropriate softkey you can include the required symbol in your prefix.

Clearing the Current Prefix

You can interrupt a dimensioning command to clear the currently active prefix. Subsequently assigned dimensions will not have a prefix.

To clear the current prefix:

1. Press **DIMENSION 1** and pick CLEAR.
2. Complete the dimension command.

Creo Elements/Direct Drafting draws the dimension without a prefix.

To cancel the function and leave the dimensioning command active, press CLEAR.

Adding a New Postfix

You can interrupt a dimensioning command to enter new postfix text.

Examples of postfixes are:

- 3-HOLES EQUALLY SPACED
- CONC (concentric)

After entering your postfix, complete the dimensioning command and Creo Elements/Direct Drafting will draw the dimension including the postfix.

The new postfix will also be included in all subsequently assigned dimensions. This avoids having to enter the same postfix every time you are dimensioning a similar geometry feature.

To add a new postfix:

1. Press **DIMENSION 1** and pick Postfix.
2. Enter your postfix text (in quotes ' ' or " ").
3. Complete the dimensioning command.

Creo Elements/Direct Drafting draws the dimension including your postfix text.

To cancel the function and leave the dimensioning command active, press CLEAR.

Clearing the Current Postfix

You can interrupt a dimensioning command to clear the currently active postfix. Subsequently assigned dimensions will not have a postfix.

To clear the current postfix:

1. Press **DIMENSION 1** and pick Postfix.

-
2. Pick **CLEAR**.
 3. Complete the dimension command.

Creo Elements/Direct Drafting draws the dimension without a postfix.

To cancel the function and leave the dimensioning command active, press **CLEAR**.

Adding a New Tolerance

You can interrupt a dimensioning command to add a new tolerance to a dimension. After entering your tolerance, complete the dimensioning command and Creo Elements/Direct Drafting will draw the dimension including the tolerance.

The new tolerance will also be included in all subsequently assigned dimensions. This avoids having to enter the same tolerance every time you are dimensioning a similar geometry feature.

To add a new tolerance:

1. Press **DIMENSION 1** and pick an option in Tolera.

Creo Elements/Direct Drafting prompts for the necessary tolerance information.

2. Enter the tolerance information.
3. Complete the dimensioning command.

Creo Elements/Direct Drafting draws the dimension including the tolerance.

To cancel the function and leave the dimensioning command active, press **CLEAR**.

The Tolera options are:

- Plus/Minus
- Upper/Lower
- Limit

Plus/Minus Tolerance

This is the default option. The tolerance can either be a value, or a string of up to 24 characters. The string must be in quotes ' ' or " ".

[Figure 122. Plus and Minus Tolerancing on page 235](#) shows an example of plus and minus tolerancing.

Figure 122. Plus and Minus Tolerancing

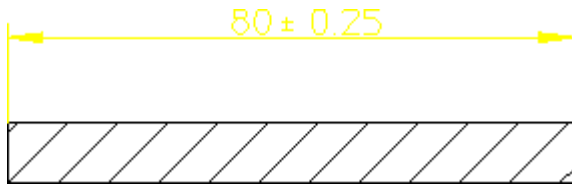

To add a plus/minus tolerance:

1. Press **DIMENSION 1**.
2. Pick Plus/Minus in Tolera.
3. Enter the plus and minus tolerance value, or string.

Upper and Lower Tolerancing

The tolerance can either be a value, or a string of up to 24 characters. The string must be in quotes ' ' or " ". Creo Elements/Direct Drafting assumes that both upper and lower values are positive.

If you require either value to be negative, you must start the tolerance with a negative sign (-).

[Figure 123. Upper and Lower Tolerancing on page 235](#) shows an example of upper and lower tolerancing.

Figure 123. Upper and Lower Tolerancing

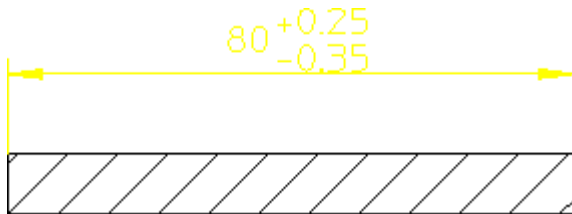

To add an upper and lower tolerance:

1. Press **DIMENSION 1**.
2. Pick **Upper/Lower** in Tolera.
3. Enter the upper tolerance value, or string.
4. Enter the lower tolerance value, or string.

Limit Tolerancing

Creo Elements/Direct Drafting assumes that both upper and lower values are positive. If you require either tolerance to be negative, start the value with a negative sign (-).

[Figure 124. Limit Tolerancing on page 236](#) shows an example of limit tolerancing.

Figure 124. Limit Tolerancing

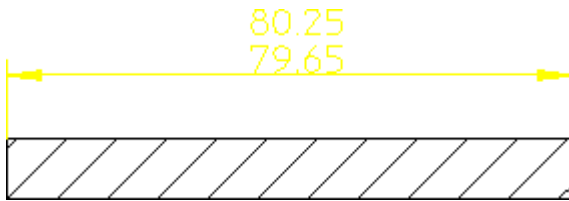

To add a limit tolerance:

1. Press **DIMENSION 1**.
2. Pick **Limit** in **Tolera**.
3. Enter the upper limit tolerance value, or string.
4. Enter the lower limit tolerance value, or string.

Clearing the Current Tolerance

You can interrupt a dimensioning command to clear the currently active tolerance string. Subsequently assigned dimensions will not have a tolerance string.

To clear the current tolerance:

1. Press **DIMENSION 1** and pick **CLEAR** in **Tolera**.
2. Complete the dimensioning command.

Creo Elements/Direct Drafting draws the dimension text without a tolerance string.

To cancel the function and leave the dimensioning command active, press **CLEAR**.

Predefining Prefixes, Postfixes, Superfixes, Subfixes, and Tolerances

If you frequently add such things as postfixes to a dimension, it is useful to first predefine them. Once defined, they can easily be selected from a table. Apart from making the process quicker, it also improves consistency.

Although the following example is for a prefix, the procedure is the same for a postfix, a superfix, a subfix, and a tolerance.

1. Pick Prefix in **DIMENSION 1**.
2. Pick **ADD** in the **PREFIX** menu.
3. Enter:
FC2:0.01
4. Enter 0.5 for the text scale.

- Enter:
FC2:0.01

Each time you pick a dimension, you can select the desired prefix from the list.

To give a dimension a prefix:

- Pick **SINGLE** in **DIMENSION 1**.
- Pick **Prefix**.
- Pick the prefix you want from the list.
- Identify the begin and end points of the dimension.

Figure 125. Drawing Prefixes

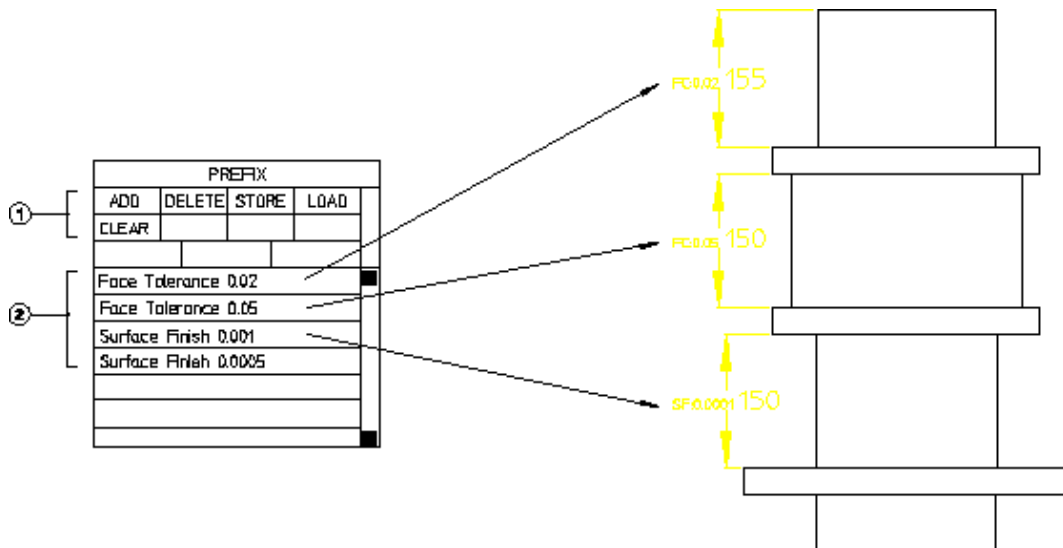

The other commands available are:

DELETE	Deletes the item from the table. First pick DELETE and then pick the row.
STORE	Stores the table in a file that can be recalled later.
LOAD	Recalls a stored table.

Selection Filtering

When you assign dimensions to multiple drawing elements at one time, you can also apply a selection filter. The selection filter prevents elements that meet certain criteria from receiving dimensions. Selection filtering commands are located under **FILTER** on **DIMENSION 2**.

Drawing elements can be filtered on the basis of any combination of the following types of criteria:

-
- Geometry Type
 - Line Slope
 - Linetype
 - Pensize
 - Linesize
 - Color

Enabling and Disabling Selection Filtering

The selection filter can be turned on or off at any time. The Filter command on the **DIMENSION 1** menu enables and disables selection filtering. The filter setting toggles from On to Off each time you pick Filter. The current filter setting is displayed in the block next to the Filter command.

Setting up the Selection Filter

Before you can use the selection filter, you must specify the filter criteria. You can combine options from any of the categories below to come up with a filter that meets your needs.

1. Pick FILTER from the **DIMENSION 2** menu.
2. Pick a filter type:
 - GEOM TYPE
 - LINE SLOPE
 - LINETYPE
 - PENSIZE
 - LINESIZE
 - COLOR
3. Pick the desired options for this filter type.
4. If needed, pick other filter type and options until the selection filter is complete.

Geometry-Type Filter

This filter excludes elements based on their geometry type. For example, if the Arc and Circle options are set, all circular elements will be excluded by this filter.

To set the geometry-type filter:

1. Pick FILTER from the **DIMENSION 2** menu.
2. Pick the GEOM TYPE filter.

-
3. Select one or more geometry types to add them to the filter. Types currently in the filter are highlighted. Pick Clear to quickly remove all geometry types from the filter. Pick NOT to reverse the sense of the current filter.

The GEOM TYPE options are:

- Line
- Point
- Arc
- Fillet
- Circle
- Text
- Spline
- BSpline

The Line Slope Filter

The line-slope filter is a table of angle ranges. Each entry in the table has a lower bound and an upper bound, given in the current angular units. Linear elements with orientations that fall within the angle range of any entry in the table are excluded by this filter.

For example, if the orientation filter contains one entry with a lower bound of 30 degrees and an upper bound of 40 degrees, all lines with 33 degree elevations will be filtered, but lines with 45 degree elevations will remain.

Adding To The Line-Slope Filter

1. Pick FILTER from the **DIMENSION 2** menu.
2. Pick the LINE SLOPE filter.
3. Pick CREATE Horizontal
4. Enter the lower bound (in current angular units).
5. Enter the upper bound (in current angular units).

Creo Elements/Direct Drafting creates a new entry in the filter table.

6. Press END to finish the operation.

To quickly add an entry for horizontal or for vertical lines, you can pick CREATE Horizontal or CREATE Vertical.

Deleting from The Line-Slope Filter

1. Pick FILTER from the **DIMENSION 2** menu.
2. Pick the LINE SLOPE filter.

-
3. Pick DELETE
 4. Identify the table entry to delete by picking it.

Creo Elements/Direct Drafting deletes the entry from the filter table.

5. Press END to finish the operation.

To quickly remove the entry for a horizontal or vertical line, you can pick DELETE Horizontal or DELETE Vertical.

The Linetype Filter

This filter excludes elements based on their linetype. For example, if the Dashed option is set, all elements with a dashed linetype will be excluded by this filter.

To set the linetype filter:

1. Pick FILTER from the **DIMENSION 2** menu.
2. Pick the LINETYPE filter.
3. Select one or more linetypes to add them to the filter. Types currently in the filter are highlighted. Pick Clear to quickly remove all linetypes from the filter. Pick NOT to reverse the sense of the current filter.

The LINETYPE options are:

- SOLID
- DOTTED
- DASHED
- LONG_DASHED
- DOT_CENTER
- DASH_CENTER
- PHANTOM
- CENTER_DASH_DASH

The Pensize and Linesize Filter

The pensize and linesize filters are tables of size ranges. Each entry in the table has a lower bound and an upper bound, given in the current distance units. Elements with sizes that fall within the range of any entry in the table are excluded by this filter.

For example, if the pensize filter contains one entry with a lower bound of .5 mm and an upper bound of 1.0 mm, and a second entry with bounds of 1.1 mm and 3.0 mm, all lines with sizes between .5 mm and 3.0 mm will be filtered except for lines with sizes between 1.0 mm and 1.1 mm.

Adding to the Pensize or Linesize Filter

1. Pick FILTER from the **DIMENSION 2** menu.
2. Pick the PENSIZE or LINESIZE filter.
3. Pick CREATE
4. Enter the lower bound.
5. Enter the upper bound.

Creo Elements/Direct Drafting creates a new entry in the filter table.

6. Press END to finish the operation.

Deleting from the Pensize or Linesize Filter

1. Pick FILTER from the **DIMENSION 2** menu.
2. Pick the PENSIZE or LINESIZE filter.
3. Pick DELETE
4. Identify the table entry to delete by picking it.

Creo Elements/Direct Drafting deletes the entry from the filter table.

5. Press END to finish the operation.

The Color Filter

The color filter is a table of colors. Elements with colors that match any entry in the table are excluded by this filter.

Adding An Entry

1. Pick FILTER from the **DIMENSION 2** menu.
2. Pick the COLOR filter.
3. Pick CREATE
4. Enter the name of the color to add to the filter.

Creo Elements/Direct Drafting creates a new entry in the filter table.

5. Press END to finish the operation.

Deleting An Entry

1. Pick FILTER from the **DIMENSION 2** menu.
2. Pick the COLOR filter.
3. Pick DELETE
4. Identify the table entry to delete by picking it.

Creo Elements/Direct Drafting deletes the entry from the filter table.

-
5. Press END to finish the operation.

Clearing the Selection Filter

To clear all filter criteria from the selection filter:

1. Pick FILTER from the **DIMENSION 2** menu.
2. Pick RESET.
3. Enter "confirm" to complete the operation.

Saving and Loading Selection Filters

You can use the SAVE and LOAD commands to save selection filters to files and later reload them into Creo Elements/Direct Drafting.

To save the current selection filter:

1. Pick FILTER from the **DIMENSION 2** menu.
2. Pick SAVE.
3. Enter a filename ("Select_filter.1", for example).

Creo Elements/Direct Drafting will store the selection filter under the given filename.

To load a new selection filter from a file (overwriting any current filter):

1. Pick FILTER from the **DIMENSION 2** menu.
2. Pick LOAD.
3. Enter a filename ("Select_filter.1", for example).

Creo Elements/Direct Drafting will load the named selection filter, replacing any current filter.

Naming a Selection Filter

You can assign a name to the current selection filter to help you identify it. The name appears in the menu block next to the NAME command. If you change any part of a named selection filter, the name is removed.

To assign a name to a selection filter:

1. Pick FILTER from the **DIMENSION 2** menu.
2. Pick NAME.
3. Enter a filter name ("Filter.1", for example).

Creo Elements/Direct Drafting indicates the filter name on the screen menu.

Setting and Changing Dimensioning Attributes

DIMENSION 3 commands allow you to set text and line attributes for subsequent dimensioning operations and to change these settings for existing dimensioning in your drawings. The four top-level commands on this menu are SET LINES, SET TEXTS, CHG LINES, and CHG TEXTS. Each calls up a menu of commands that set or change specific features of dimensioning lines and texts.

The current dimensioning style settings are displayed in the style display window near the bottom of the menu whenever you set new dimensioning attributes. The preview allows you to quickly confirm the dimensioning style that will be used for subsequent dimensioning.

Setting Line Attributes

SET LINES gives you access to the commands that set attributes of dimension lines. These settings will be applied to all subsequent dimensioning that you assign in the **DIMENSION 1** menu. The commands available under SET LINES are:

SET ARROW	Sets the type, size, and fill attributes for dimension line terminators.
SET COLOR	Sets the color for extension lines, dimension lines, and text frames.
SET WIDTH	Sets the width for all subsequent dimension lines.
OFFSET PNT	Sets the offset distance between a geometry feature and the dimensioning extension lines.
OFFSET LIN	Sets the distance between the top end of the extension line and the dimension line.
DATUM STEP	Sets the vertical distance (or step) that is automatically placed between datum dimension lines drawn with DATUM AUTO.
MIN SPACE	Sets the minimum distance allowed between a geometry feature and its dimension line.
CATCH LINE	Sets whether or not a dimension may be selected by picking its dimension line, extension line, or text.
BROKEN	Sets whether or not a line is drawn between the extension lines of a dimension when the dimension text is placed outside of the extension lines.

Setting Terminators

This section shows how to set the type, size, and fill attributes for all subsequent dimension line terminators.

Normally, the terminator is an arrowhead.

Figure 126. Dimension Line Terminators on page 244 shows the five possible dimension line terminators:

Figure 126. Dimension Line Terminators

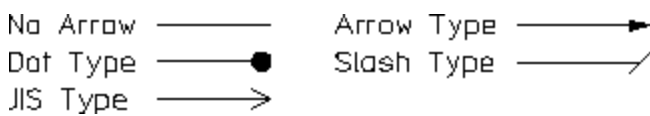

To set the dimension line terminator:

1. Pick SET LINES from the **DIMENSION 3** screen menu.
2. Pick SET ARROW and either Both, First or Second.
3. Pick terminator attributes in OPTIONS.

Creo Elements/Direct Drafting uses these settings for all subsequent dimensions. If needed, the style display window is also updated to show the newly-set terminators.

You can set the first, the second or both terminators using the SET ARROW options:

- Both
- First
- Second

Both

Both is the default option. Pick Both and then pick the required attributes. The settings you select will apply to both dimension line terminators.

First

Pick First to apply the chosen terminator settings to the first point you pick when identifying the dimension start-point.

Second

Pick Second to apply the chosen terminator settings to the second point you pick when identifying the dimension end-point.

Figure 127. Dimension Terminators – First and Second

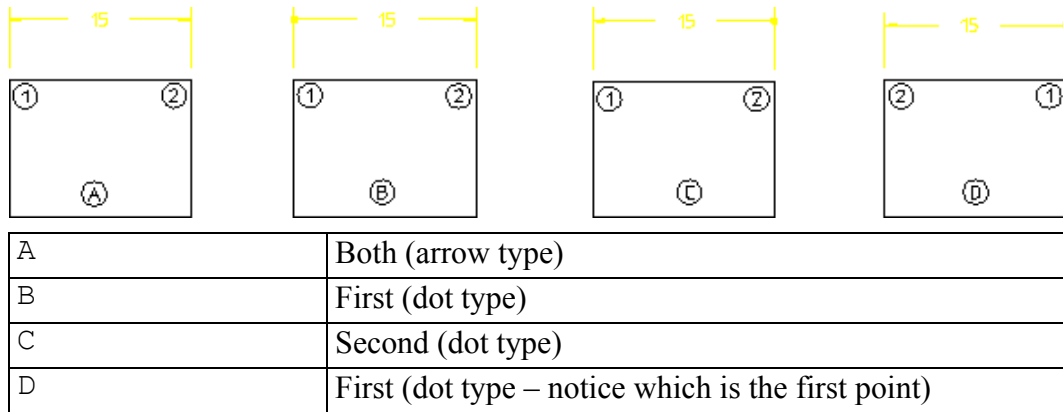

Because you specify a first point and a second point, it makes no difference if the dimensions are horizontal or vertical.

Selecting Terminator Attributes

After selecting the dimension line terminator to be set, you then select the attributes for that terminator from **OPTIONS**.

- Fill On
- Size Rel
- Fill Off
- Size Abs
- No Arrow
- Arrow Type
- Dot Type
- Slash Type
- JIS Type
- Inside
- Outside
- Auto

As you set the various terminator options, the style display window is updated to reflect the current dimensioning settings.

Filling Terminators

This is the default option.

To fill a terminator:

1. Pick **SET LINES** from the **DIMENSION 3** screen menu.

-
2. Pick SET ARROW and either Both, First, or Second.
 3. Pick Fill On to fill the arrowhead and dot type terminators for all subsequent dimensions.
 4. Pick either Arrow Type or Dot Type in OPTIONS.

Relative Size

You can set the size of the dimension line terminator by entering a scale factor relative to the main dimension text size.

The Creo Elements/Direct Drafting default scale factor is 1 and the default main dimension text size is 3 . 5 mm.

To set the relative size of the dimension line terminator:

1. Pick SET LINES from the **DIMENSION 3** screen menu.
2. Pick SET ARROW and either Both, First, or Second.
3. Pick Size Rel in OPTIONS.
4. Enter a scale factor.
5. Pick either Arrow Type, Dot Type, Slash Type, or JIS Type in OPTIONS.

Filling Off

To turn fill off for arrowhead and dot type terminators for all subsequent dimensions:

1. Pick SET LINES from the **DIMENSION 3** screen menu.
2. Pick SET ARROW and either Both, First, or Second.
3. Pick Fill Off to turn fill off for arrowhead and dot type terminators for all subsequent dimensions.
4. Pick either Arrow Type or Dot Type in OPTIONS.

Size Absolute

The Creo Elements/Direct Drafting default terminator size is 3 . 5.

To set the absolute size of the terminator:

1. Pick SET LINES from the **DIMENSION 3** screen menu.
2. Pick SET ARROW and either Both, First, or Second.
3. Select Size Abs in OPTIONS.
4. Enter a size value.
5. Pick either Arrow Type, Dot Type, Slash Type, or JIS Type in OPTIONS.

No Terminators

To draw dimension lines without terminators:

1. Pick SET LINES from the **DIMENSION 3** screen menu.
2. Pick SET ARROW and either Both, First, or Second.
3. Pick No Arrow in OPTIONS.

Selecting a Terminator Type

You can select one of four terminator types:

1. Pick SET LINES from the **DIMENSION 3** screen menu.
2. Pick SET ARROW and either Both, First, or Second.
3. Pick either Arrow Type, Dot Type, Slash Type, or JIS Type in OPTIONS.

Example

Figure 128. Unfilled dot type Terminators on page 247 shows unfilled dot type terminators.

Figure 128. Unfilled dot type Terminators

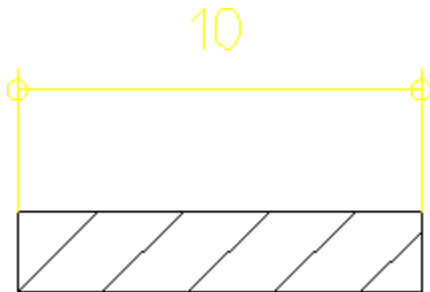

To set unfilled dot type terminators for all subsequent dimensions:

1. Pick SET LINES from the **DIMENSION 3** screen menu.
2. Pick SET ARROW and Both.
3. Pick Fill Off in OPTIONS.
4. Pick Dot Type in OPTIONS.

Creo Elements/Direct Drafting will use an unfilled dot type terminator for all subsequent dimensions.

Setting Terminator Position

By default, the position of terminators with respect to the extension lines is determined automatically. If there is enough room between the dimension's extension lines for the terminators and dimension text, the terminators are placed between the extension lines. Otherwise, terminators are placed outside of the extension lines. The terminator position can also be set manually.

To set the terminator position:

1. Pick SET LINES from the **DIMENSION 3** screen menu.
2. Pick SET ARROW.
3. Select Inside, Outside, or Auto in OPTIONS.

Setting Dimension Geometry Color

This section shows how to set the color of the extension lines, and dimension lines for all subsequent dimensions.

To set a dimension color:

1. Pick SET LINES from the **DIMENSION 3** screen menu.
2. Pick SET COLOR.
3. Creo Elements/Direct Drafting sets the color for all subsequent dimension geometry. If needed, the style display window is updated to show the newly-selected dimensioning color.

Setting the Dimension-Line Pensize

1. Pick SET LINES from the **DIMENSION 3** screen menu.
2. Pick SET PENSIZ.
3. Enter a value.

Creo Elements/Direct Drafting sets this size for all subsequent dimensions. The style display window is updated to show the new line size.

Example

To set the dimension-line size to 0.25 mm:

1. Press **DIMENSION** and pick the SET LINES menu.
2. Pick SET PENSIZ.
3. Enter .25.

Creo Elements/Direct Drafting sets the width to 0.25 mm.

4. Press **DIMENSION** and pick a dimension option.

Figure 129. Dimension-Line Pensize

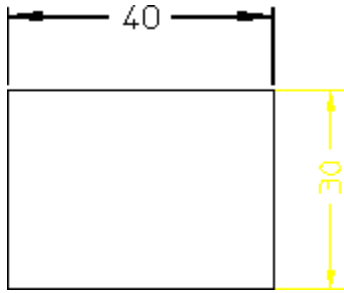

Setting the Offset Point

Various national standards are used for dimensioning (American Standards, British Standards, and so on). You can set the distance (or offset) between the geometry feature and the dimension extension lines to conform to the standards you use. The Creo Elements/Direct Drafting default for this distance is 0 mm.

To set the dimension offset point distance:

1. Pick SET LINES from the **DIMENSION 3** screen menu.
2. Pick OFFSET PNT.
3. Enter any positive value for the distance.

Creo Elements/Direct Drafting sets this offset distance for all subsequent dimensions. The style display window is updated to show the new offset distance if necessary.

Example

To set the distance between a geometry feature and the dimension extension lines to 1.5 mm:

1. Pick SET LINES from the **DIMENSION 3** screen menu.
2. Pick OFFSET PNT.
3. Enter 1 . 5.

Creo Elements/Direct Drafting sets the offset distance to 1.5 mm for all subsequent dimensions.

[Figure 130. Dimension Offset Point on page 250](#) shows the dimension offset point.

Figure 130. Dimension Offset Point

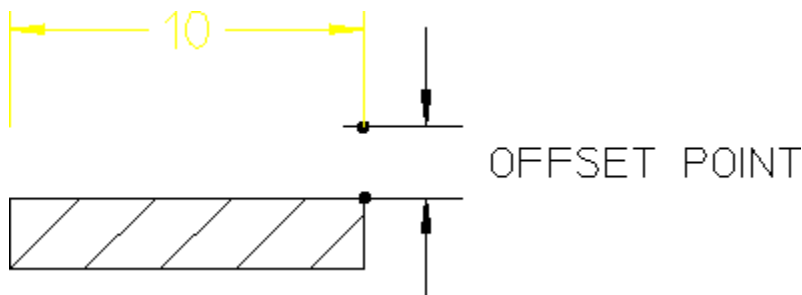

Setting Dimension Offset

Various national standards are used for dimensioning (American Standards, British Standards, and so on). You can set the distance (or offset) between the top end of the extension line and the dimension line to conform to the standards you use. The Creo Elements/Direct Drafting default for this distance is 2 mm.

To set the dimension offset:

1. Pick SET LINES from the **DIMENSION 3** screen menu.
2. Pick OFFSET LIN.
3. Enter a positive value for the distance.

Creo Elements/Direct Drafting sets this distance for all subsequent dimensions. The style display window is updated if necessary to reflect the change.

Example

To set the distance between the top end of the extension line and the dimension line to 3 mm:

1. Pick SET LINES from the **DIMENSION 3** screen menu.
2. Pick OFFSET LIN.
3. Enter 3.

Creo Elements/Direct Drafting sets the offset distance to 3 mm for all subsequent dimensions.

[Figure 131. Dimension Offset Line Distance on page 251](#) shows the dimension offset line distance.

Figure 131. Dimension Offset Line Distance

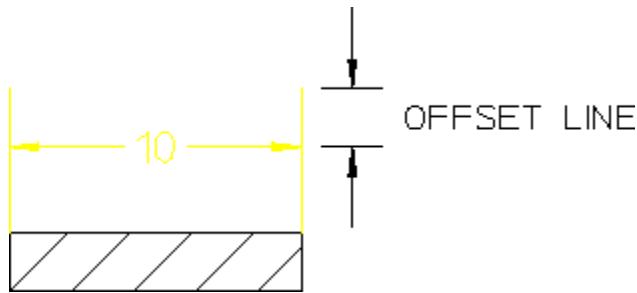

Stepping Datum Dimension Text Automatically

You may find that your datum dimensions are positioned too close together. This section shows how to specify a vertical distance (or step) between each subsequent datum dimension line.

The Creo Elements/Direct Drafting default for this distance is 8 mm. The distance is active for the DATUM LONG and DATUM SHRT commands (with the option DATUM AUTO).

To specify a datum step:

1. Pick SET LINES from the **DIMENSION 3** screen menu.
2. Pick DATUM STEP.
3. Enter a new distance for the datum step.

Creo Elements/Direct Drafting sets the vertical distance to the new value. The new step value is also shown in the style display window.

4. Complete, or start the dimensioning command.

Creo Elements/Direct Drafting steps the dimension line for each dimension.

Example

Figure 132. Datum Stepping on page 252 shows the difference between:

- Datum dimensioning without using DATUM STEP (datum step distance is 0). This produces a poor quality dimension where the dimension text has been overwritten by the dimension lines.
- Datum dimensioning using DATUM STEP (datum step distance is 10).

Figure 132. Datum Stepping

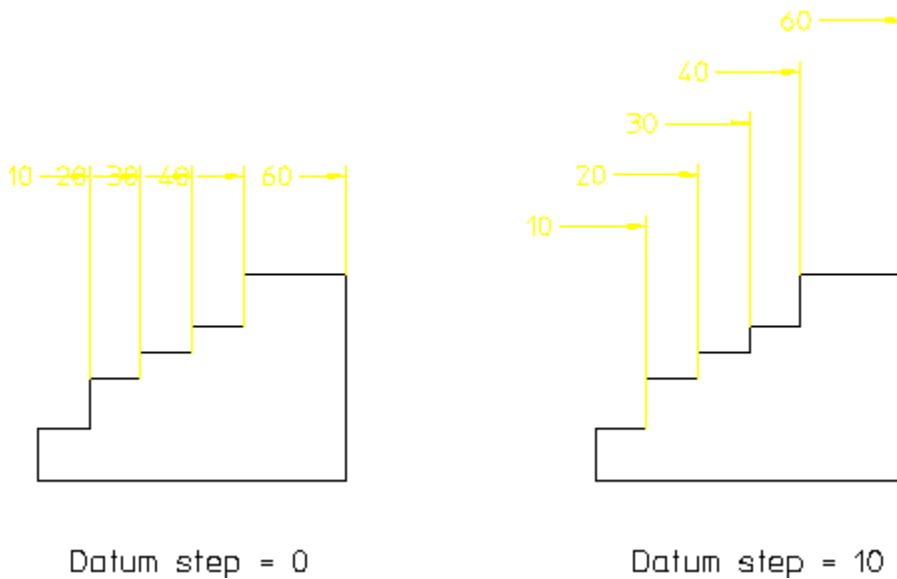

Setting Minimum Space

This section shows how to avoid crowding dimensions by setting a minimum distance (or space) between the geometry feature you are dimensioning and the dimension line. If you try to locate the dimension trace closer than the minimum distance, the trace will skip to the opposite side of the geometry feature. The Creo Elements/Direct Drafting default for this distance is 0 mm.

To set the minimum space:

1. Pick SET LINES from the **DIMENSION 3** screen menu.
2. Pick MIN SPACE.
3. Enter a minimum distance value.

Example

The following example shows how to set a typical minimum distance (10 mm) between the dimension line and geometry feature:

1. Pick SET LINES from the **DIMENSION 3** screen menu.
2. Pick MIN SPACE.
3. Enter a value of 10.
4. Complete or start a dimensioning command.

Refer to [Figure 133. Locating a Dimension – Closer Than the Minimum Distance on page 253](#). If you try to locate the dimension text closer than the minimum distance (10mm), the dimension skips to the opposite side of the geometry feature.

Figure 133. Locating a Dimension – Closer Than the Minimum Distance

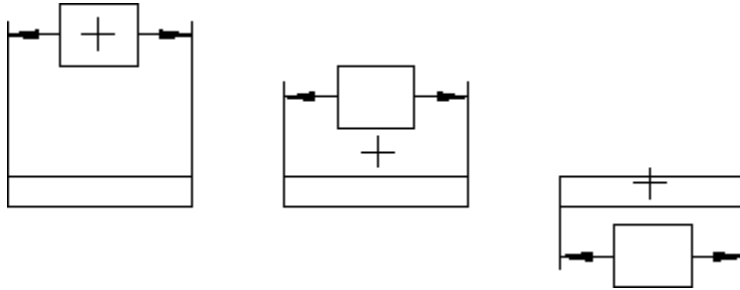

Catching Lines

When you want to pick a dimension, you can specify which components of the dimension can be selected. This is done with the `CATCH LINE` command which can be toggled between on and off:

On	A dimension may be selected by picking one of the dimension components: <ul style="list-style-type: none"> • Dimension line • Extension line • Dimension text This is the default.
Off	A dimension may be picked by picking the dimension text only.

Drawing Dimension Lines Inside Extension Lines

Because of space limitations when dimensioning, you might want to place dimension text outside the extension lines, but still want the dimension lines to be drawn inside the extension lines.

To draw an unbroken dimension line inside the extension lines:

1. Pick `SET LINES` from the **DIMENSION 3** screen menu.
2. Pick `BROKEN` and `BROKEN OFF`.
3. Complete or start the dimensioning command.

[Figure 134. Dimension Lines Inside Extension Lines on page 254](#) shows dimension lines drawn inside the extension lines and dimension text outside.

Figure 134. Dimension Lines Inside Extension Lines

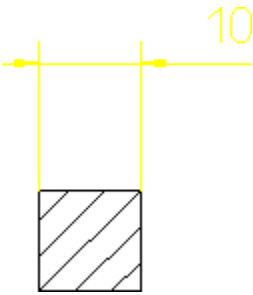

Drawing Dimension Lines Outside Extension Lines

Because of space limitations you might want to place dimension lines and text outside the extension lines.

To draw a broken dimension line outside the extension lines:

1. Pick SET LINES from the **DIMENSION 3** screen menu.
2. Pick BROKEN and BROKEN ON.
3. Complete or start the dimensioning command.

[Figure 135. Dimension Lines and Text Outside Extension Lines on page 254](#) shows how dimension lines and text are drawn outside the extension lines.

Figure 135. Dimension Lines and Text Outside Extension Lines

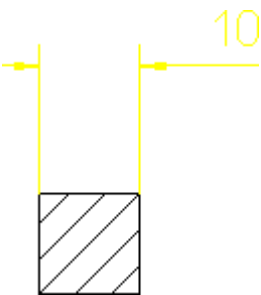

Setting Text Attributes

SET TEXTS gives you access to the commands that set attributes of dimension text. These settings apply to all subsequently applied dimensioning. The commands available under SET TEXTS are:

SET TEXT	Sets text appearance attributes such as size, font, slant, and aspect ratio.
SET FORMAT	Sets the format for values in dimensions.
SET UNITS	Sets the units used for the upper and/or lower dimensioning text.

SET FRAME	Determines what kind, if any, box is drawn around subsequent dimensioning text.
SET DIMLOC	Sets the location of the dimension text relative to the dimension line.
SET ORIENT	Sets the orientation of dimension text relative to the dimension line.
SET OFFSET	Sets the offset distance between dimensioning text and the dimension line.
SET SPACE	Sets the distance between the ends of the dimension line and the dimension text.
SET CATCH	Sets the size of the catch range used to automatically center dimensioning text between extension lines.

Dimension text is comprised of several components:

- Prefix
- Dimension value
- Tolerance
- Postfix

To set the dimension text appearance:

1. Pick SET TEXTS from the **DIMENSION 3** screen menu.
2. Pick SET TEXT.
3. Pick a text component to set. By default all components are affected.
4. Pick the attributes in the OPTIONS list.

Creo Elements/Direct Drafting uses these settings for all subsequent dimensions.

The SET TEXT components are:

- All (prefix, value, tolerance and postfix)
- Lower
- Upper
- Lower Val
- Upper Val
- Lower Tol
- Upper Tol
- Prefix
- Postfix

Selecting the Text Attributes

Once you have selected the text components, select the required attributes from OPTIONS:

- Size Abs
- Font
- Size Rel
- Slant
- Ratio
- Brackets (only visible after Lower or Upper)
- **COLOR**

Absolute Text Size

This is the default option.

To set the absolute size of dimension text:

1. Pick SET TEXTS from the **DIMENSION 3** screen menu.
2. Pick SET TEXT and the component to set.
3. Pick Size Abs in OPTIONS.
4. Enter a new text size.

Creo Elements/Direct Drafting sets the text size for the selected dimension text components. The style display window is also updated to show any change in text size.

Text Font

The Creo Elements/Direct Drafting default font is `osd_default`. Refer to [Setting Fonts on page 334](#) for a list of font names.

To change the dimension text font:

1. Pick SET TEXTS from the **DIMENSION 3** screen menu.
2. Pick SET TEXT and the component to set.
3. Pick Font in OPTIONS.
4. Enter a font name (in quotes ' ' or " ").

Creo Elements/Direct Drafting sets the font for the selected dimension text components. The style display window is also updated to show any font change.

Relative Text Size

Creo Elements/Direct Drafting multiplies the relative factor by the current main dimension text size, this gives a new text size for all selected dimension text.

To set a relative text size:

1. Pick SET TEXTS from the **DIMENSION 3** screen menu.
2. Pick SET TEXT and the component to set.
3. Pick Size Rel in OPTIONS.
4. Enter a relative factor for the text size.

Creo Elements/Direct Drafting sets the relative text size for the selected dimension text components.

Text Slant

The Creo Elements/Direct Drafting default slant is 0 degrees.

To set the text slant:

1. Pick SET TEXTS from the **DIMENSION 3** screen menu.
2. Pick SET TEXT and the component to set.
3. Pick Slant in OPTIONS.
4. Enter a new slant angle.

Creo Elements/Direct Drafting sets the slant for the selected dimension text components. The style display window is updated if needed to show any change in text slant.

Character Width to Height Ratio

The Creo Elements/Direct Drafting default is 1. A number less than one produces thin characters, a number greater than one produces thick characters.

To change the character width to height ratio:

1. Pick SET TEXTS from the **DIMENSION 3** screen menu.
2. Pick SET TEXT and the component to set.
3. Pick Ratio in OPTIONS.
4. Enter the new value.

Creo Elements/Direct Drafting sets the aspect ratio for the selected dimension text components. The style display window is updated if needed to show any change in text appearance.

Fill

This option fills characters of block fonts.

Brackets

Primary and secondary dimension text can be enclosed in brackets [] or not. By default, brackets are not on.

To set brackets on or off:

1. Pick SET TEXTS from the **DIMENSION 3** screen menu.
2. Pick SET TEXT and either Upper or Lower.
3. Pick Brackets in OPTIONS.
4. Enter ON or OFF.

The style display window is updated if needed to show any change in text appearance.

Text Color

To select dimension text color:

1. Pick SET TEXTS from the **DIMENSION 3** screen menu.
2. Pick SET TEXT and the component to set.
3. Enter a color name at the command prompt.

Example

In this example the following text attributes are set:

- All postfix text will have a slant of 30 degrees.
- All dimension text will have an absolute size of 10 mm.

To set the text attributes as above:

1. Pick SET TEXTS from the **DIMENSION 3** screen menu.
2. Pick SET TEXT and Postfix.
3. Pick Slant in OPTIONS.
4. Enter 30.

Creo Elements/Direct Drafting sets the postfix text slant to 30 degrees.

5. Pick All in SET TEXT.
6. Pick Size Abs in OPTIONS.
7. Enter 10.

Creo Elements/Direct Drafting sets the size of all dimension text to 10 mm.

Setting the Dimension Text Format

This section shows how to set the format for subsequent dimension values.

The format for metric, angular, and decimal inches (for example, 2 . 1) is defined using a format string. The format for fractional inches (for example, 1 / 16) is defined using a format value and a format string.

Format String

The format string defines:

- The type of decimal period: a comma (,) or point (.).
- The suppression of zeroes before the decimal period (left zero suppression).
- The suppression of zeroes after the decimal period (right zero suppression).
- The number of decimal places.

Creo Elements/Direct Drafting has a default format string which defines:

- The decimal period as a point (.).
- No left zero suppression. For example, 0 . 21 appears as 0 . 21.
- Right zero suppression. For example, 2 . 100 appears as 2 . 1.
- The dimension value to be displayed to two decimal places.

For example, 2 . 2354 appears as 2 . 24 and 12 . 299 appears as 12 . 3 (notice the right zero suppression).

This format is general and may not suit certain types of dimensioning. For example: large scale dimensions, precision dimensions, and so on. Using the SET FORMAT command you can enter your own format string.

Format Value

The format for fractional inches is defined using a format value and a format string. The format value defines the highest denominator for the fractions, for example, 128. The Creo Elements/Direct Drafting default is 64. Allowable values are: 2, 4, 8, 16, 32, 64, and 128.

[Table 6. Format Strings on page 260](#) explains the format string using six examples of how Creo Elements/Direct Drafting would display 10 . 000, 3 . 142, and 0 . 090.

Table 6. Format Strings

Format String	Represents
'1, '	Dimension values with a decimal comma, left zeroes not suppressed, right zeroes suppressed, and no decimal places quoted. Creo Elements/Direct Drafting displays the values 10, 3, and 0.
'0.1 '	Dimension values with a decimal point, left zeroes not suppressed, right zeroes suppressed, and one decimal place quoted. Creo Elements/Direct Drafting displays the values 10, 3.1, and 0.1.
'1,1 '	Dimension values with a decimal comma, both left and right zeroes suppressed, and one decimal place quoted. Creo Elements/Direct Drafting displays the values 10, 3,1, and ,1.
'1.000 '	Dimension values with a decimal point, with left zero suppression, right zeroes not suppressed, three decimal places quoted. Creo Elements/Direct Drafting displays the values 10.000, 3.142, and .090.
'0,001 '	Dimension values with a decimal comma, left zeroes not suppressed, right zeroes suppressed, three decimal places quoted. Creo Elements/Direct Drafting displays the values 10, 3,142, and 0,09.
' +1,001 '	Dimension values with a decimal comma, with left and right zero suppression, three decimal places quoted, plus included in value. Creo Elements/Direct Drafting displays the values +10, +3,142, and +,09.

To set the dimension text format:

1. Pick SET TEXTS from the **DIMENSION 3** screen menu.
2. Pick SET FORMAT, then pick the required units in OPTIONS.
3. Enter the format string (in quotes ' ' or " "), or for fractions, the format value and format string (in quotes ' ' or " ").

Creo Elements/Direct Drafting sets the format for all subsequent dimension values. If necessary, the style display window is also updated to show the newly-set dimension format.

Setting Dimension Units

This section shows how to set upper or lower dimension text units to any of the units in the OPTIONS list.

To set dimension text units:

1. Pick SET TEXTS from the **DIMENSION 3** screen menu.
2. Pick SET UNITS
3. Pick the component of dimension text in SET UNITS.
4. Pick the new units in OPTIONS.

The SET UNITS text components are:

- Upper Dim
- Lower Dim

Upper Dimension

This is the default option. Pick Upper Dim to set the units for the main dimension text.

Lower Dimension

Pick Lower Dim to set the units for the lower dimension text (if lower text is present).

Selecting the Units

First select the dimension text component, then select the new units for that component from the options available:

- um
- mm
- cm
- Meters
- km
- Degree
- Radian
- Dg Min Sec
- Inches
- Frct inch
- Ft fr inch

-
- Ft fr in s
 - Ft fr in t
 - None

um

Pick um to set the dimension unit to micrometers.

mm

This is the default option. Pick mm to set the dimension units to millimeters.

cm

Pick cm to set the dimension units to centimeters.

Meters

Pick Meters to set the dimension units to meters.

km

Pick km to set the dimension units to kilometers.

Inch

Pick Inch to set the dimension units to inches.

Frct inch (Fractional Inches)

Pick Frct inch to set the dimension units to fractional inches. For example, 12 " and 6 1/2 ".

Ft fr inch (Feet and Fractional Inches)

Pick Ft fr inch to set the dimension units to feet and fractional inches. For example, 1 - 0 and 0 - 6 1/2.

Ft fr in s (Feet and Fractional Inches with Sign)

Pick Ft fr in s to set the dimension units to feet and fractional inches. Creo Elements/Direct Drafting displays the dimension value with feet and inches signs. For example, 1' - 0" and 0' - 6 1/2".

Ft fr in t (Feet and Fractional Inches with Text)

Pick Ft fr in t to set the dimension units to feet and fractional inches. Creo Elements/Direct Drafting displays the dimension value with feet and inches indicated by text. For example, 1 FT 0 IN and 0 FT 6 1/2 IN.

Degree

Pick Degree to set the angle dimension units to degrees.

Radian

Pick Radian to set the angle dimension units to radians.

Dg Min Sec (Degrees Minutes Seconds)

Pick Dg Min Sec to set the angle dimension units to degrees, minutes, and seconds.

None

To switch off dual dimensioning:

1. Pick Lower in SET UNITS.
2. Pick None in OPTIONS.

Creo Elements/Direct Drafting switches the dual dimensioning off.

Setting the Dimension Text Frame

This section shows how to set the dimension text frame. All the dimensions created after setting a dimension text frame inherit the text frame.

- Off
- Balloon frame
- Box frame
- Flag frame
- Basic Frame

To set the dimension text frame:

1. Pick SET TEXTS from the **DIMENSION 3** screen menu.
2. Pick SET FRAME.
3. Pick Off, Balloon, Box, or Flag.

Creo Elements/Direct Drafting sets the necessary frame around the dimension text. If necessary, the style display window is updated to show the newly-selected text frame.

The basic dimension text frame allows you to have a frame just around the dimension main text; by that you can mark all basic dimensions in your drawing. In addition to that Creo Elements/Direct Drafting enables you to include a user-defined portion of the prefix and postfix text into the basic frame in addition to the

normal prefix and postfix text outside the frame. You can add and edit both, the basic and normal prefix and postfix text. You can also convert an existing dimension text frame to a basic dimension text frame.

Figure 136. Dimension Text Frame — Options on page 264 shows the four SET FRAME options.

Figure 136. Dimension Text Frame — Options



Setting a Dimension's Location

The location of dimension can be in one of three positions:

- On the dimension line (location 1).
- Above the dimension line (location 2). This is the default.
- Below the dimension line (location 3).

Figure 137. Dimension Location

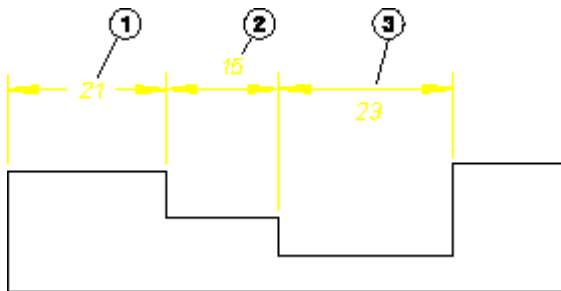

To set the location of dimension text:

1. Pick SET DIMLOC in SET TEXTS (**DIMENSION 3** menu).
2. Pick one of the following in SET DIMLOC:
 - On Line
 - Above Line
 - Below Line

All subsequent dimensions are drawn to the specified dimension location.

Setting a Dimension's Orientation

The orientation of the dimension text can be one of the following:

- Parallel to the dimension line (location 1). This is the default.

- Horizontal (location 2).
- Vertical (location 3).
- Perpendicular to the dimension line (location 4).

Figure 138. Dimension Orientation

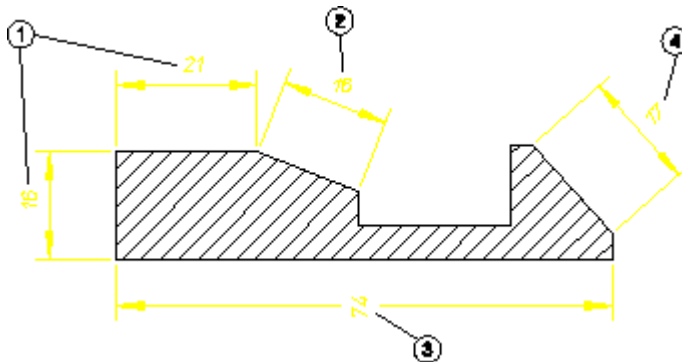

To set the orientation of dimension text:

1. Pick SET ORIENT in SET TEXTS (**DIMENSION 3** menu).
2. Pick one of the following in SET ORIENT:
 - Parallel
 - Horizontal
 - Vertical
 - Perpend

All subsequent dimensions are drawn to the specified dimension orientation.

Setting Dimension Text Offset

Note

This function only works if you have previously selected either Above Line or Below Line in SET DIMLOC.

Figure 139. Dimension Text Offset on page 266 shows the distance (or offset) between the dimension line and dimension text. The Creo Elements/Direct Drafting default for this distance is 2 mm.

Figure 139. Dimension Text Offset

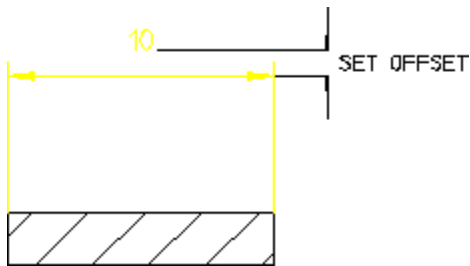

To set the dimension text offset:

1. Pick SET TEXTS from the **DIMENSION 3** screen menu.
2. Pick SET OFFSET.
3. Enter a positive offset value.

Creo Elements/Direct Drafting sets the offset distance. The style display window is updated if necessary to reflect the change.

Example

To set the distance between the dimension line and the dimension text to mm:

1. Pick SET TEXTS from the **DIMENSION 3** screen menu.
2. Pick SET OFFSET.
3. Enter 5.

Creo Elements/Direct Drafting sets the offset distance to 5 mm.

Setting Dimension Text Space

This section shows how to set the distance between the ends of the dimension lines and the dimension text.

Note

This function only works if you have previously picked On Line in SET DIMLOC.

Figure 140. [Distance between Dimension Lines and Text on page 267](#) shows the distance between the ends of the dimension lines and the dimension text. The Creo Elements/Direct Drafting default for this distance is 2 mm.

Figure 140. Distance between Dimension Lines and Text

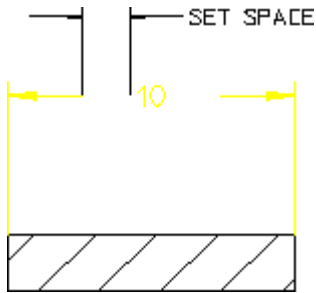

To set the distance between the ends of the dimension lines and the dimension text:

1. Pick SET TEXTS from the **DIMENSION 3** screen menu.
2. Pick SET SPACE.

Creo Elements/Direct Drafting prompts for a value

3. Enter a value.

Creo Elements/Direct Drafting sets the space for all subsequent dimension text. The style display window is updated if needed to reflect the change.

Example

To set the distance between the ends of the dimension lines and the dimension text to 3 mm:

1. Press **DIMENSION 1** and pick the SET TEXTS menu.
2. Pick SET SPACE.
3. Enter 3.

Creo Elements/Direct Drafting sets the distance to 3 mm.

Setting the Dimension Catch Range

This section shows how to center dimension text whenever you indicate a point within the catch range. The catch range is governed by two catch lines parallel to the extension lines. The origin is the bisection of the distance between the two extension lines and the catch range is the horizontal distance from the origin to the catch lines. If you indicate any point within the catch range, Creo Elements/Direct Drafting will center the dimension text exactly between the two extension lines.

[Figure 141. Dimension Catch Range on page 268](#) shows the catch range. Any point you indicate within the catch range results in Creo Elements/Direct Drafting centering the dimension text.

Figure 141. Dimension Catch Range

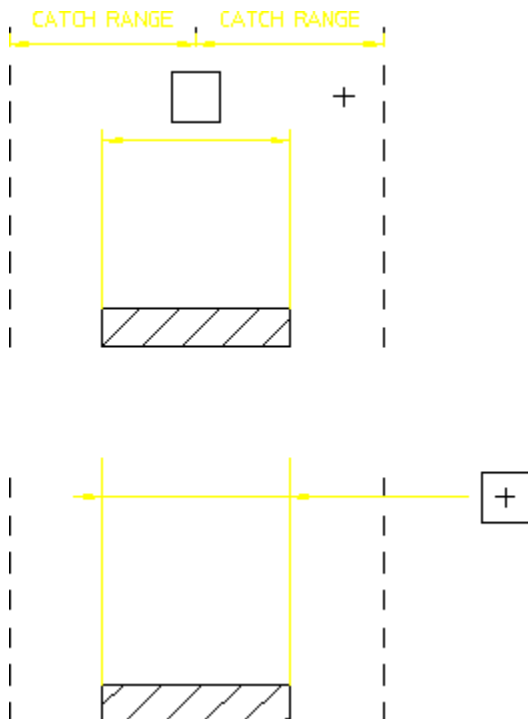

To set the dimension catch range:

1. Pick SET TEXTS from the **DIMENSION 3** screen menu.
2. Pick SET CATCH.
3. Enter a dimension catch range.

Creo Elements/Direct Drafting sets the catch range for all subsequent dimensions.

Setting the Coordinate Dimension Leading Zero

This section shows how to show or hide the leading zero in coordinate dimensions. By default, the leading zero is ON.

To set the leading zero in coordinate dimensions:

1. Pick SET TEXTS from the **DIMENSION 3** screen menu.
2. Pick one of the following in LEAD ZERO:
 - ON
 - OFF

Creo Elements/Direct Drafting sets the leading zero for all subsequent coordinate dimensions.

Changing Line Attributes

CHG LINES gives you access to the commands that change the attributes of existing dimension lines in your drawing. The commands available under CHG LINES are:

CHG FORMAT	Changes the format for values in selected dimensions.
CHG ARROW	Changes the type, size, and fill settings for selected dimension line terminators.
CHG COLOR	Changes the color for extension lines, dimension lines, and text frames.
CHG WIDTH	Changes the width of dimension lines.
OFFSET PNT	Changes the offset point.
OFFSET LIN	Changes the offset line.

Changing Dimension Text Format

This section shows how to change the format of an existing dimension value.

The format for metric, angular, and decimal inches (for example, 2 . 1) is defined using a format string. The format for fractional inches (for example, 1 / 1 6) is defined using a format value and a format string; both are explained fully in the [Setting the Dimension Text Format on page 259](#) section.

To change the format of an existing dimension value:

1. Pick **CHG LINES** from the **DIMENSION 3** screen menu.
2. Pick **CHG FORMAT** and either Upper Dim or Lower Dim.
3. Enter the format string (in quotes ' ' or " "), or for inch fractions, the format value and format string (in quotes ' ' or " ").
4. Identify the dimension text to be changed.

Creo Elements/Direct Drafting changes the format of the dimension value.

5. Press **END** to end this command.

To change the number of decimal places in an existing primary dimension:

1. Pick **CHG LINES** from the **DIMENSION 3** screen menu.
2. Pick **CHG FORMAT**.
3. Pick **Main +** to add one decimal place or **Main -** to remove one decimal place.
4. Identify the dimension text to be changed.

Creo Elements/Direct Drafting changes the number of decimal places in the primary dimension value.

5. Press **END** to end this command.

To change the number of decimal places in an existing secondary dimension:

1. Pick **CHG LINES** from the **DIMENSION 3** screen menu.
2. Pick **CHG FORMAT**.
3. Pick **Sec +** to add one decimal place or **Sec -** to remove one decimal place.
4. Identify the dimension text to be changed.

Creo Elements/Direct Drafting changes the number of decimal places in the secondary dimension value.

5. Press **END** to end this command.

Changing Dimension Color

This section shows how to change the color of the extension lines and dimension lines.

To change a dimension color:

1. Pick **CHG LINES** from the **DIMENSION 3** screen menu.
2. Pick **CHG COLOR**.
3. Enter a color name at the command prompt.
4. Identify the dimension text of the dimension geometry to be changed.

Creo Elements/Direct Drafting changes the color of the dimension geometry.

5. Press **END** to end this command.

Changing Terminators

This section shows how to change the type, size, and fill settings of a dimension line terminator. An arrowhead is the default terminator.

Figure 142. Dimension Line Terminators on page 270 shows the five dimension line terminators.

Figure 142. Dimension Line Terminators

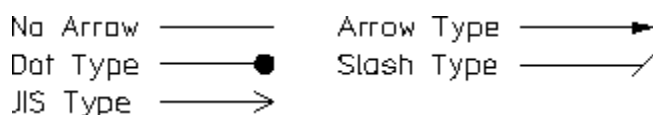

To change the dimension line terminator:

1. Pick **CHG LINES** from the **DIMENSION 3** screen menu.
2. Pick **CHG ARROW** and either Both, First, or Second.
3. Pick the new settings for the terminator in **OPTIONS**.

4. Identify the dimension text for the terminator.

Creo Elements/Direct Drafting changes the attributes for the terminator.

5. Press **END** to end this command.

You can change either the first, the second or both terminators using the CHG ARROW options:

Both	This is the default option. The terminator settings you select will apply to both of the dimension line terminators.
First	This refers to the first element you identified when the dimension was specified.
Second	This refers to the second element you identified when the dimension was specified.

Selecting Terminator Attributes

After selecting the required dimension line terminator to change, select new attributes for that terminator from OPTIONS:

- Fill On
- Size Rel
- Fill Off
- Size Abs
- No Arrow
- Arrow Type
- Dot Type
- Slash Type
- JIS Type
- Inside
- Outside
- Auto

Filling Terminators

Use this attribute option to fill the arrowhead and dot type terminators.

To fill a terminator:

1. Pick **CHG LINES** from the **DIMENSION 3** screen menu.
2. Pick **CHG ARROW** and either **Both**, **First**, or **Second**.
3. Pick **Fill On** in **OPTIONS**.

-
4. Identify the dimension text with an arrowhead or dot type terminator.

Turning Filling Off

To turn filling off in an arrowhead or dot type terminator:

1. Pick **CHG LINES** from the **DIMENSION 3** screen menu.
2. Pick **CHG ARROW** and either **Both**, **First**, or **Second**.
3. Pick **Fill Off** in **OPTIONS**.
4. Identify the dimension text with an arrowhead or dot type terminator.

Terminator — Relative Size

You can change the size of the dimension line terminator by a scale factor. This factor is relative to the current dimension text size.

To change the relative size of the terminator:

1. Pick **CHG LINES** from the **DIMENSION 3** screen menu.
2. Pick **CHG ARROW** and either **Both**, **First**, or **Second**.
3. Pick **Size Rel** in **OPTIONS**.
4. Enter a scale factor.
5. Identify the dimension text with the terminator to be changed.

Terminator — Size Absolute

To change the absolute size of the dimension line terminator:

1. Pick **CHG LINES** from the **DIMENSION 3** screen menu.
2. Pick **CHG ARROW** and either **Both**, **First**, or **Second**.
3. Pick **Size Abs** in **OPTIONS**.
4. Enter a size.
5. Identify the dimension text with the terminator to be changed.

Removing the Terminator

To remove the dimension terminator:

1. Pick **CHG LINES** from the **DIMENSION 3** screen menu.
2. Pick **CHG ARROW** and either **Both**, **First**, or **Second**.
3. Pick **No Arrow** in **OPTIONS**.
4. Identify the dimension text with the terminator to be removed.

Selecting a Terminator type

You can select one of four terminator types:

1. Pick **CHG LINES** from the **DIMENSION 3** screen menu.
2. Pick **CHG ARROW** and either Both, First, or Second.
3. Pick either **Arrow Type**, **Dot Type**, **Slash Type** or **JIS Type** in **OPTIONS**.
4. Identify the dimension text to have that terminator.

The option First refers to the first element that is identified, and Second to the second element identified.

Example

To change the filled arrowhead terminator to the right (this is the second element that was identified) of the dimension text to a filled dot type terminator:

Figure 143. Dimension with Arrow Terminators

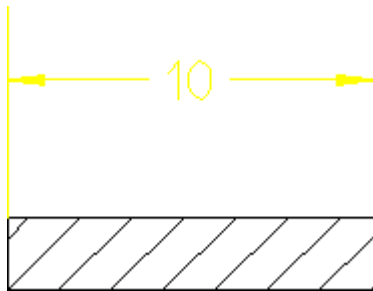

1. Pick **CHG LINES** from the **DIMENSION 3** screen menu.
2. Pick **CHG ARROW** and Second.
3. Pick **Fill On** in **OPTIONS**.
4. Pick **Dot Type** in **OPTIONS**.
5. Identify the dimension text for the terminator.

Figure 144. [Arrow and Filled Dot Terminators on page 273](#) shows the arrow and filled dot terminators.

Figure 144. Arrow and Filled Dot Terminators

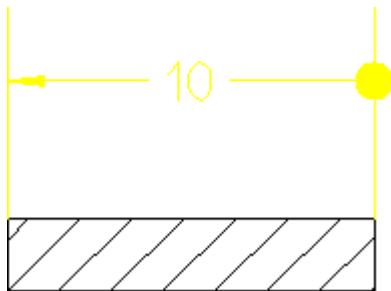

Changing Terminator Position

By default, the position of terminators with respect to the extension lines is determined automatically. If there is enough room between the dimension's extension lines for the terminators and dimension text, the terminators are placed between the extension lines. Otherwise, terminators are placed outside of the extension lines. The terminator position can also be set manually.

To change the current terminator position:

1. Pick **CHG LINES** from the **DIMENSION 3** screen menu.
2. Pick **CHG ARROW**.
3. Select **Inside**, **Outside**, or **Auto** in **OPTIONS**.
4. Identify the dimensions to be changed.



Note

You cannot change the terminator position for [Broken on page 243](#) dimension lines.

Changing the Dimension-Line Pensize

1. Pick **CHG LINES** from the **DIMENSION 3** screen menu.
2. Pick **CHG PENSIZ**.
3. Enter a value.
4. Identify the dimensions to be changed.

Setting the Offset Point

Various national standards are used for dimensioning (American Standards, British Standards, and so on). You can set the distance (or offset) between the geometry feature and the dimension extension lines to conform to the standards you use. The Creo Elements/Direct Drafting default for this distance is 0 mm.

To set the dimension offset point distance:

1. Press **DIMENSION 3** and pick the **SET LINES** menu.
2. Pick **OFFSET PNT**.
3. Enter any positive value for the distance.

Creo Elements/Direct Drafting sets this offset distance for all subsequent dimensions.

Example

To set the distance between a geometry feature and the dimension extension lines to 1.5 mm:

1. Press **DIMENSION 3** and pick the **SET LINES** menu.
2. Pick **OFFSET PNT**.
3. Enter 1.5.

Creo Elements/Direct Drafting sets the offset distance to 1.5 mm for all subsequent dimensions.

Figure 145. Dimension Offset Point on page 275 shows the dimension offset point.

Figure 145. Dimension Offset Point

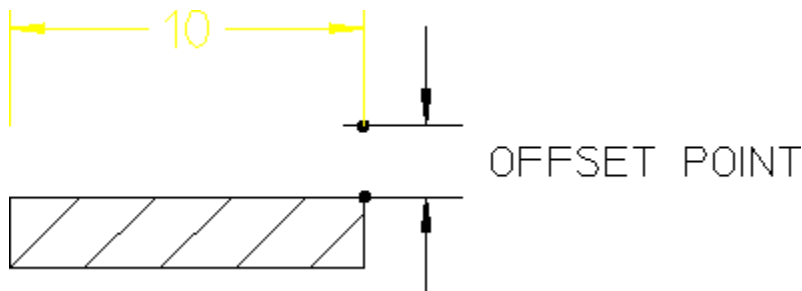

Setting Dimension Offset

Various national standards are used for dimensioning (American Standards, British Standards, and so on). You can set the distance (or offset) between the top end of the extension line and the dimension line to conform to the standards you use. The Creo Elements/Direct Drafting default for this distance is 2 mm.

To set the dimension offset:

1. Press **DIMENSION 3** and pick the **SET LINES** menu.
2. Pick **OFFSET LIN**.
3. Enter a positive value for the distance.

Creo Elements/Direct Drafting sets this distance for all subsequent dimensions.

Example

To set the distance between the top end of the extension line and the dimension line to 3 mm:

1. Press **DIMENSION 3** and pick the **SET LINES** menu.

2. Pick **OFFSET LIN**.
3. Enter 3.

Creo Elements/Direct Drafting sets the offset distance to 3 mm for all subsequent dimensions.

Figure 146. Dimension Offset Line Distance on page 276 shows the dimension offset line distance.

Figure 146. Dimension Offset Line Distance

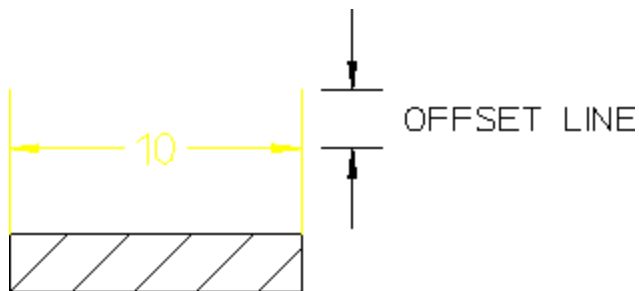

Changing Text Attributes

CHG TEXTS gives you access to the commands that change attributes of existing dimension text items in your drawing.

The commands available under CHG TEXTS are:

CHG TEXT	Changes text appearance attributes such as size, font, slant, and aspect ratio.
CHG UNITS	Changes the units used for the upper and/or lower dimensioning text.
CHG FRAME	Changes the type of box drawn around selected dimensioning text.
CHG DIMLOC	Changes the location of the dimension text.
CHG ORIENT	Changes the orientation of the dimension text.
CHG TOLERA	Edits, adds, deletes, or converts tolerance entities on selected dimensioning text.
CHG PREFIX	Edits, adds, or deletes prefix information on selected dimensioning text.
CHG POSTFX	Edits, adds, or deletes postfix information on selected dimensioning text.
EDIT TEXT	Edits dimensioning text.
CANC EDIT	Cancels any editing you may have performed on a selected dimension text entity.

Dimension text consists of several components:

- Prefix
- Dimension value
- Tolerance
- Postfix

You can change the appearance of any of the dimension text components. To change the appearance of dimension text:

1. Pick CHG TEXTS from the **DIMENSION 3** screen menu.
2. Pick CHG TEXT and the component of the dimension text.
3. Pick the new attribute from the OPTIONS list.
4. Identify the dimension text to change.
5. Press **END** to end this command.

You can change the appearance of dimension text using CHG TEXT options:

- All
- Lower
- Upper
- Lower Val
- Upper Val
- Lower Tol
- Upper Tol
- Prefix
- Postfix

All Text

Pick **All** to select all dimension text including postfix, prefix, and tolerance.

Lower Text

Pick **Lower** to select the lower dimension text only.

Upper Text

Pick **Upper** to select the upper dimension text only.

Lower Value

Pick **Lower Val** to select the lower dimension value only.

Upper Value

Pick **Upper Val** to select the upper dimension value only.

Lower Tolerance

Pick **Lower Tol** to select the lower tolerance value only.

Upper Tolerance

Pick **Upper Tol** to select the upper tolerance only.

Prefix Text

Pick **Prefix** to select the prefix text only.

Postfix Text

Pick **Postfix** to select the postfix text only.

Selecting Text Attributes

When you have chosen the components of the dimension text you want to change, you can select attribute(s) for the text from OPTIONS:

- Size Abs
- Font
- Size Rel
- Slant
- Ratio
- Fill
- Brackets (only visible after Lower or Upper)
- **COLOR**

Absolute Text Size

This is the default option.

To change the absolute size of selected dimension text:

-
1. Pick **CHG TEXTS** from the **DIMENSION 3** screen menu.
 2. Pick **CHG TEXT** and select the dimension text component to change.
 3. Pick **Size Abs** in **OPTIONS**.
 4. Enter a new text size.
 5. Identify the dimension text you want to change.

Text Font

The default font is `osd_default`. For a list of font names, refer to [Adding Text to a Drawing on page 322](#).

To change the dimension text font:

1. Pick **CHG TEXTS** from the **DIMENSION 3** screen menu.
2. Pick **CHG TEXT** and select the dimension text component to change.
3. Pick **Font** in **OPTIONS**.
4. Enter a font name (in quotes ' ' or " ").
5. Identify the dimension text for the new font.

Relative Text Size

You can change the size of the selected text relative to the main dimension text size. Creo Elements/Direct Drafting multiplies the relative factor by the current main dimension text size to give a new text size for the selected dimension text.

To change the relative text size:

1. Pick **CHG TEXTS** from the **DIMENSION 3** screen menu.
2. Pick **CHG TEXT** and select the dimension text component to change.
3. Pick **Size Rel** in **OPTIONS**.
4. Enter a relative factor for the text size.
5. Identify the dimension text to change size.

Text Slant

The Creo Elements/Direct Drafting default text slant is 0 degrees.

To change dimension text slant:

1. Pick **CHG TEXTS** from the **DIMENSION 3** screen menu.
2. Pick **CHG TEXT** and select the dimension text component to change.
3. Pick **Slant** in **OPTIONS**.

-
4. Enter a new slant angle.
 5. Identify the dimension text you want to change.

Text Ratio

You can change the width-to-height ratio for all characters in the dimension text you selected. The Creo Elements/Direct Drafting default is 1. A number less than one produces thin characters, a number greater than one produces thick characters.

To change the character ratio:

1. Pick **CHG TEXTS** from the **DIMENSION 3** screen menu.
2. Pick **CHG TEXT** and select the dimension text component to change.
3. Pick **Ratio** in **OPTIONS**.
4. Enter a new width-to-height ratio.
5. Identify the dimension text you want to change.

Creo Elements/Direct Drafting displays the identified dimension text with the new ratio.

Example

This example shows how to:

- Change the postfix text to have a slant of 30 degrees.
- Change all the dimension text to an absolute size of 10 mm.

To make these changes, complete the following procedure:

1. Pick **CHG TEXTS** from the **DIMENSION 3** screen menu.
2. Pick **CHG TEXT** and **Postfix**.
3. Pick **Slant** in **OPTIONS**, then enter 30.
4. Identify the dimension text to be changed.
5. Pick **All** in **CHG TEXT**.
6. Pick **Size Abs** in **OPTIONS**, then enter 10.
7. Identify the dimension text to be changed.

Brackets

Dimension text can be enclosed in brackets [] or not.

To toggle brackets on or off:

1. Pick **CHG TEXTS** from the **DIMENSION 3** screen menu.
2. Pick **CHG TEXT** and either **Lower** or **Upper**.

3. Pick **Brackets** in **OPTIONS**.

4. Enter ON or OFF.

The style display window is updated if needed to show any change in text appearance.

Changing Units

This section shows how to change the existing units used for the upper or lower dimension text to any of the units in the **OPTIONS** list.

To change the dimension units:

1. Pick **CHG TEXTS** from the **DIMENSION 3** screen menu.
2. Pick **CHG UNITS** and either **Upper Dim** or **Lower Dim**.
3. Pick the new units from the **OPTIONS** list.
4. Identify the dimension text you want to change.
5. Press **END** to end this command.

The **CHG UNITS** options are:

- Upper Dim
- Lower Dim

The unit options are:

- mm
- cm
- Meters
- km
- Degree
- Radian
- Dg Min Sec
- Inches
- Frct inch
- Ft fr inch
- Ft fr in s
- Ft fr in t
- None

Example

The example below shows how to change dimension units from millimeters to fractional inches.

Figure 147. Changing Millimeters to Fractional Inches on page 282 shows the dimension before and after the change:

Figure 147. Changing Millimeters to Fractional Inches



To change a dimension from millimeters to fractional inches:

1. Pick **CHG TEXTS** from the **DIMENSION 3** screen menu.
2. Pick **CHG UNITS** and Upper Dim.
3. Pick **Frct inch** in **OPTIONS**.
4. Identify the dimension text you want to change.

Upper Dimension

This is the default option. Pick **Upper Dim** to change the units of the main (or upper) dimension text.

Lower Dimension

Pick **Lower Dim** to change the units of the lower dimension text (if the text is present).

Choosing Units

After picking the **Upper Dim** or **Lower Dim**, simply select the new units for that text.

The units available are:

um

Pick um to change the dimension units to micrometers.

mm

This is the default option. Pick mm to change the dimension units to millimeters.

CM

Pick cm to change the dimension units to centimeters.

Meters

Pick **Meters** to change the dimension units to meters.

km

Pick **km** to change the dimension units to kilometers.

Inch

Pick **Inch** to change the dimension units to inches.

Frct inch (Fractional Inches)

Pick **Frct inch** to change the dimension units to fractional inches. For example, 1" and 6 1/2".

Ft fr inch (Feet and Fractional Inches)

Pick **Ft fr inch** to change the dimension units to feet and fractional inches. For example, 1 - 0 and 0 - 6 1/2.

Ft fr in s (Feet and Fractional Inches with Sign)

Pick **Ft fr in s** to change the dimension units to feet and fractional inches. Creo Elements/Direct Drafting displays the dimension values with feet and inches indicated by a sign. For example, 1' - 0", and 0' - 6 1/2".

Ft fr in t (Feet and Fractional Inches with Text)

Pick **Ft fr in t** to change the dimension units to feet and fractional inches. Creo Elements/Direct Drafting displays the dimension value with feet and inches indicated by text. For example, 1 FT 0 IN, and 0 FT 6 1/2 IN.

Degree

Pick **Degree** to change the angle dimension units to degrees.

Radian

Pick **Radian** to change the angle dimension units to radians.

Dg Min Sec (Degrees Minutes Seconds)

Pick **Dg Min Sec** to change the angle dimension units to degrees, minutes, and seconds.

None

To switch off dual dimensioning:

1. Pick **CHG TEXTS** from the **DIMENSION 3** screen menu.

2. Pick **CHG UNITS** and **Lower Dim.**
3. Pick **None** in **OPTIONS**.
4. Identify the dimension text you want to change.

Changing the Dimension Text Frame

This section shows how to change the frame around any existing dimension text.

A dimension's text has a frame around it. The frame is normally switched off. However you can switch it on using the **CHG FRAME** command. You can make the frame appear as a balloon shaped frame or a box shaped frame or a flag shaped frame or a basic frame.

The **CHG FRAME** options are:

- Off
- Balloon
- Box
- Flag
- Basic

To change the frame around any existing dimension text:

1. Pick **CHG TEXTS** from the **DIMENSION 3** screen menu.
2. Pick **CHG FRAME** and **Off**, **Balloon**, **Box** or **Flag**.
3. Identify the dimension text you want to change.
4. Press **END** to end this command.

Figure 148. [Frame Options on page 284](#) shows the four **CHG FRAME** options.

Figure 148. Frame Options



Changing a Dimension's Location and Orientation

To change the location of dimension text:

1. Pick **CHG DIMLOC** in **CHG TEXTS (DIMENSION 3 menu)**.
2. Pick one of the following:
 - On Line
 - Above Line
 - Below Line

-
3. Pick the dimension.

To change the orientation of dimension text:

1. Pick **CHG ORIENT** in **CHG TEXTS (DIMENSION 3)** menu)
2. Pick one of the following in **CHG ORIENT**:
 - Parallel
 - Horizontal
 - Vertical
 - Perpend
3. Pick the dimension to be changed.

Changing a Dimension Tolerance

This section shows how to:

- Edit an existing tolerance value.
- Add a tolerance to an existing dimension.
- Delete a tolerance from a dimension.
- Convert an existing tolerance type into another tolerance type.

To change a dimension tolerance:

1. Pick **CHG TEXTS** from the **DIMENSION 3** screen menu.
2. Pick **CHG TOLERA** and **Edit**, **Add**, **Delete**, or **Convert**.
3. Pick a tolerance type from the **OPTIONS** list.
4. Press **END** to end this command.

The CHG TOLERA options are:

- Edit
- Add
- Delete
- Convert

Editing a Tolerance

To edit a tolerance:

1. Pick **CHG TEXTS** from the **DIMENSION 3** screen menu.
2. Pick **CHG TOLERA** and **Edit**.
3. Identify the text containing the tolerance that you want to edit.

Creo Elements/Direct Drafting displays the tolerance text in the User Input Line.

4. Edit the tolerance text.
5. Press [Enter].

Creo Elements/Direct Drafting displays the new tolerance in the dimension text.

Adding a Tolerance

To add a tolerance to a dimension:

1. Pick **CHG TEXTS** from the **DIMENSION 3** screen menu.
2. Pick **CHG TOLERA** and **Add**.
3. Pick the type of tolerance you want to add in **OPTIONS**.
4. Enter the necessary tolerance information.
5. Identify the dimension text to which the tolerance applies.

Creo Elements/Direct Drafting adds the new tolerance to the dimension text.

Deleting a Tolerance

Pick Delete to delete a tolerance.

To delete a tolerance:

1. Pick **CHG TEXTS** from the **DIMENSION 3** screen menu.
2. Pick **CHG TOLERA** and **Delete**.
3. Identify the tolerance that you want to delete.

Creo Elements/Direct Drafting deletes the tolerance.

Converting a Tolerance

To convert a tolerance:

1. Pick **CHG TEXTS** from the **DIMENSION 3** screen menu.
2. Pick **CHG TOLERA** and **Convert**.
3. Pick the new tolerance type in **OPTIONS**.
4. Identify the dimension text to be changed.

Tolerance Types

When you have selected add or convert, you need to specify the new tolerance type you want to add or convert to.

The types of tolerances are:

- Limit (limit tolerancing)
- Plus/Minus (plus and minus tolerancing)
- Upper/Lower (upper and lower tolerancing)

To be able to convert a tolerance into a new tolerance type, Creo Elements/Direct Drafting needs the complete tolerance information for the new tolerance type. For example, if you want to convert upper and lower tolerancing to plus and minus tolerancing, the upper and lower tolerances must be equal in value, and the lower tolerance must be negative.

Limit Tolerances

When adding or converting to limit tolerancing, Creo Elements/Direct Drafting assumes that both upper and lower values are positive. If you require either value to be negative you must start the value with a negative sign (—).

Figure 149. Limit Tolerancing on page 287 shows an example of limit tolerancing.

Figure 149. Limit Tolerancing

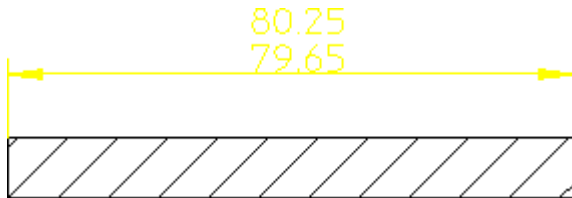

To add a limit tolerance to a dimension:

1. Pick **CHG TEXTS** from the **DIMENSION 3** screen menu.
2. Pick **CHG TOLERA** and **Add**.
3. Pick **Limit** in **OPTIONS**.
4. Enter the upper limit tolerance value.
5. Enter the lower limit tolerance value.

Plus/Minus Tolerancing

Pick Plus/Minus to add, or convert to, plus and minus tolerancing.

Figure 150. Plus and Minus Tolerancing on page 288 shows an example of plus and minus tolerancing.

Figure 150. Plus and Minus Tolerancing

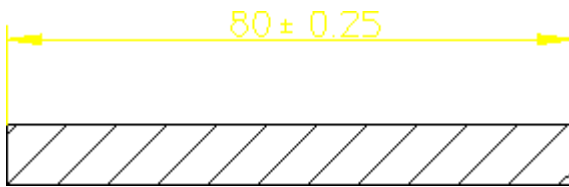

To add a plus/minus tolerance:

1. Pick **CHG TEXTS** from the **DIMENSION 3** screen menu.
2. Pick **CHG TOLERA** and **Add**.
3. Pick **Plus/Minus** in **OPTIONS**.
4. Enter the plus and minus tolerance value.

Upper/Lower Tolerancing

When adding or converting to upper and lower tolerancing, Creo Elements/Direct Drafting assumes that both upper and lower values are positive. If you require either value to be negative you must start the value with a negative sign (-).

[Figure 151. Upper and Lower Tolerancing on page 288](#) shows an example of upper and lower tolerancing.

Figure 151. Upper and Lower Tolerancing

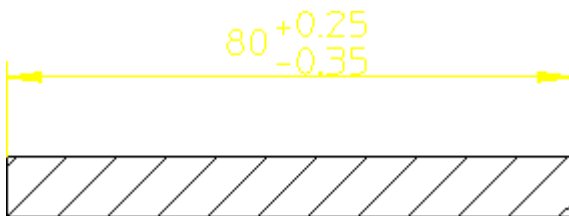

To add an upper/lower tolerance to a dimension:

1. Pick **CHG TEXTS** from the **DIMENSION 3** screen menu.
2. Pick **CHG TOLERA** and **Add**.
3. Pick **Upper/Lower** in **OPTIONS**.
4. Enter the upper tolerance value.
5. Enter the lower tolerance value.

Changing a Dimension Prefix

This section shows how to:

- Edit an existing dimension prefix.
- Add a prefix to an existing dimension.

-
- Delete a prefix from a dimension.

You can add, edit, or delete both, the basic and normal prefix text.

To change a dimension prefix:

1. Pick **CHG TEXTS** from the **DIMENSION 3** screen menu.
2. Pick **CHG PREFIX** and **Edit**, **Add**, or **Delete**.
3. Complete the option sequence.
4. Press **END** to end this command.

The **CHG PREFIX** options are:

- Edit
- BASIC_DIM
- Add
- Delete

Editing a Prefix

To change an existing prefix:

1. Pick **CHG TEXTS** from the **DIMENSION 3** screen menu.
2. Pick **CHG PREFIX** and **Edit**.
3. Pick **BASIC_DIM** for the basic dimension prefix.
4. Identify the dimension text containing the prefix you want to edit.
Creo Elements/Direct Drafting displays the prefix in the User Input Line.
5. Edit the text (in quotes ' ' or " ").
6. Press [Enter].
Creo Elements/Direct Drafting displays the new prefix.

Adding a Prefix

To add a prefix to a dimension:

1. Pick **CHG TEXTS** from the **DIMENSION 3** screen menu.
2. Pick **CHG PREFIX** and **Add**.
3. Pick **BASIC_DIM** for the basic dimension prefix.
4. Enter the prefix (in quotes ' ' or " ").
5. Identify the dimension text to be prefixed.
Creo Elements/Direct Drafting adds the new prefix to the dimension.

Deleting a Prefix

To delete a prefix:

1. Pick **CHG TEXTS** from the **DIMENSION 3** screen menu.
2. Pick **CHG PREFIX** and **Delete**.
3. Pick **BASIC_DIM** for the basic dimension prefix.
4. Identify the prefix you want to delete.

Creo Elements/Direct Drafting deletes the prefix.

Changing a Dimension Postfix

You can add, edit, or delete both, the basic and normal postfix text.

This section shows how to:

- Edit an existing postfix.
- Add a postfix to an existing dimension.
- Delete a postfix from a dimension.

To change a postfix:

1. Pick **CHG TEXTS** from the **DIMENSION 3** screen menu.
2. Pick **CHG POSTFX** and **Edit**, **Add**, **BASIC_DIM** or **Delete**.
3. Complete the option sequence.
4. Press **END** to end this command.

The **CHG POSTFX** options are:

- Edit
- BASIC_DIM
- Add
- Delete

Editing a Postfix

To edit an existing postfix:

1. Pick **CHG TEXTS** from the **DIMENSION 3** screen menu.
2. Pick **Edit** in **CHG POSTFX**.
3. Pick **BASIC_DIM** for the basic dimension postfix.
4. Identify the dimension text containing the postfix you want to edit.

Creo Elements/Direct Drafting displays the postfix in the User Input Line.

-
5. Edit the text (in quotes ' ' or " ").
 6. Press [Enter].

Creo Elements/Direct Drafting displays the new postfix.

Adding a Postfix

To add a postfix to a dimension:

1. Pick **CHG TEXTS** from the **DIMENSION 3** screen menu.
2. Pick **CHG POSTFX** and **Add**.
3. Pick **BASIC_DIM** for the basic dimension postfix.
4. Enter the postfix (in quotes ' ' or " ").
5. Identify the dimension text to be postfixed.

Creo Elements/Direct Drafting adds the new postfix to the dimension.

Deleting a Postfix

To delete a postfix:

1. Pick **CHG TEXTS** from the **DIMENSION 3** screen menu.
2. Pick **CHG POSTFX** and **Delete**.
3. Pick **BASIC_DIM** for the basic dimension postfix.
4. Identify the postfix you want to delete.

Creo Elements/Direct Drafting deletes the postfix.

Editing Text

This section shows how to edit existing dimension text. Identified dimension text is displayed in the User Input Line. After editing the text, make sure that quotes (' ' or " ") surround the text, then press [Enter].

Creo Elements/Direct Drafting will redraw the edited dimension text.

To edit existing dimension text:

1. Pick **CHG TEXTS** from the **DIMENSION 3** screen menu.
2. Pick **EDIT TEXT**.
3. Identify the dimension text to edit.

Creo Elements/Direct Drafting displays the dimension text in the User Input Line.

4. Edit the text, then press [Enter].
5. Press **END** to end this command.

Dimension Underlining

Creo Elements/Direct Drafting provides the possibility to underline dimension text. This is particularly useful when you want to flag a dimension that has been manually changed (or edited). This underlining feature is a requirement of DIN dimensioning standards. The default setting depends on the selected dimension standard:

DIN Standard	Default is on.
ANSI, ISO, JIS, or COMPANY Standard	Default is off.

If the selected dimension standard is DIN, dimension text that is edited is automatically underlined. Otherwise, edited dimension text is not underlined but can be underlined selectively. Dimension underlines have the following properties:

- The length is the same length as the dimension text.
- Prefixes, postfixes, and tolerances are not underlined.
- The color is the same as dimension lines.
- The space between the dimension text and underline is fixed.
- The pensize is the same as that of the dimension lines.

To underline a dimension:

1. Pick **EDIT TEXT** in **CHG TEXTS (DIMENSION 3)** menu)
2. Switch **UNDERLINE** to **On** (toggle action)
3. Pick the dimension to be underlined
4. Press [Enter] to accept the current value (you can change this value if you wish)
5. Creo Elements/Direct Drafting displays the edited dimension value with an underline.

Figure 152. Dimension Underlining

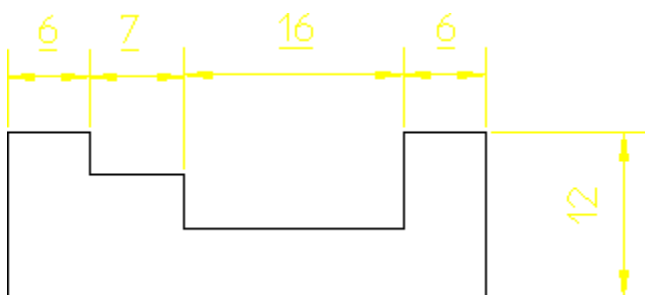

To remove an underline:

1. Pick **CANC EDIT** in **CHG TEXTS (DIMENSION 3)** menu)

-
2. Pick the underlined dimension you want to reset
 3. Creo Elements/Direct Drafting resets the value to the original value and the underline is deleted.

Canceling a Dimension Text Edit

This section shows how to cancel an edit and display the dimension text in its original form. This means that if you edit the dimension text twice and then use **CANC EDIT**, the original dimension text will appear and not your first edited version of the text.

To cancel an edit:

1. Pick **CHG TEXTS** from the **DIMENSION 3** screen menu.
2. Pick **CANC EDIT**.
3. Identify the dimension text you want to reset to its original version.
Creo Elements/Direct Drafting displays the original dimension text.
4. Press **END** to end this command.

Setting Dimension Attributes with the STYLE Table

The **STYLE** table, [Figure 153. STYLE Table, with a sample entry on page 294](#), allows you to store your current dimensioning style settings (font, size, units, line styles, etc.) as table entries. You can later recover the stored style settings and make them the current dimensioning style simply by selecting the table entry. The currently active settings are always previewed in the style display window, so you always know what you will be assigning.

If you often dimension particular features or details in a given style, the **STYLE** table frees you from having to manually set up that style each time you need it.

Figure 153. STYLE Table, with a sample entry

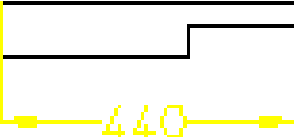
DIMENSION 1		
Standard	COMPANY	
Filter	On	
SINGLE	SYN SINGLE	
DATUM LONG	SYN LONG	
DATUM SHRT	CHAIN	
COORDINATE	CHAMFER	
RADIUS	DIAMETER	
ARC	ANGLE	
GEO SENS	SCAN	
MANUAL	Parallel	
Horizontal	Vertical	
Perpend to	Parall to	
Prefix	Postfix	Tolera
Suprfix	Subfix	STYLE
		
MENU 2	MENU 3	

STYLE			
ADD	DELETE	STORE	LOAD
CLEAR	GRAB	APPLY	EDIT
DIM Txt Size 15			
DIM Txt Size 20			

Adding a Table Entry

Before you can take advantage of the STYLE table, you need to add one or more entries to hold the style settings you want to apply later. To create an entry in this table:

1. Set up the dimensioning style that you want to save to the table. You can use the SET LINES and SET TEXTS options on **DIMENSION 3** to do this. The style display window shows the current settings.
2. Press **DIMENSION 1** and pick **STYLE**.
3. Pick **ADD**.

-
4. Enter a name for the new table entry at the command prompt.
Creo Elements/Direct Drafting adds the new entry to the table.

Setting the Current Dimension Style with the STYLE Table

1. Press **DIMENSION 1** and pick **STYLE**.
2. Pick an entry from the table.

Creo Elements/Direct Drafting makes the dimensioning style settings associated with this entry into the current settings. These settings will be used for subsequent dimensioning.

The style display window is updated to reflect the new settings.

Assigning Dimension Styles with the STYLE Table

You can assign a new dimensioning style to an existing dimension with the **APPLY** option of the **STYLE** table:

1. Set up the desired dimensioning style, using either the **SET** commands on **DIMENSION 3** or the **STYLE** table.
2. Press **DIMENSION 1** and pick **STYLE**.

The style display window should reflect the settings you want to apply.

3. Pick **APPLY**
4. Select dimensions in your drawing to receive the new settings.

Creo Elements/Direct Drafting updates the style of the selected dimensions to match the current style.

Setting the Current Dimension Style from An Existing Dimension

The **GRAB** command queries the style settings of a selected dimension and then makes them the current settings. You can use these settings for new dimensions or store them as an entry in the **STYLE** table.

1. Press **DIMENSION 1** and pick **STYLE**.
2. Pick **GRAB**
3. Select the text of a dimension in your drawing.

Creo Elements/Direct Drafting makes the style settings of the selected dimension the current settings.

-
4. Press **END**.

Editing a Table Entry

Each entry in the STYLE table is a macro that contains the dimension style commands needed to define the entry's style. The entry can be modified by editing this macro.

1. Press **DIMENSION 1** and pick **STYLE**.
2. Pick **EDIT** and select the table entry you wish to change.
Creo Elements/Direct Drafting displays the entry's macro in a screen editor window.
3. Edit the text, then press [Ctrl] [D].

Deleting an Entry

1. Press **DIMENSION 1** and pick **STYLE**.
2. Pick the **DELETE** option.
3. Pick the table entry to delete.

Clearing a Style

The **CLEAR** command clears the dimension of all attributes, for example, prefixes, postfixes, and tolerances.

1. Press **DIMENSION 1** and pick **STYLE**.
2. Pick the **CLEAR** option.

Saving the STYLE Table to a File

The STYLE table can be stored in a file for use at a later time.

1. Press **DIMENSION 1** and pick **STYLE**.
2. Pick **STORE** and supply a filename at the command prompt.
Creo Elements/Direct Drafting stores the table macros in the given file.

Loading Table Entries from a File

New table entries can be appended to the STYLE table by loading them from a file.

1. Press **DIMENSION 1** and pick **STYLE**.

-
2. Pick **LOAD** and supply a filename at the command prompt.

Creo Elements/Direct Drafting loads the table macros from the given file into the STYLE table. These entries are appended to the end of the table.

Modifying Dimensions

The following sections describe how to modify the layout of existing dimensions. Modification commands and functions are provided in the DIMENSION 2 menu.

Modifying Dimension Text

This section shows how to move or rotate existing dimension text, with or without the associated dimension lines.

To move or rotate dimension text:

1. Pick **MODIFY** from the **DIMENSION 2** screen menu.
2. Pick an option in **MOD TEXT**.
3. Complete the option sequence.
4. Press **END** to end this command.

The **MOD TEXT** options are:

- Mv Txt&Lin
- RotateText
- Move Text

Moving Complete Dimensions

To move one or more complete dimensions:

1. Pick **MODIFY** from the **DIMENSION 2** screen menu.
2. Pick **Mv Txt&Lin**.
3. Identify the dimension text of the dimension(s) you want to move.
Creo Elements/Direct Drafting draws a trace of the dimensions.
4. Indicate the desired location for the dimension text.

Creo Elements/Direct Drafting relocates the selected dimensions.

Moving Dimension Text and Leader Line

To move a dimension text and its associated leader line:

1. Pick **Txt&Leader** from the **DIMENSION 2** menu.

2. Identify the dimension whose text and leader lines you want to move. Creo Elements/Direct Drafting draws a trace of the dimension text and its leader line.
3. Indicate the desired location for the dimension text. Creo Elements/Direct Drafting relocates the selected dimension text and its leader line.

Figure 154. Moving a Dimension Text and Its Leader Line

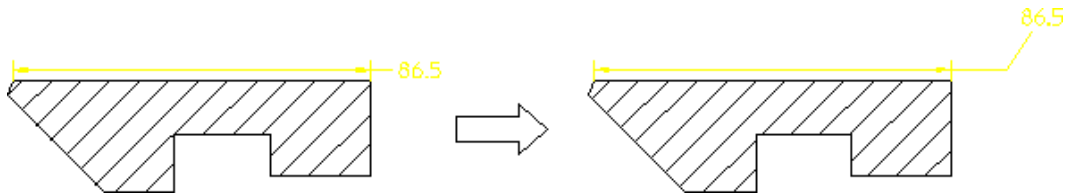

Rotating Dimension Text

Horizontal is the zero angle and positive rotation is counterclockwise.

To rotate dimension text:

1. Pick **MODIFY** from the **DIMENSION 2** screen menu.
2. Pick **RotateText** in **MOD TEXT**.
3. Enter an absolute angle of rotation.
4. Identify the dimension text(s) you want to rotate.

Creo Elements/Direct Drafting rotates the selected dimension text.

Moving Dimension Text

To move dimension text without moving the dimension or extension lines:

1. Pick **MODIFY** from the **DIMENSION 2** screen menu.
2. Pick **Move Text** in **MOD TEXT**.
3. Identify the dimension text items you want to move.

Creo Elements/Direct Drafting replaces each selected dimension text item with a trace box.

4. Indicate the desired location for the dimension text.

Creo Elements/Direct Drafting relocates the selected dimension text items.

Replacing Moved Dimension Text

Dimension text that has been moved off the dimension line (but not rotated) can be restored to its original position on the line:

1. Pick **MODIFY** from the **DIMENSION 2** screen menu.

2. Pick **Move Text** in **MOD TEXT**.
3. Type `RESET` at the command prompt.
4. Identify the dimension text you want to move.

Creo Elements/Direct Drafting restores the dimension text to the dimension line.

Aligning Dimensions

Dimensions can be aligned other dimensions. First, you identify an existing dimension and align the new dimension above, below, or adjacent to it.

Figure 155. Aligning Dimensions to Other Dimensions

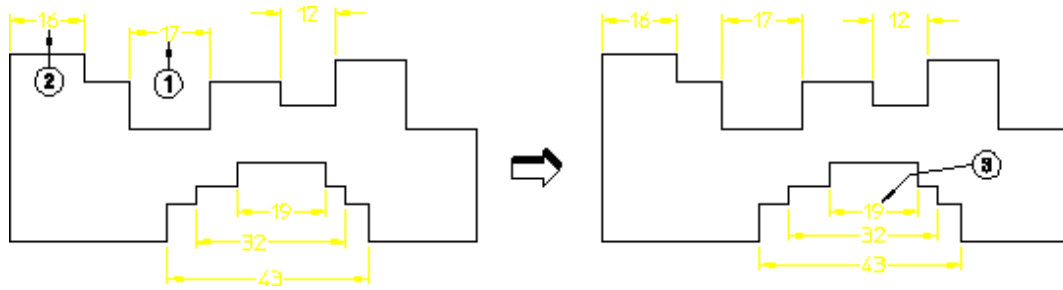

To align a dimension:

1. Click **MOD TEXT** in **DIMENSION 2**
2. Click the dimension to be aligned (point 1)
3. Click the reference dimension (point 2)
4. Drag the cursor to the new location (vicinity of point1)
5. Release the mouse button
6. Repeat for the lower dimensions (point 3)

Aligning of dimensions applies to single dimensions and not group dimensions (a group of dimensions cannot be boxed because each dimension needs a specific shift-vector). Additionally, aligning dimensions does not apply to non-linear dimensions such as:

- Diameters
- Radii
- Arcs

Inclining Dimensions

The dimension attributes Horizontal and Vertical can be overridden such that when an element is inclined, the dimension is also inclined. What you are doing is freezing the dimension to the describing element. This helps speed up the modification process for dimensioned geometry. Dimension attributes such as text size and font are not changed.

Figure 156. Effects of Freezing a Dimension

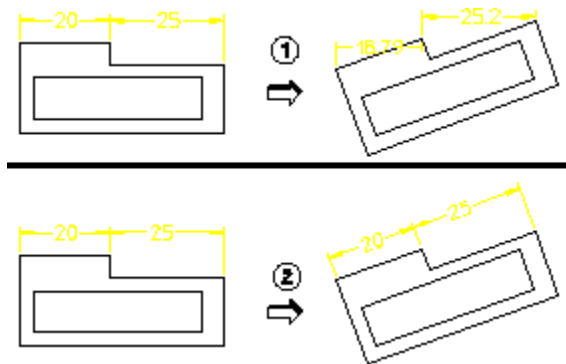

- 1 Dimension created by SINGLE, Horizontal. When the part is rotated 20°, the dimensions remain horizontal giving a correct but meaningless result.
- 2 Same as item 1 but the dimensions were frozen with FREEZE DIM before the part was modified.

To freeze a dimension:

1. Click **FREEZE DIM** in **DIMENSION 2**
2. Identify the dimension you want to incline

Note the following:

- If you use the select Box option when selecting dimensions, only those dimensions with the attribute Horizontal or Vertical are affected.
- There is no undo on this command.

Modifying Dimension and Extension Lines

If dimension and extension lines are crowded or overlapped, you can:

- Break an extension or dimension line.
- Stagger an extension line.
- Slant an extension line.
- Reset an extension or dimension line.

Any breaks, staggers and slants you make to a dimension line are retained until either:

- The dimension is reset with the Reset command.
- The location of the dimension is moved to within the range of the break or stagger.

To modify a dimension line:

1. Press **DIMENSION 2** and pick the **MODIFY DIM** menu.
2. Pick an option in **MOD LINES**.
3. Complete the option sequence.
4. Press **END** to end this command.

The **MOD LINES** options are:

- Break
- Reset
- Staggered
- Slant

Breaking Extension Lines

To break a dimension extension line around obstructing features:

1. Press **DIMENSION 1** and pick the **MODIFY DIM** menu.
2. Pick **Break** in **MOD LINES**.
3. Refer to [Figure 157. Broken Extension Line on page 301](#).

Figure 157. Broken Extension Line

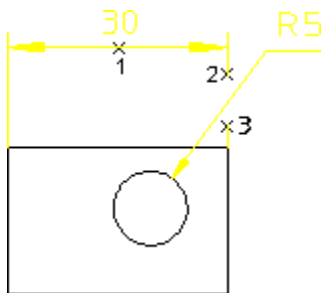

1. Identify the dimension text for the dimension (1).
2. Identify the start point for the break (2).
3. Identify the end point for the break (3).

Resetting Dimension Lines

To reset a broken, staggered, or slanted dimension line:

1. Press **DIMENSION 2** and pick the **MODIFY DIM** menu.
2. Pick **Reset** in **MOD LINES**.
3. Identify the dimension text for the dimension reset.

Staggering Extension Lines

To stagger dimension extension lines:

1. Press **DIMENSION 2** and pick the **MODIFY DIM** menu.
2. Pick **Staggered** in **MOD LINES**.
3. Refer to [Figure 158. Staggered Extension Lines on page 302](#).

Figure 158. Staggered Extension Lines

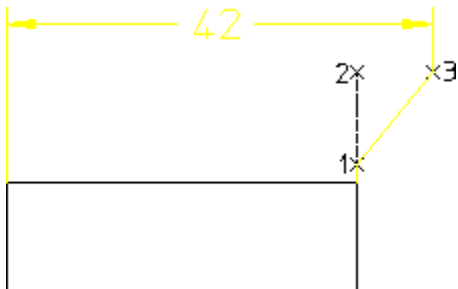

1. Identify the dimension text for the dimension.
2. Identify the start point for the stagger on the extension line (1).
3. Identify the end point for the stagger on the extension line (2).
4. Indicate the point where you want the stagger to go (3).

Figure 159. Effect of Moving Staggered Extension Lines

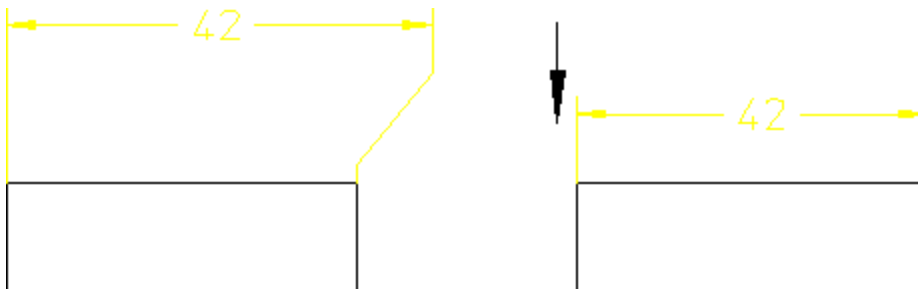

 **Note**

If a dimension contains several staggers, only the first is retained following a move.

Figure 160. Multiple Staggered Extension Lines

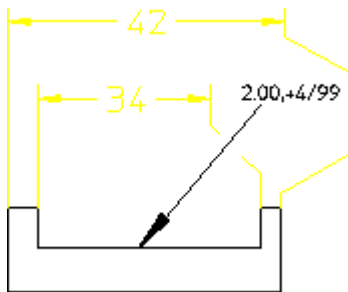

Slanting Extension Lines

To slant dimension extension lines:

1. Press **DIMENSION 1** and pick the **MODIFY DIM** menu.
2. Pick **Slant** in **MOD LINES**.
3. Refer to the following figure.

Slanted Extension Lines

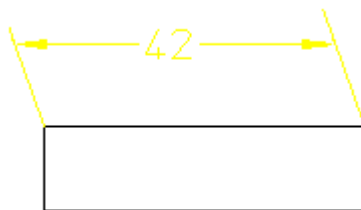

4. Type the slant angle in the **User Input Line**.
5. Select the dimension to slant.

The dimension extension lines are slanted by the specified angle.

 **Note**

Slant angles must be between 0 and 60 degrees, or 0 and -60 degrees. You can only slant the extension lines of single dimensions with a parallel dimension orientation. Broken or staggered dimensions can be slanted and slanted dimensions can be broken or staggered. A slanted dimension cannot be further slanted.

Modifying Chain and Datum Dimensions

Individual segments can be inserted or deleted within chain and datum dimension groups. Creo Elements/Direct Drafting automatically adjusts other segments within the chain or datum group to account for the new/deleted segment. Optionally, Creo Elements/Direct Drafting can check to ensure that the modified chain or datum group will not intersect existing geometry.

Deleting a Segment

To delete a segment from an existing chain or datum dimension group:

1. Pick **MODIFY** from the **DIMENSION 2** screen menu.
2. Pick **DELETE DIM**.
3. Identify the dimension text of the segment to be deleted.
4. If the segment you are deleting is part of a dimension chain, identify the dimension text of the next segment in the chain. This segment will grow to fill the space created by the segment you delete.
5. When you have finished deleting dimensions, press **END** to end this command.

Inserting a New Segment

To insert a new segment into an existing chain or datum dimension group:

1. Pick **MODIFY** from the **DIMENSION 2** screen menu.
2. Pick **INSERT DIM**.
3. Identify the chain or datum group you want to modify by picking on the dimension text of any segment within the group.
4. Identify the new dimension point.
5. When you have finished inserting segments, press **END** to end this command.

Modifying a Dimension Vertex

The dimension vertex can be relocated to a new position without the need to pick the first point again.

Figure 161. Relocating a Dimension Vertex

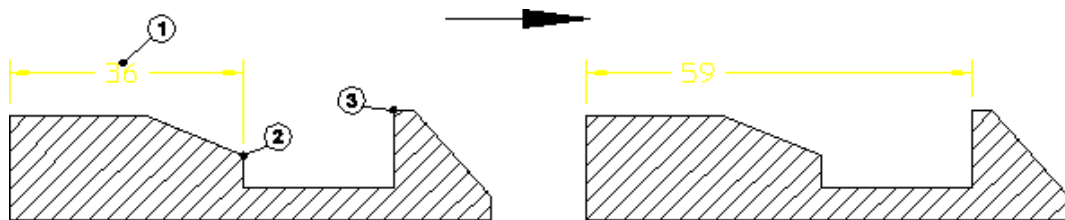

To modify a dimension vertex:

1. Pick **MODIFY** in **DIMENSION 2**.
2. Pick **Keep Text** in **CHG VERTEX**.
3. Identify the dimension, point 1.
4. Pick the old reference element, point 2.
5. Pick the new reference element, point 3.

Creo Elements/Direct Drafting relocates the dimension, but leaves the dimension text in its original position. If you pick **Move Text**, you can also relocate the dimension text.

Grouping

You can group annotations together. [Groups on page 534](#) may consist of a single dimension, multiple text elements and multiple symbols.

Further Information

For further technical information about dimensions, refer to the Creo Elements/Direct Drafting help system:

Enter `help da_dimension` at the Creo Elements/Direct Drafting command line.

The screen will clear and Creo Elements/Direct Drafting will display further information about dimensioning.

9

Hatching a Drawing

Hatching a Drawing Area	307
Converting Hatch to Geometry	309
Deleting Hatching	310
Setting Hatch Parameters	310
Setting the Hatch Linetype and Color	312
Setting Hatch Patterns	313
Changing Hatch	315
Hatching Around Text and Dimension Text	318
Setting Up Standard Hatch Patterns	319
Further Information	321

This chapter shows how to hatch your drawing and how to set and change the hatch parameters.

If you wish to crosshatch an area or build up a custom hatch pattern, simply use any number of **START** commands on the same area but with different hatch angles, distances, hatch points, colors, and linetypes.

Hatching a Drawing Area

This section shows how to hatch your drawing.

The two command options are:

- Auto
- Manual

Automatic Hatching

This is the default option. You can hatch any area fully enclosed by drawing lines or already hatched.

To automatically hatch a drawing area:

1. Press **HATCH**.
2. Pick **Auto** in **START**.
3. Indicate a point inside the area to be hatched.

The cursor will automatically track around the enclosing polygon and then search for any inner holes. Having established the inner and outer contours, Creo Elements/Direct Drafting will hatch the bounded area. If Creo Elements/Direct Drafting finds any gaps or incorrectly split lines in the enclosing polygon, the command is aborted and Creo Elements/Direct Drafting marks the gap or split line.

Manual Hatching

Manual hatching is used to hatch any area not fully enclosed by drawing lines.

To manually hatch a drawing area:

1. Press **HATCH**.
2. Pick **Manual** in **START**.
3. Indicate the start point on the existing outer contour of the area to be hatched. See [Automatic Splitting on page 309](#) for further contour creation options.
4. Continue by indicating successive points around the outer contour.
5. Pick the start point again to close the contour.

When you have closed the contour, you can indicate any inner holes that are not to be hatched in a similar manner.

6. Press **END** and Creo Elements/Direct Drafting will hatch the area.

To abort the command press **CANCEL**. Use **UNDO** to undo erroneous points.

If a side consists of a complete drawing line, simply indicate a mid-point on the line using the element (**ELEM**) catching mode. Creo Elements/Direct Drafting will accept the line. If you wish to identify only part of a line, mark the desired end point with a construction line, use the intersection (**INTERS**) catching mode, and indicate the desired end point. Creo Elements/Direct Drafting will then accept only part of the line.

A series of connected drawing lines can be indicated by the end of one line and the mid-point of the last line. Creo Elements/Direct Drafting will not accept a series of successive lines if there is a branch at one of the vertices.

Figure 162. Indicating the Area for Hatch on page 308 illustrates the above techniques.

Figure 162. Indicating the Area for Hatch

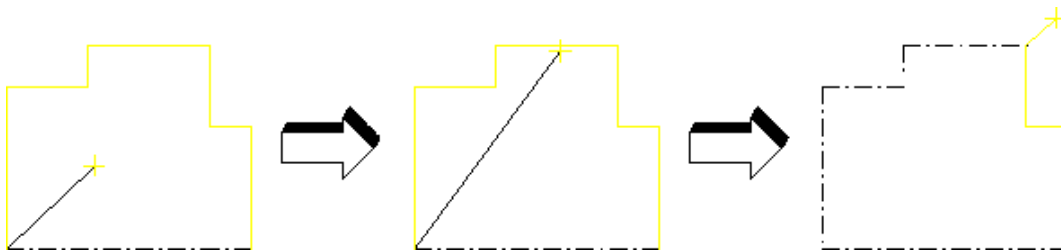

Not all the sides have to be drawing lines. An imaginary line can be used to separate free space or existing points. See Figure 163. Hatching — Leaving an Unhatched Area on page 308.

Figure 163. Hatching — Leaving an Unhatched Area

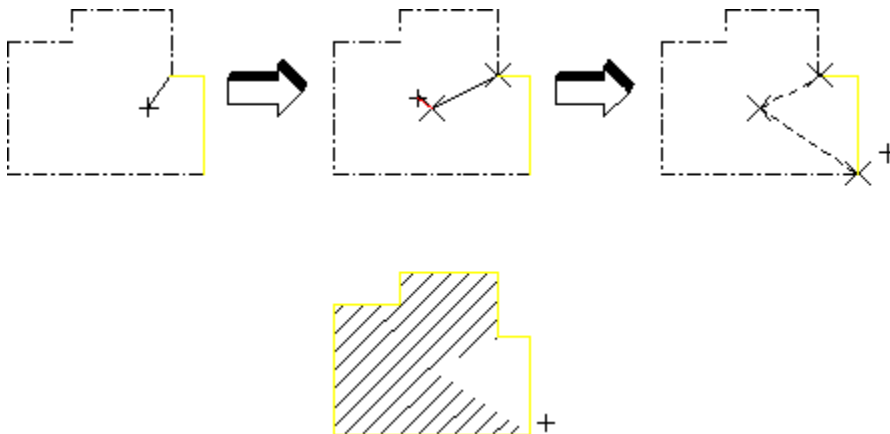

Automatic Splitting

You can use automatic splitting options for extended contour creation functionality. To enable these options, click **Setup ► Hatch ► HATCH_AUTO_SPLIT**. Turn this option on. Use these options to automatically detect element intersections and add only parts of elements to contours.

- Use **Next Point** to automatically create a split point at the pick point on a selected element and use that element as the contour element if it is connected to previously selected element. All elements connecting currently picked and previously picked elements are included in the contour. This option remains active until you select another option (Intersect, Next Point).
- Use **Intersect** to automatically find the next intersection of elements on the contour and splits them both at that point. Drafting starts searching for an intersection along the contour in the same direction as between the previous and current pick points. All elements connecting the previously picked element and the intersection are included in the hatch contour. If Drafting doesn't find an intersection, this option behaves the same as the No Split option. This option remains active until you select another option (Intersect, Next Point).
- Use **No Split** to restore default behavior. The command behaves as if the Automatic Split for Hatch Manual setting is off. This option remains active until you select another option (Intersect, Next Point).
- Use **Direct** to automatically split element at the pick point, and directly connect it to your previous pick point without following the contour. This option remains active only for one pick.

Converting Hatch to Geometry

Hatches are handled differently by different applications. In some cases hatch that is passed from OSD to Autocad can change appearance. To make sure your hatch does not change appearance, convert it to geometry:

1. Click **HATCH**.
2. Click **HATCH->GEO**.
3. "Identify hatch to convert it to the geometry" prompt appears. Click in your viewport window or use the SELECT function to select hatches in the current part. GLOBAL selection is not available.
4. Click **CONFIRM**.
5. Click **END**.

The appearance of your hatching does not change, but it is now geometry. For example, you can delete a single line of the hatch. Completely filled hatches will not convert. In this case, you will see the error message, "Completely filled hatches can not be converted to geometry" or "Some hatches will not be converted to geometry." You can use UNDO and REDO in combination with Hatch-Geo.

Deleting Hatching

This section shows how to delete areas of hatching.

To delete an area of hatching:

1. Press **HATCH**.
2. Pick **DELETE** in **HATCH**.
3. Identify individual areas of hatching to be deleted, (or enclose a group of hatched areas in a box). Alternatively:
 - Use the **SELECTION** block as you would for a normal deletion.
 - Finish by pressing **CONFIRM** to delete the selected groups of hatching.
4. If you delete an area by mistake, press **UNDO** to undo the last delete operation.
5. Press **END** to end the command.

Delete hatch that has been converted to geometry the same way you would delete geometry, using the DELETE command.

Setting Hatch Parameters

This section shows how to set hatch parameters before you begin to hatch.

The three command options are:

- Angle
- Distance
- Match Pt (Match Point)

Hatch Angle

This is the default option. The angular units will be those you selected in the **SETUP** module. A zero value is horizontal and a positive angle results in counterclockwise rotation.

[Figure 164. Positive Hatch Angle on page 311](#) shows a positive angle of hatch.

Figure 164. Positive Hatch Angle

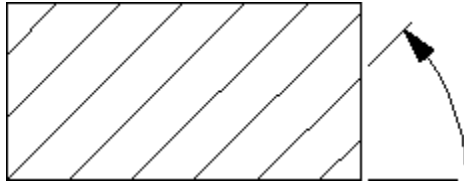

To set the hatch angle:

1. Press **HATCH**.
2. Pick **Angle** in **SET**.

The current hatch angle will be displayed in the System Prompt Line.

3. Enter the new value and all subsequent hatch lines will be drawn at the new hatch angle.

Hatch Distance

You can set the distance between each hatch line for all subsequent hatching. [Figure 165. Hatch Pattern Line Distance on page 311](#) shows hatch pattern line distance.

Figure 165. Hatch Pattern Line Distance



To set the hatch distance:

1. Press **HATCH**.
2. Pick **Distance** in **SET**.

The current line distance will be displayed in the System Prompt Line.

3. Enter the new value.

All subsequent hatch lines will be drawn with the new hatch line distance.

Match Point

You can set a match point to be used for all subsequent hatching. One hatch line will be aligned to pass through the match point. The match point need not necessarily lie inside an area to be hatched; in this case an imaginary extension of the hatch lines would pass through the hatch point.

Figure 166. Hatch Pattern Aligned with Match Point on page 312 shows the hatch pattern aligned with an external match point.

Figure 166. Hatch Pattern Aligned with Match Point

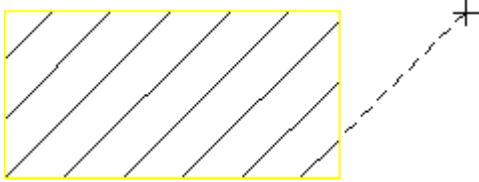

To set the hatch match point:

1. Press **HATCH**.
2. Pick **Match Pt** in **SET**.

Creo Elements/Direct Drafting displays the current coordinates through which the aligned hatch line passes through in the System Prompt Line.

3. Indicate or enter the point with which all hatching must be aligned.

One hatch line of all subsequent hatching will pass through the new match point.

Setting the Hatch Linetype and Color

In addition to setting the hatch angle and line distance, it is possible to select different linetypes and colors. This can be useful for distinguishing materials, components, and so on.

Hatch Linetype

To set the hatch linetype:

1. Press **HATCH**.
2. Pick the required hatch command.
3. Press the required linetype in the **LINETYPE** block.

The selected linetype will be used for all subsequent hatching.

Note

If Hatch Pattern is active, no interactive change is possible. The hatch linetype of the active hatch pattern is used.

Hatch Color

To set the color of all subsequent hatch lines:

1. Press **HATCH**.
2. Pick the required hatch command.
3. Press the desired color on the **COLOR** block.

All subsequent hatch lines will be drawn in the new color.

Note

If Hatch Pattern is active, no interactive change is possible. The hatch color of the active hatch pattern is used.

Setting Hatch Patterns

This section shows how to create or cancel a pattern used to hatch areas. Patterns consist of any number of simple hatch lines built up in layers. When you have created a pattern it will be active every time you use the **START** command. The pattern will be used to hatch all subsequent areas.

The two command options are:

- Create
- Cancel

Creating a Hatch Pattern

Each layer of the pattern is defined by entering five values. The five values correspond to the hatch parameters set using the **SET PATT** command.

The five values used to define the hatch pattern are described in [Table 7. Hatch Pattern Parameters on page 314](#).

Table 7. Hatch Pattern Parameters

Name	Allowed Value	Description
OFFSET	0 to 1	The offset is used to align the hatch lines of the layer to the match point (set using SET Match Point). The perpendicular offset is the entered value multiplied by the SET Distance value. See Figure 167. Hatch Perpendicular Offset on page 315
DIS-TANCE	Any Number	The distance between each of the layer's hatch lines will be the entered value multiplied by the SET Distance value.
ANGLE	0 to ± 360	The entered angle will be added to the SET Angle value to determine the actual angle at which the layer's hatch lines will be drawn
COLOR		Any of the eight Creo Elements/Direct Drafting standard colors may be entered: <ul style="list-style-type: none"> • BLACK • BLUE • CYAN • GREEN • MAGENTA • RED • WHITE • YELLOW
LINE-TYPE		Any of the eight Creo Elements/Direct Drafting standard linetypes may be entered: <ul style="list-style-type: none"> • SOLID • LONG_DASHED • DASH_CENTER • DASHED • DOTTED • DOT_CENTER • PHANTOM

Figure 167. Hatch Perpendicular Offset

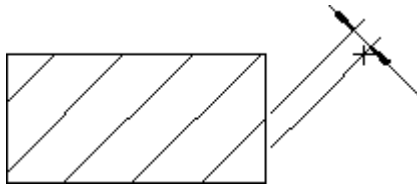

To set the hatch pattern:

1. Press **HATCH**.
2. Pick Create in **SET PATT**.
3. Enter the first layer's values for Offset, Distance, Angle, Color and Linetype.
4. Enter the next layer's values or finish the pattern by pressing **CONFIRM**.

There is no limit to the number of layers in a pattern. For examples of patterns, refer to the section [Setting Up Standard Hatch Patterns on page 319](#). The exact values required for each standard pattern are listed there.

Canceling a Hatch Pattern

You can cancel any previously created hatch pattern. After canceling the hatch pattern all future **START** commands will revert to the hatch parameters set using the linetype block, color block and the **SET** command.

To cancel a hatch pattern:

1. Press **HATCH**.
2. Pick **Cancel** in **SET PATT**.

The previously created hatch pattern will be canceled.

Changing Hatch

This section shows how to change the type of hatching used. The six command options are:

- Angle
- Distance
- Match Pt (Match Point)
- Pattern
- Color
- Linetype

Change Angle

This is the default option.

To change the hatch angle:

1. Press **HATCH**.
2. Pick Angle in CHANGE.
3. Enter the required hatch angle.
4. Identify the hatching to be changed. You can identify individual areas of hatch, box several, or press **ALL**. Creo Elements/Direct Drafting will change the selected hatching.

Alternatively, use the **SELECTION** block as you would for a **DELETE** command, and finish by pressing **CONFIRM**.

Change Distance

To change the line distance of an existing hatch:

1. Press **HATCH**.
2. Pick Distance in CHANGE.
3. Enter the required line distance.
4. Identify the hatching to be changed. You can identify individual areas of hatch, box several, or press **ALL**. Creo Elements/Direct Drafting will change the selected hatching.

Alternatively, use the **SELECTION** block as you would for a **DELETE** command, and finish by pressing **CONFIRM**.

Change Match Point

To change the hatch match point:

1. Press **HATCH**.
2. Pick Match Pt in CHANGE.
3. Enter the required point for the hatch lines to match.
4. Identify the hatching to be changed. You can identify individual areas of hatch, box several, or press **ALL**. Creo Elements/Direct Drafting will change the selected hatching.

Alternatively, use the **SELECTION** block as you would for a **DELETE** command, and finish by pressing **CONFIRM**.

Change Pattern

To change a hatched area to a new pattern:

1. Press **HATCH**.
2. Pick Pattern in **CHANGE**.
3. Enter the five values to define the first layer of the pattern (full details of the five values are given in "Creating a Hatch Pattern").
4. If there are further layers, continue by entering the next layer's five values.
5. Finish defining the pattern by pressing **CONFIRM**.
6. Identify any hatched areas and Creo Elements/Direct Drafting will change them to the new pattern.

Alternatively, select Pattern from the screen menu and identify an existing pattern. Identify the hatching to be changed and it will be redrawn with the chosen pattern.

Change Color

To change the color of an existing hatch:

1. Press **HATCH**.
2. Pick **Color** in **CHANGE**.
3. Indicate the color required from the **COLOR** block on the tablet.
4. Identify the hatching to be changed.

You can only identify individual areas of hatch to be changed. When there are two hatch patterns superimposed on each other, the pattern nearest to the cursor will be changed.

Alternatively use the **SELECTION** block as you would for a **DELETE** command, and finish by pressing **CONFIRM**.

Change Linetype

To change the hatch linetype:

1. Press **HATCH**.
2. Pick **Linetype** in **CHANGE**.
3. Press the linetype required on the **LINETYPE** block.
4. Identify the hatching to be changed.

You can only identify individual areas of hatch to be changed. When there are two hatch patterns superimposed on each other, the pattern nearest to the cursor will be changed.

Alternatively, use the **SELECTION** block as you would for a **DELETE** command, and finish by pressing **CONFIRM**.

Hatching Around Text and Dimension Text

When text lies in a hatched area, Creo Elements/Direct Drafting automatically creates a window around the text. The result is the same whether you hatch first and then add text, or add text first. (Previously, this applied to dimension text only.) If later you modify the drawing by moving the text, the hatching is automatically updated.

The **TXT WINDOW** command creates a hole around text and dimension text when the text runs through a hatched area (as in overlapping parts). The following figure shows three parts in a parts structure (part 1 is the top part and part 3 is the lowest part). In a real assembly, the parts overlap and the hatching on parts 1 and 2 appears to run through the dimension text on part 1. You use the **TXT WINDOW** command to punch a window through the overlapping hatching.

Figure 168. Text and Dimension Text: Hatched Area

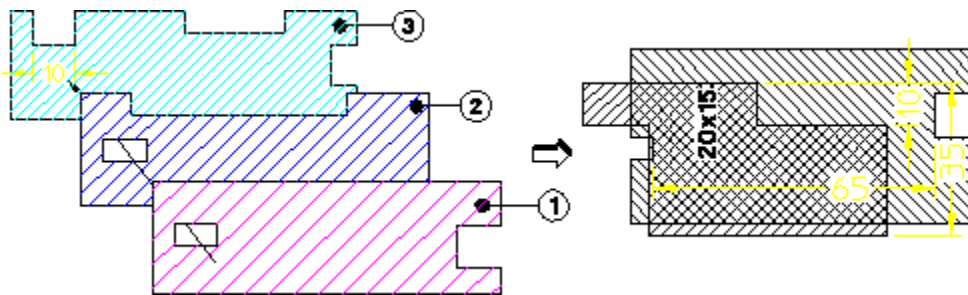

1. Press **HATCH**.
2. Pick **Auto** or **Manual** in **START** and hatch the required area.
3. Pick **TXT WINDOW** in **HATCH**.
4. Identify the dimension text that you want to hatch around.

Figure 169. Hatching Around Dimension Text

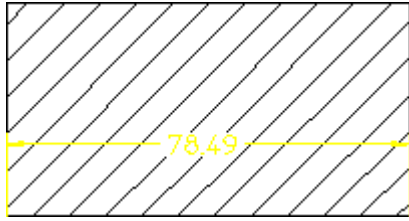

To move dimension text when you have used the TXT WINDOW command to create the hole around the text:

1. Move the dimension text to its new position.
2. Delete the old hole in the hatching (Creo Elements/Direct Drafting deletes the hole and regenerates the hatch).
3. Use the TXT WINDOW command to create a new hole around the dimension text.

Setting Up Standard Hatch Patterns

This section shows how to set up standard hatch patterns which will be used by all subsequent START commands.

To set up a standard hatch pattern:

1. Press **HATCH**.
2. Pick **STANDARDS** in **HATCH**.
3. Pick the desired option (Iron, Steel, Copper).

The hatch pattern will become active.

The three standard options are shown below together with the values of offset, distance, angle, color, and linetype used (refer to "Setting Hatch Patterns"). All the examples shown are drawn with the following hatch parameters: hatch angle 45, hatch distance 5, and match point 0,0.

Standard Hatching — Iron

This option sets the following Hatch Pattern values:

OFFSET: 0

DISTANCE: 1

ANGLE: 0

COLOR: CYAN

LINETYPE: SOLID

Figure 170. Iron

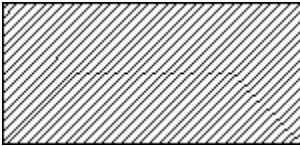

Standard Hatching — Steel

This option sets the following Hatch Pattern values:

OFFSET: 0.33 & 0

DISTANCE: 1 & 1

ANGLE: 0 & 0

COLOR: CYAN & CYAN

LINETYPE: SOLID & SOLID

Figure 171. Steel

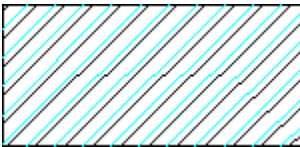

Standard Hatching — Copper

This option sets the following Hatch Pattern values:

OFFSET: 0.5 & 0

DISTANCE: 1 & 1

ANGLE: 0 & 0

COLOR: CYAN & CYAN

LINETYPE: DASHED & SOLID

Figure 172. Copper

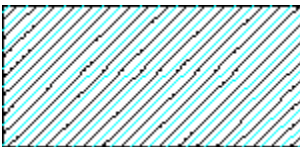

Further Information

For further technical information about hatching, refer to the Creo Elements/Direct Drafting help system:

Enter `help hatching` at the Creo Elements/Direct Drafting command line.

The screen will clear and Creo Elements/Direct Drafting will display further information about hatching.

10

Adding Text to a Drawing

Entering Text.....	323
Editing and Deleting Text	326
Setting Text Parameters.....	327
Modifying Text.....	330
Drawing Leaders and Terminators	333
Setting Terminator Size and Type	333
Setting Fonts.....	334
Setting the Text Frame.....	336
Changing Text.....	337
Changing the Text Frame.....	340
Listing Fonts	340
Changing Fonts.....	341
Font Editor.....	341
Converting Text to Geometry (DXF/DWG and IGES 2D Translation).....	345
Grouping	345
Further Information.....	345

Entering Text

This section shows how to:

- Enter and position text on a drawing.
- Plant text on a drawing.

Note

If Creo Elements/Direct Drafting draws boxes instead of the text, you must input a text font. Refer to [Setting Fonts on page 334](#).

ENTER has the following two options:

- Line
- Inplace
- Screen

Line

This is the default option.

To add single lines or simple blocks of text to your drawing:

1. Press **TEXT 1**.
2. Pick Line in ENTER.
3. Enter the desired text in the User Input Line. The text must be enclosed in quotes (' ' or " ").
4. Indicate the location for the text.

Creo Elements/Direct Drafting draws the text.

If you require the same text at several locations on the drawing, simply continue to indicate locations and the text will be repeated.

Example

The following example shows how to enter a simple block of text by entering each line of text in quotes (either ' ' or " ").

To enter a block of text using the line option:

1. Press **TEXT 1**.
2. Pick Line in ENTER.
3. Enter the following lines of text, pressing [Enter] on completion of each line.

```
"This is a demonstration"  
  "of how to enter"  
  "a block of text"  
  "line by line"
```

4. Indicate the location for the text.

Creo Elements/Direct Drafting will display the following:

```
This is a demonstration  
of how to enter  
a block of text  
line by line
```

Example

The following example shows how to force Creo Elements/Direct Drafting not to start a new line by using the "\" character (backslash):

1. Press **TEXT 1**.
2. Pick LINE in Enter.
3. Enter the following lines of text (including spaces), pressing [Enter] on completion of each line.

```
"This is a demonstration \  
of how to stop \  
Creo Elements/Direct Drafting forcing a new line"
```

4. Indicate the required location for the text.

Creo Elements/Direct Drafting will display the following:

```
This is a demonstration of how to stop  
Creo Elements/Direct Drafting forcing a new line
```

Inplace

To enter text directly in your drawing:

1. Press **TEXT 1**.
2. Pick Inplace in ENTER.
3. Use the edit keys and keyboard to enter the required text. It is not necessary to use quotes. To force a new line use either the [Enter] key or the edit keys.
4. When you have finished entering text, press [Ctrl] [D].

Screen

To add large blocks of text to your drawing:

1. Press **TEXT 1**.
2. Pick Screen in ENTER.

-
- The normal display will be replaced by a blank screen.
3. Use the edit keys and keyboard to enter the required text. It is not necessary to use quotes. To force a new line use either the [Enter] key or the edit keys.
 4. When you have finished entering text press [Ctrl] [D].
The normal display will reappear.
 5. Indicate the desired location for the block.
Creo Elements/Direct Drafting will draw the block of text.

Cutting and Pasting with the Mouse

Text displayed in a non-Drafting window can be copied (by dragging the mouse over it) and pasted on the user input line or into the Creo Elements/Direct Drafting text editor. You must first copy the text to the clipboard.

To copy text:

1. Display the (terminal) window containing the text
2. Click the beginning of the text string and drag the cursor over the text
3. Release the mouse

To paste text:

1. Click ENTER in **TEXT 1**
2. Type in the start-quote character (')
3. Click the middle mouse button
4. Type in the end-quote character (')
5. Press [Enter]
6. In the Creo Elements/Direct Drafting drawing area, click the left mouse button to place the text

Text can be pasted onto the user input line or in the Creo Elements/Direct Drafting editor only. It cannot be pasted directly into the drawing area.

Planting Text Attributes

If required, you can plant an invisible point containing text attributes on the screen. These attributes will be added to any text input when you edit the point at a later date.

To plant an invisible point containing text attributes on the screen:

1. Press **TEXT 1**.
2. Pick any or all of the text attributes in SET.

-
3. Pick Line in ENTER and type in two single or double quotation marks. The quotation marks must be separated by at least one blank space.
 4. Indicate a point on your drawing.

To add text to this point using EDIT in the same drawing session, or during subsequent drawing sessions:

1. Press **POINTS ON** in **SHOW**.
2. Identify the point previously planted.
3. Enter the required text.

The new text will be displayed in the attributes that you selected when you planted the point.

Editing and Deleting Text

To edit existing text in a separate screen:

1. Press **TEXT 1**.
2. Pick EDIT.
3. Identify the text to be edited.

The normal display will be replaced by a blank screen containing the text to be edited.

4. Use the keyboard and edit keys to make the required changes to the text.
5. Press [Ctrl] [D].

The normal display will reappear and Creo Elements/Direct Drafting will change the identified text.

To edit text directly in the drawing:

1. Press **TEXT 1**.
2. Pick Inplace in EDIT.
3. Identify the text to be edited.
4. Use the keyboard and edit keys to make the required changes to the text.
5. Press [Ctrl] [D].

The EDIT CONV command is included in the **TEXT 1** menu for convenience. It is the same command as displayed in the **SYMBOLS 1** menu and is used to allow editing of symbol-type fonts. For more information about its use, see [Symbol Examples on page 354](#).

Creo Elements/Direct Drafting deletes text in the same way as normal drawing lines. To delete text without using the selection block:

-
1. Press **DELETE**.
 2. Box the text to be deleted, or indicate a single piece of text.
Creo Elements/Direct Drafting will now delete the identified text. Press **UNDO** to correct mistakes and then repeat the operation or end the command.

To delete text using the selection block:

1. Press **DELETE**.
2. Select text for deletion using the **SELECTION** block options just as you would for a normal **DELETE** command. You can press **UNDO** to correct any mistakes.
3. Press **CONFIRM**.
Creo Elements/Direct Drafting deletes the selected text.

Setting Text Parameters

This section shows how to alter the appearance of all subsequent text.

Pick any of the following eight options in SET to enter new text parameters:

- Angle
- Linespace
- Size
- Ratio
- Slant
- Adjust
- Fill On
- Fill Off

Angle

Angle is the default option in SET.

[Figure 173. Setting the Text Angle on page 327](#) shows the text angle.

Figure 173. Setting the Text Angle



To set the text angle:

1. Press **TEXT 1**.

-
2. Pick **Angle** in **SET**.

The present text angle will be displayed (the angular units will be those selected in the **SETUP** menu, zero is horizontal and a positive angle results in counterclockwise rotation).

3. Enter the new angle or indicate two points defining the angle.

The entered/indicated angle will now be used for all subsequent text.

Linespace

You can set the line spacing used in all subsequent blocks of text. Creo Elements/Direct Drafting has a default of 2.2 mm. The distance between lines of text in a block is as follows:

Actual line spacing = Linespace * Text Size

To set the linespace:

1. Press **TEXT 1**.
2. Pick **Linespace** in **SET**.

The present line spacing will be displayed.

3. Enter the required value.

All subsequent blocks of text will be spaced using the new value.

Size

You can set the size (height) of all subsequent text. Creo Elements/Direct Drafting has a default of 3.5 mm or equivalent (that is, depending on the **SETUP** condition).

To set the text size:

1. Press **TEXT 1**.
2. Pick **Size** in **SET**.

The present text size will be displayed.

3. Enter the new text size value.

All subsequent text will be drawn to the new size.

Ratio

You can set the width to height ratio of all subsequent text characters. Creo Elements/Direct Drafting has a default of 1.0. To set the character width to height ratio:

1. Press **TEXT 1**.

2. Pick **Ratio** in **SET**.

The present width-to-height ratio for text characters will be displayed.

3. Enter the new value.

All subsequent text will be drawn with the new ratio.

Slant

You can set the slant angle for all subsequent text characters. Creo Elements/Direct Drafting has a default of 0.

Figure 174. Text with a 15° Slant on page 329 shows text with a 15° slant.

Figure 174. Text with a 15° Slant



To set the text slant:

1. Press **TEXT 1**.
2. Pick **Slant** in **SET**.

The present slant angle for text characters will be displayed (the angular units will be those previously selected in the **SETUP** menu).

3. Enter the new angle (zero is perpendicular to the text line, and a positive angle causes clockwise rotation).

All subsequent text will be drawn with the new slant.

Adjust

You can adjust the position of the cursor in the text box when locating text on the screen. This is useful for aligning text in tables.

To adjust the position of the cursor in the text box:

1. Press **TEXT 1**.
2. Pick **Adjust** in **SET**.

The present cursor positioning in the text box will be displayed by a number between 1 and 9. [Figure 175. Cursor Positions in the Text Box on page 330](#) shows the numbers and the corresponding cursor positions in the text box.

Figure 175. Cursor Positions in the Text Box

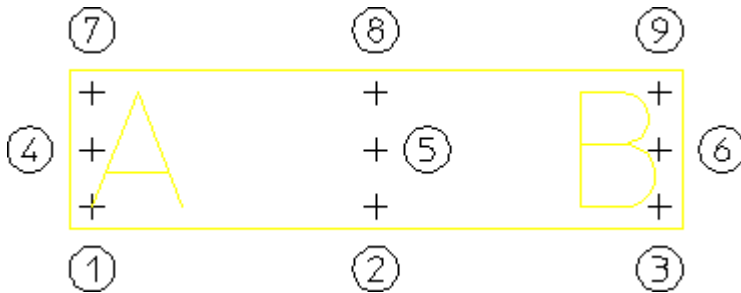

3. Enter a new value between 1 and 9.

The cursor will be in the new position for all subsequent text positioning.

Fill On/Off

You can set all subsequent text to be drawn with each character filled. This will only affect text fonts that can be filled such as " hp_block_c "

[Figure 176. Unfilled and Filled Text on page 330](#) shows an example (unfilled and filled).

Figure 176. Unfilled and Filled Text

ABCDE

ABCDE

To fill text fonts:

1. Press **TEXT 1**.
2. Pick **Fill On** in **SET**.

Similarly, to set Creo Elements/Direct Drafting to unfill text fonts, pick Fill Off in SET.

Modifying Text

This section shows how to modify lines and blocks of text. First you must decide if you want to keep the original text by choosing one of the MODIFY options.

The MODIFY options are:

- Keep
- No Keep

To leave the original text unchanged after a **MODIFY** operation, pick **Keep** in **MODIFY**.

To delete the original text after a **MODIFY** operation, pick **No Keep** in **MODIFY**.

Moving Text

To move lines or blocks of text:

1. Press **TEXT 1**.
2. Pick **No Keep** in **MODIFY**.
3. Identify the text to be moved. You can either box it or use the **SELECTION** block.
4. Pick **MOVE**.
5. Identify a reference point for the move.
6. Indicate the desired destination for the reference point.

Creo Elements/Direct Drafting will redraw the text. Press **UNDO** to undo the move and reposition the reference.

Copying Text

To copy lines or blocks of text:

1. Press **TEXT 1**.
2. Pick **Keep** in **MODIFY**.
3. Identify the text to be copied. You can either box it or use the **SELECTION** block.
4. Pick **MOVE**.
5. Identify a reference point for the copy.
6. Indicate the destination point.

Creo Elements/Direct Drafting will now copy the text. Press **UNDO** if you make a mistake.

Rotating Text

To rotate text:

1. Press **TEXT 1**.
2. Pick **Keep** or **No Keep** in **MODIFY**.
3. Identify the text to be rotated, you can either box it or use the **SELECTION** block.

4. Pick **ROTATE**.
5. Indicate the center for rotation.
6. Enter the angle of rotation.

Creo Elements/Direct Drafting will now rotate the text. Press **UNDO** if you make a mistake.

Mirroring Text

This section describes how text is mirrored and kept readable. The **MIRROR** command itself is located in the **MODIFY 1** menu but is included here for convenience. (See also [Mirroring Drawings on page 165](#).)

To mirror text about two points (default):

1. Press **MODIFY 1**.
2. Click **Keep** in **MODIFY**.
3. Click **2 Pts** in **MIRROR**.
4. Indicate two points on the line of symmetry.
5. Identify the text to be mirrored (1).

The line of symmetry in [Figure 177. Mirroring Text on page 332](#) is the dashed line (2).

Figure 177. Mirroring Text

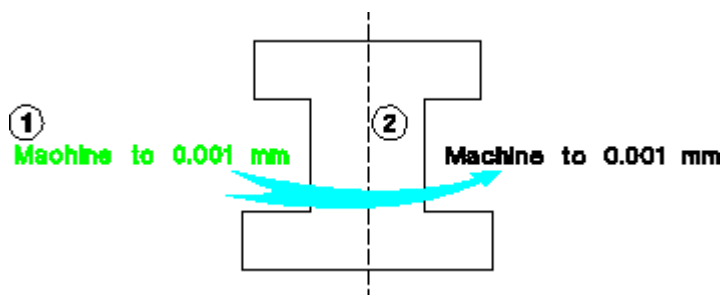

To mirror text about a horizontal or a vertical:

1. Press **MODIFY 1**.
2. Click **Keep** in **MODIFY**.
3. Click **Horizontal** or **Vertical** in **MIRROR**.
4. Indicate a point on the line of symmetry.
5. Identify the text to be mirrored.

The default for mirroring text is `KEEP_READABLE`. If you do not want the text to be kept readable (as in previous releases), you must enter the full command, for example: `MODIFY MIRROR VERTICAL`.

Drawing Leaders and Terminators

This section shows how to draw leader arrows on your drawing. The type and size of the terminator is set by picking `TERMINATOR`. For deletion purposes, the leader line is considered as a single element and can be deleted in one operation.

The three leader line options are:

- Start
- Gap
- Finish

To draw a leader line:

1. Press **TEXT 1**.
2. Pick **Start** in **LEADER**.
3. Indicate the start of the line and then successive points.

If you wish the leader line to be broken – for example, to allow the leader line to cross an area of drawing:

- a. Pick **Gap** in **LEADER** at the break point.
- b. Indicate the restart point of the line and continue as before.

Press **UNDO** if you make a mistake.

4. Pick **Finish** in **LEADER**.

Creo Elements/Direct Drafting will draw the leader line complete with terminator.

Setting Terminator Size and Type

You can set the size and type of terminator used in the `LEADER` command.

The `TERMINATOR` options are:

- Arrow
- Triangle
- Slash
- Dot
- None

-
- Size
 - Jis

To set the size and type of terminator:

1. Press **TEXT 1**.
2. Pick **TERMINATOR** in **TEXT 1**.
3. Enter the terminator size (Size is the default option in TERMINATOR).
4. Pick the type of terminator you require (Arrow, Triangle, Slash, Dot, Jis, or None).

If you wish to change the type of terminator but leave the size unaffected, simply pick TERMINATOR followed by the relevant option.

Setting Fonts

You can set the text font to be used for all subsequently entered text. To set the default text font, pick SET FONT.

To set the current font:

1. Click **SET FONT** in **TEXT 1** (Creo Elements/Direct Drafting switches to the **TEXT 2** menu).
2. Click '**hp_block_v**' in the font list in **TEXT 2**.

The next time you enter text, it is drawn in the new font.

Note the following:

- The fonts `hp_block_c` and `hp_block_v` must be loaded manually.
- Storing of lower version MI files will not be a problem, the store functionalities will require no changes.
- Fonts can be loaded irrespective of the current environment LANG variable.

OSD's different internal and external encoding schemes were [Unicode on page 547](#) incorporated for version 2007.

Changing the Text Font

To change the font of currently-displayed text:

1. Click **CHG FONT** in **TEXT 2**
2. Click `hp_block_v` in the font list
3. Identify the text to be changed

Loading Fonts

Table 8. Creo Elements/Direct Drafting Fonts on page 335 lists the Creo Elements/Direct Drafting fonts.

Table 8. Creo Elements/Direct Drafting Fonts

Font Name	Comments
osd_default	Default OSD font containing hp_i3098_v and hp_kanji2_c characters with variable character spacing
osd_default2	Default OSD font containing hp_i3098_c and hp_kanji2_c with fixed characters spacing
osd_default3	Default OSD font containing hp_d17_v and hp_kanji2_c with variable characters spacing
HP_Y14_5.FNT	Used for symbols only.
HP_BLK_C.FNT	Filled font with constant character spacing.
HP_BLK_V.FNT	Filled font with variable character spacing.
HP_D17_C.FNT	DIN17 font with constant spacing.
HP_D17_V.FNT	DIN17 font with variable spacing.
I3098_C.FNT	ISO3098 font with constant character spacing (=DIN 6776).
I3098_V.FNT	ISO3098 font with variable character spacing (=DIN 6776).
HP_JAS_C.FNT	Kanji Japanese font with constant character spacing.
HP_JAS_V.FNT	Kanji Japanese font with variable character spacing.
HP_SYMS.FNT	Symbols font.
HP_SYMS2.FNT	Symbols font.

If a particular font set has not been input into your hardware's memory, you can not access it. In this case, the font must be loaded:

1. Press **TEXT 1**.
2. Click **LOAD FONT**.
3. Enter the name of the font required, enclosed in quotation marks.

Having loaded a font set, you must make it current if you wish to use it.

4. Enter `CURRENT_FONT "fontname"`
where fontname is the full path name of the font-set file.

Automatically Loaded Fonts

In some cases, a font may have been saved with an MI file. In this case, Creo Elements/Direct Drafting will automatically load the font when you load the MI file. If you don't want Creo Elements/Direct Drafting to read this new font, use the command, `LOAD` with the option `DISCARD FONTS`.

Occasionally, one of these file-associated fonts will bear the same name, but not the same definition, as a font already in your system. Creo Elements/Direct Drafting will prompt you to overwrite or rename the MI font. Or, you can use the option `OVERWRITE_FONTS` when you load the drawing to overwrite the system font with the new MI font.

Saving Fonts

If you store an MI file, you also have the option of storing the fonts you used to create the drawing text. While this adds to the size of the file, it ensures that anyone else opening your file will see your text. To do this, specify `ADD_FONTS` when you `STORE` your drawing.

Setting the Text Frame

Pick `SET FRAME` to set the type of frame drawn around all subsequent lines and blocks of text.

The command has the following options:

- Off
- Balloon
- Box
- Flag

Setting the Text Frame Off

This is the default option. Pick `Off` in `SET FRAME` and all subsequent text will be drawn without a surrounding frame.

Balloon Frame

Pick `Balloon` in `SET FRAME` and all subsequent text will be drawn surrounded by rounded boxes. [Figure 178. Text with a Balloon Frame on page 337](#) shows text with a balloon frame.

Figure 178. Text with a Balloon Frame



Box Frame

Pick Box in SET FRAME and all subsequent text will be drawn surrounded by a rectangular frame. [Figure 179. Text with a Box Frame on page 337](#) shows text with a box frame.

Figure 179. Text with a Box Frame



Flag Frame

Pick Flag in SET FRAME and all subsequent text will be drawn surrounded by a flag frame. [Figure 180. Text with a Flag Frame on page 337](#) shows text with a flag frame.

Figure 180. Text with a Flag Frame



Changing Text

This section shows how to change any line or block of text.

The eight CHANGE command options are:

- Angle
- Linespace

-
- Size
 - Ratio
 - Slant
 - Adjust
 - Fill on
 - Fill off

Change Angle

To change the text angle:

1. Press **TEXT 2**.
2. Pick Angle in **CHANGE**.
3. Enter the angle at which the text is to be drawn, or define the angle by indicating two points (for numerical values the angular units will be those selected in the **SETUP** menu. Horizontal is zero and a positive angle will result in counterclockwise rotation).
4. Identify the text to be changed.

Creo Elements/Direct Drafting will redraw it at the new angle. If you wish to change several pieces of text to the new angle, just continue to identify them.

Line Spacing

To change the line spacing of any existing block of text:

1. Press **TEXT 2**.
2. Pick **Linespace** in **CHANGE**.
3. Enter the line spacing factor.
4. Identify the block of text to be changed.

Creo Elements/Direct Drafting will redraw it with the new line spacing. If you wish to change several pieces of text to the new line spacing, just continue to identify them.

Change Size

To change the character size of an existing line or block of text:

1. Press **TEXT 2**.
2. Pick **Size** in **CHANGE**.
3. Enter the new text size.

-
4. Identify the text to be changed and Creo Elements/Direct Drafting will redraw it in the new text size. If you wish to change several pieces of text to the new size, just continue to identify them.

Change Ratio

To change the character width-to-height ratio of any existing line or block of text:

1. Press **TEXT 2**.
2. Pick **Ratio** in **CHANGE**.
3. Enter the new character width to height ratio.
4. Identify the text to be changed and Creo Elements/Direct Drafting will redraw it in the new text ratio. If you wish to change several pieces of text to the new ratio, just continue to identify them.

Change Slant

To change the character slant of any existing line or block of text:

1. Press **TEXT 2**.
2. Pick **Slant** in **CHANGE**.
3. Enter the new character slant (the angular units are degrees, zero is perpendicular to the text line and a positive angle will result in clockwise rotation).
4. Identify the text to be changed.
Creo Elements/Direct Drafting will redraw it at the new slant. If you wish to change several pieces of text to the new slant, just continue to identify them.

Change Adjust

To adjust the position of the cursor in any existing line or block of text, and thus shift the position of the identified text:

1. Press **TEXT 2**.
2. Pick **Adjust** in **CHANGE**.
3. Enter the adjust value required (the value must be between 1 and 9, see "Setting Text Parameters").
4. Identify the text to be changed.
Creo Elements/Direct Drafting will redraw it in the new position. If you wish to adjust several pieces of text, just continue to identify them.

Fill On/Off

To change any existing text to be filled or unfilled:

1. Press **TEXT 2**.
2. Pick **Fill On** or **Fill Off** in **CHANGE**.
3. Identify the text to be changed.

Creo Elements/Direct Drafting will redraw it filled or unfilled. Note that the command only works with fillable fonts. If you wish to fill or unfill several pieces of text, just continue to identify them.

Changing the Text Frame

To change the frame of any line or block of text:

1. Press **TEXT 2**.
2. Pick the required option in **CHG FRAME**.
3. Identify the text to be changed. You can identify individual text, box several pieces of text, press **ALL** to change all text, or use the **SELECTION** block in the normal way.

The command options are:

- Off
- Balloon
- Box
- Flag

Listing Fonts

You can list the following text font information:

- The text fonts that are used in the current drawing.
- The text fonts that are loaded into the hardware's memory.
- The active text font.

To list fonts:

1. Press **TEXT 2**.
2. Pick **LIST FONTS** in **TEXT 2**.
3. Enter the desired location for the fonts list:
 - a. To send the fonts list to the screen, enter **SCREEN**

-
- b. To send the fonts list to a file, enter `DELETE_OLD` or `APPEND` to overwrite or append the file. Enter a filename and the fonts list is sent to the file.

Changing Fonts

To change the text font of any existing text:

1. Press **TEXT 2**.
2. Pick **CHG FONT**.
3. Pick the required font option.
4. Identify the text to be changed.

Creo Elements/Direct Drafting will redraw it in the desired text font. You can identify individual text, box several pieces of text, press **ALL** to change all text, or use the **SELECTION** block in the normal way. Note that if the desired font has not been loaded into memory, the text will be redrawn as boxes, and will remain so until the font is input.

Font Editor

Creo Elements/Direct Drafting's **FONT EDITOR** menu lets you modify existing Creo Elements/Direct Drafting fonts and create new fonts. This special module is particularly useful in design environments where company-specific characters or logos are required and for Japanese Kanji character-sets.

When working with the **FONT EDITOR** menu, note the following:

- Although you can use the **WINDOW** menu to do such things as a redraw, do not change to another menu until you are finished.
- Store the current drawing (MI file).
- When you have finished creating or modifying the font, you must use **STORE** to save it.
- All loaded fonts are listed in the table.
- The font you are editing becomes the current font.

Caution

Before calling the **FONT EDITOR**, save the current drawing. This is because the font editor uses the current drawing area to display the font table and deletes anything in the current workspace.

The FONT EDITOR menu is shown in Figure 181. Font Editor Menu on page 342.

Figure 181. Font Editor Menu

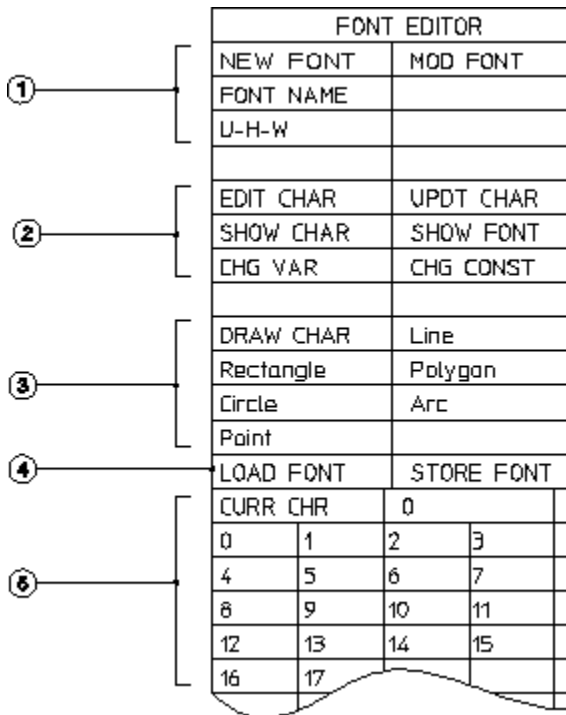

- 1 Creating and modifying a font
- 2 Character and font commands
- 3 Drawing commands
- 4 Loading and saving commands
- 5 Character table (ASCII number)

The commands and options available in this menu are:

NEW FONT	Use this command to specify the name of the font to be created.
MOD FONT	Use this command to specify the font to be edited. Pick MOD FONT and select the font from the fontlist displayed in the lower part of the menu.
FONT NAME	Lets you change the name of the font currently being edited.
U-H-W	Specifies the character geometry (see Figure 182. Character Frame on page 344): <ul style="list-style-type: none"> • U: Distance below the line • H: Height of character • W: Width of character
EDIT CHAR	Use this command to specify the character to edit. The character can be selected: <ul style="list-style-type: none"> • From the character table in the menu

	<ul style="list-style-type: none"> Entered on the command line
UPDT CHAR	Updates the current character
SHOW CHAR	Displays the specified character
SHOW FONT	Displays the specified font
CHG VAR	Changes the spacing between variable-spaced characters.
CHG CONST	Changes the spacing between constant-spaced characters.
DRAW CHAR	Drawing tools to create a character
LOAD FONT	Loads a font
STORE FONT	Stores a font.

Editing a Font

To edit a font:

- Pick **FONT EDIT** in **TEXT 2**

Creo Elements/Direct Drafting displays a warning telling you to save the current drawing. Pick OK to clear the screen.
- Pick **MOD FONT** in **FONT EDITOR**

Creo Elements/Direct Drafting displays a list of currently available fonts.
- Select the font to modify, for example, `hp_symbols2`

Creo Elements/Direct Drafting displays the font name adjacent to the **FONT NAME** field.
- Pick **SHOW FONT** to display the font table.
- Pick **EDIT CHAR**.
- Scroll down the **CURR CHAR** table and select 174. (You can also enter the character number on the command line.)

Creo Elements/Direct Drafting displays the character and a yellow character-frame.
- Delete existing geometry.
- Using the options Line, Rectangle, Polygon, Circle, Arc, or Point in **DRAW CHAR**, create the character shown. (These options work in a similar way as in the **CREATE** menu.) Note that the maximum number of unconcatenated elements in a character is 84.

Figure 182. Character Frame

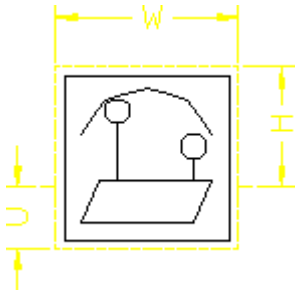

9. Pick **UPDT CHAR**
10. Enter the character number (you can either keep this number or assign a new number)
11. Enter width of new character (you can either keep the current width or specify a new width)
12. Pick **STORE FONT** and press [Enter] to accept the current font name
13. Enter a filename.

Changing the Character Spacing

The spacing between characters can be changed using the following commands:

CHG CONST	Changes the spacing between constant-spaced characters.
CHG VAR	Changes the spacing between variable-spaced characters.

To change the spacing between characters:

1. Pick **CHG CONST** or **CHG VAR** in **FONT EDITOR**.
2. Enter a value (measured in pixels)

The next time you enter text, Creo Elements/Direct Drafting draws the text block with the new character spacing.

Figure 183. Characters with Constant Spacing



Figure 184. Characters with Variable Spacing

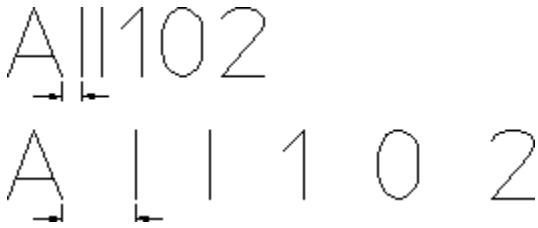

Converting Text to Geometry (DXF/DWG and IGES 2D Translation)

The **Text ► Geo** command converts text entities to geometry entities. This is necessary for translation to DXF/DWG and IGES 2D format when customized fonts have been used (the MI file stores the fontname but does not contain the customized font information).

Note the following:

- Only text entities can be converted, not dimension texts.
- Any text-windows inside hatched areas are retained.

Grouping

You can group annotations together. [Grouping on page 534](#) may consist of a single dimension, multiple text elements and multiple symbols.

Further Information

For further technical information about text, refer to the Creo Elements/Direct Drafting help system:

Enter: `help text` at the Creo Elements/Direct Drafting command line.

The screen will clear and Creo Elements/Direct Drafting will display further information about text.

11

Adding Symbols to a Drawing

Geometric Tolerancing Symbols	347
Surface Symbols	356
Welding Symbols	363
Grouping	371

Geometric Tolerancing Symbols

This section shows how to add geometric tolerancing symbols to your drawing. The symbols are based on the `hp_symbols2` font. When you add symbols to a drawing, Creo Elements/Direct Drafting uses this font.

Press **SYMBOLS 1** to display the **SYMBOLS 1** menu.

A second empty menu is provided for your own personal or company symbol commands. These are written using the Creo Elements/Direct Drafting macro language. To access the second menu pick MENU 2 in SYMBOLS 1.

Setting Symbol Size

The size of symbols and associated text is determined by the SET Size command in the **TEXT 1** menu. Therefore before you start adding symbols to your drawing, set the desired text size as described in [Adding Text to a Drawing on page 322](#).

Deleting and Moving Symbols

Deleting Symbols

Symbols are deleted in the same way as drawing elements and text, that means you press **DELETE** and identify the symbol to be deleted.

Moving Symbols

Pick Move in **MODIFY** and proceed as you would for a normal element such as text, a line, or an arc.

Building Up a Geometric Tolerance Group

The **SYMBOLS 1** menu is divided into sections which allow you to quickly build up the desired geometric tolerance group. [Figure 185. SYMBOLS 1 Screen Menu on page 348](#) shows the **SYMBOLS 1** menu.

Figure 185. SYMBOLS 1 Screen Menu

SYMBOLS 1	
①	TYPE Normal
	Composite
②	FORM Straight
	Flat Round
	Cylinder
	PROFILE Line
③	Surface
	LOCATION Position
	Symmetry Concentric
	ALIGNMENT Angular
④	Perpendic Parallel
	RUNOUT Circular
	Total
⑤	MODIFIERS
	APPEND TXT New Line
	Back Space
⑥	End Frame
	TARGET Symbol
⑦	Point
	REVISION Triangle
⑧	EDIT COM
	MENU 2

- 1 Sets Normal or Composite Tolerances
- 2 Draws Geometric Character Symbols
- 3 Draws Modifying Symbols
- 4 Adds Text to the Symbol Block
- 5 Draws Datum Target and Revision Symbols
- 6 Edits the Symbol

To draw a geometric tolerance group:

1. Press **SYMBOLS 1**.
Set the type of tolerance.
2. Pick Normal or Composite in TYPE.
3. Pick the desired geometric characteristic symbol from the screen menu.
A box representing the symbol will appear on the cursor.
4. Indicate the symbol location.
5. Continue building the tolerance by picking the required items in MODIFIERS or in APPEND TXT.
Usually, to finish the group you need a leader line to connect it to the feature.
6. Press **TEXT 1**.
7. Pick LEADER and complete the command as described in [Drawing Leaders and Terminators on page 333](#).

The next sections show how to use the symbol commands and illustrate each symbol. Examples are given at the end of this section to illustrate the sequence of steps.

Setting the Symbol Type

This section shows how to set the type of geometric symbols produced.

[Figure 186. Position Geometric Symbol on page 349](#) shows an example of the Position geometric symbol. Both the Normal and Composite options are shown.

Figure 186. Position Geometric Symbol

Normal 

Composite 

To set the symbol type:

1. Press **SYMBOLS 1**.
2. Pick Normal or Composite.









Drawing a Symbols

Form Symbol

This section shows how to draw the four form symbols. Use the TYPE command to set the symbol normal or composite.

[Figure 187. Symbol Type and Form Geometric Symbols on page 350](#) shows the four form options.

Figure 187. Symbol Type and Form Geometric Symbols

①	②	③	④
			
			

- 1 Straight
- 2 Flat
- 3 Round
- 4 Cylinder

To draw a form symbol:

1. Press **SYMBOLS 1**.
2. Pick the required option in FORM.
3. Indicate the symbol position.

Creo Elements/Direct Drafting will now draw the symbol.

Profile Symbol

This section shows how to draw the two profile symbols. Use the TYPE command to set the symbol normal or composite.

Figure 188. Profile Geometric Symbols on page 350 shows the two PROFILE options.

Figure 188. Profile Geometric Symbols

Line 

Surface 

To draw a profile symbol:

1. Press **SYMBOLS 1**.
2. Pick the required option in PROFILE.
3. Indicate the symbol position.



Creo Elements/Direct Drafting will now draw the symbol.

Location Symbol

This section shows how to draw the location symbols. Use the TYPE command to set the symbol normal or composite.

[Figure 189. Location Geometric Symbol on page 351](#) shows the LOCATION symbols.

Figure 189. Location Geometric Symbol

①	②	③
		

- 1 Position
- 2 Symmetry
- 3 Concentric

To draw a location symbol:

1. Press **SYMBOLS 1**.
2. Pick the required option in LOCATION.
3. Indicate the symbol position.



Creo Elements/Direct Drafting will now draw the symbol.

Alignment Symbols

This section shows how to draw the alignment symbols. Use the TYPE command to set the symbol normal or composite.

[Figure 190. Alignment Geometric Symbols on page 351](#) shows the three ALIGNMENT symbols.

Figure 190. Alignment Geometric Symbols

①	②	③
		

- 1 Angular
- 2 Perpendic
- 3 Parallel

To draw an alignment symbol:

1. Press **SYMBOLS 1**.
2. Pick the required option in ALIGNMENT.

3. Indicate the symbol position.

Creo Elements/Direct Drafting will now draw the symbol.

Runout Symbols

This section shows how to draw the runout symbols. Use the TYPE command to set the symbol normal or composite.

[Figure 191. Runout Geometric Symbols on page 352](#) shows the RUNOUT symbols.

Figure 191. Runout Geometric Symbols

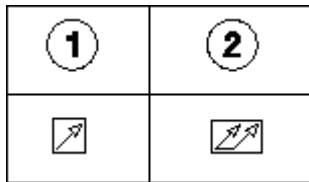

- 1 Circular
- 2 Total

To draw a runout symbol:

1. Press **SYMBOLS 1**.
2. Pick the required option in RUNOUT.
3. Indicate the symbol position.

Creo Elements/Direct Drafting will now draw the symbol.

Appending Text

Text can be added to symbols with the APPEND TXT command. Use this command to interrupt the symbol group, add text, and then proceed with the symbols. The two examples in [Symbol Examples on page 354](#) show you the correct sequence of steps.

Figure 192. Symbol Text

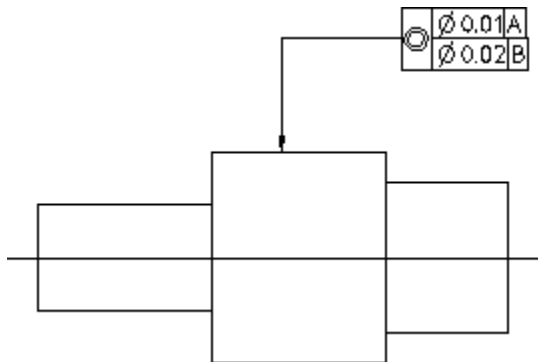

Drawing Modifiers

This section shows how to draw the five commonly used modifying symbols.

[Figure 193. Modifier Geometric Symbols on page 353](#) shows the five MODIFIERS options.

Figure 193. Modifier Geometric Symbols

Diameter		
M		At Maximum Material Condition
L		At Least Material Condition
S		Regardless of Feature Size
P		Projected Tolerance Zone

To draw a modifier:

1. Press **SYMBOLS 1**.
Creo Elements/Direct Drafting displays a menu showing the five modifiers.
2. Pick the required option in the Modifiers menu.
3. Indicate the modifier location.
Creo Elements/Direct Drafting will draw the symbol.

Drawing Target and Revision Symbols

This section shows how to draw the target and revision symbols.

Figure 194. Target and Revision Symbols on page 354 shows the two TARGET symbols and the REVISION symbol.

Figure 194. Target and Revision Symbols

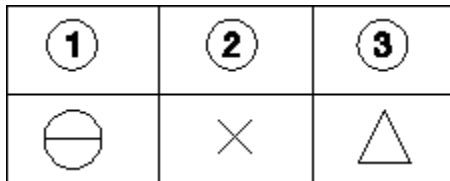

- 1 Symbol
- 2 Point
- 3 Revision

To draw a target symbol:

1. Press **SYMBOLS 1**.
2. Pick required option in TARGET.
3. Indicate the target location.

Creo Elements/Direct Drafting will draw the symbol.

Symbol Examples

Drawing symbols is a simple task and can quickly be mastered by following specified steps.

Before starting, set the text size to 5 mm, the text adjust to 1 (refer to [Adding Text to a Drawing on page 322](#) for details).

Example 1: Single Line Symbol Group

Figure 195. Symbol Group — Example 1

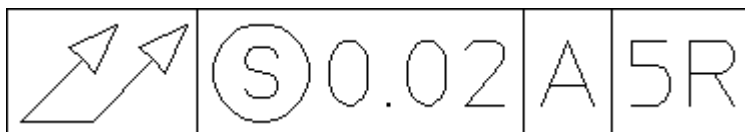

To add symbol text:

1. Pick **Normal** in **TYPE**.
2. Pick **Total** in **RUNOUT**.
3. Pick the (S) in **MODIFIERS**.
4. Pick **APPEND TXT** and enter '0.02'

5. Pick ' | '
6. Pick **APPEND TXT** and enter ' A '
7. Pick ' | '
8. Pick **APPEND TXT** and enter ' 5R '
9. Pick **End Frame**
10. Indicate a point on the drawing.

Example 2: Multiline Symbol Group

Figure 196. Symbol Group — Example 2

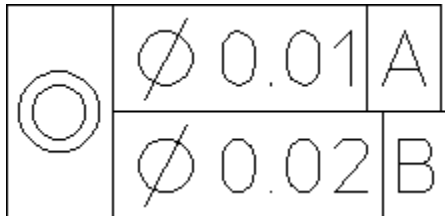

To add symbol text:

1. Pick **Composite** in **TYPE**.
2. Pick **Concentric** in **LOCATION**.
3. Pick the \emptyset icon in **MODIFIERS**.
4. Pick **APPEND TXT** and enter ' 0 . 01 '
5. Pick ' | '
6. Pick **APPEND TXT** and enter ' A '
7. Pick **New Line**
8. Pick the \emptyset icon in **MODIFIERS**
9. Pick **APPEND TXT** and enter ' 0 . 02 '
10. Pick ' | '
11. Pick **APPEND TXT** and enter ' B '
12. Pick **End Frame**
13. Indicate a point on the drawing.

Example 3: Editing a Symbol Group

Symbol groups can be edited using the **EDIT CONV** command. This command converts the symbol into a readable text-string and displays it in normal screen-mode. This text-string also contains control characters ($\backslash 030$) that should not be edited. If they are modified, the conversion link back to the symbols font is lost and the symbol appears as normal text.

To edit the symbol text:

1. Pick the **EDIT CONV**
2. Pick the symbol text

Creo Elements/Direct Drafting displays the text in screen mode, similar to the following:

```
\030\151e0.01|A}  
\030fe0.02|B}
```

3. Edit the text and press [Ctrl] [D] to save your changes.

 **Note**

Use the fontlist for special characters created by FONT EDITOR.

Further Information

For further technical information about symbols, refer to the Creo Elements/Direct Drafting help system:

Enter `help symbol-part` at the Creo Elements/Direct Drafting command line.

The screen will clear and Creo Elements/Direct Drafting will display further information about symbols.

Surface Symbols

 **Note**

The Surface Symbols and Welding Symbols menus are available in the Classical User Interface of Creo Elements/Direct Drafting only. To run Creo Elements/Direct Drafting with this user interface, set `MEPELOOK` to 1 in the `drafting startup` file.

To display the Surface Symbols menu, click Menu 2 in the SYMBOLS menu.

Symbol Set



Click this icon to load or save a symbol set.

Symbols







Click this icon to handle (e.g. load, save or delete) individual symbols in the current symbol set.

Positioning

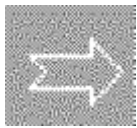

Click this icon to display the positioning menu for the current symbols.

Option	Description
	The symbol is drawn horizontally from the positioning point to the right.
	The symbol is drawn vertically upwards from the positioning point.
	The symbol is drawn vertically downwards from the positioning point.
	The symbol is drawn from the positioning point (first point) towards the second point.
	The symbol is drawn from the positioning point (first point) at the specified angle.

Note

The positioning point marks the foot point of the symbol.

Modifying



Click this icon to remove, read or replace existing symbols in the drawing.

Setting Up Surface Symbols



Click this icon to display the setup menus for surface symbols.

Surface Symbols

Menu Item	Description
File	Filename of the currently loaded symbol set or, following changes, the name of the symbol set to be loaded.
Font	Click Font to display a submenu for selecting the font size for surface symbols. If you prefer to use your own font size, specify the applicable number.
Color	Click Color to display a submenu for selecting the color for surface symbols. Optionally, you can select RGB values.
Text Angle	Click Text Angle and then specify the text character slant angle.

Reference Lines

Menu Item	Description
Color	Click Color to display a submenu for selecting the color for reference lines. Optionally, you can select RGB values.
Width	Click Width to display a submenu for selecting the reference line width. Optionally, you can specify a numerical value for the reference line width.  Note The Width applies to both reference lines and symbols.
Automatic	Click Automatic if you want reference lines to be added automatically (YES) or not (NO)

Reference Line Terminator





Menu Item	Description
Shape	Click Shape in Ref. Line Terminator to select a dot, an arrow, a triangle or a slash as the terminator for reference lines.
Size	Click Size in Ref. Line Terminator to display a submenu from which you can select the reference line terminator size. Optionally, you can specify a numerical value for this size.

Angle Correction

Menu Item	Description
Angle Correction	Click Angle Correction. Then specify the maximum deviation angle (in degrees) at which the reference line will still snap to the horizontal or vertical direction. The default value of 45 degrees implies that the reference line is always drawn horizontally or vertically. If you want to draw reference lines at arbitrary angles, set the Angle Correction to 0

The "surf_sym" Symbol Set Supplied with Creo Elements/Direct Drafting

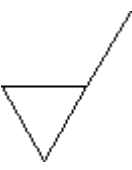
The surf_sym symbol set supplied with Creo Elements/Direct Drafting includes the following preconfigured surface symbols:

- coated 
- milled 
- mat_remov 
- no_mat_remov 

- smooth
 - Ra 1.6 / Rz 2.5 / *geschliffen*
 - Ra 6.3
 - Ra 1.6
- raw

Use Load to load this symbol set.

Illustrated Examples of Surface Symbols

To create your own surface symbols, either modify one of the preconfigured symbols supplied with Creo Elements/Direct Drafting or create symbols "from scratch". Both methods are illustrated in the following section.

In the following example, four surface symbols are added to the drawing of a casting.

Figure 203. Casting plus Surface Symbols

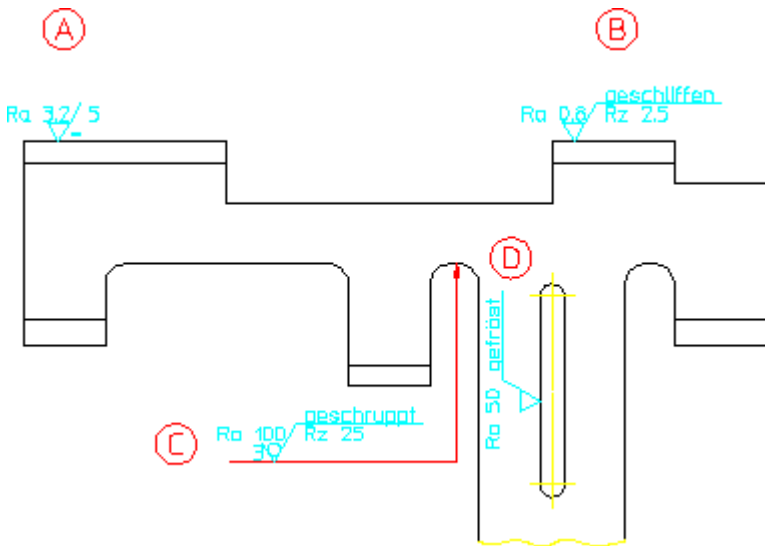

The following exercise illustrated the procedure for creating the surface symbols ((A)), ((B)), ((C)) and ((D)). This exercise assumes that the Surface Symbols menu is displayed.

Symbol ((A))

Proceed as follows:

1. Click S in the first column of the Compose menu to display the current symbol definitions. Then click the following symbol shape icon:



 **Note**

The extension line running to the right is drawn only if you specify additional symbol-related data.

2. Click a2 in the first column of the Compose menu. Then click Ra 3.2 in the associated submenu.
3. Click c in the first column of the Compose menu. Then click 5 in the associated submenu.
4. Click d in the first column of the Compose menu. Then click = in the associated submenu.
5. Click the following icon:



You do not need to specify any positioning options because you want to draw the symbol in the default direction (from left to right).

6. Specify the positioning point (the foot point) for symbol ((A)) in your drawing.

Symbol ((B))

Proceed as follows:

1. Load the smooth surface symbol.
2. Set d to BLANK.
3. Set a2 to Ra 0,8.
4. Remove the entry for c by specifying a blank in apostrophes: ''
5. Specify Rz 2, 5 (in apostrophes) for fl.
6. Position symbol ((B)) in your drawing.

Symbol ((C))

Proceed as follows:

1. Click the following icon:



 **Note**

When you select a different symbol type, the existing settings are preserved in the Compose menu. Therefore, any settings for a different symbol type require explicit changes. To leave any symbol element blank, you either specify a space character (in apostrophes) or you click BLANK.

2. Set `d` to BLANK.
3. Specify `Ra 100` for `a2`.
4. Specify `grind` for `b`.
5. Set `e` to 3.
6. Set `f1` to `Rz 25`.
7. Position the symbol at a suitable point to the left of and below the area to marked for grinding.
8. To select the begin point of the reference line, click on a point to the left of the symbol foot point.
9. To select the flexion point of the reference line, click on a point close to a line perpendicular to the area to be marked for grinding.
10. To select the begin point of the reference line arrow, click on a point on the area to be marked for grinding.
11. Click CONFIRM.

Symbol ((D))

Proceed as follows:

1. Load the `milled` surface symbol.
2. Set `a1` to `Ra 50`.
3. Click on the "vertically upwards" positioning arrow icon to position symbol ((D)) in your drawing.

Welding Symbols

Note

The Surface Symbols and Welding Symbols menus are available in the Classical User Interface of Creo Elements/Direct Drafting only. To run Creo Elements/Direct Drafting with this user interface, set MEPELOOK to 1 in the me10 startup file.

To display the Welding Symbols menu, click Menu 3 in the SYMBOLS menu.

Composing a Welding Symbol

To compose a welding symbol, click on the applicable field(s) in the first column of the Compose menu or select the associated items of the symbol (indicated graphically in the menu).

Note

To familiarize yourself with the symbol composition method, load one of the welding symbols supplied with Creo Elements/Direct Drafting and check the resulting welding symbol in your drawing with its associated items in the Compose menu.

Text

Click Text in the Welding Symbols menu to display the associated Text menu. You can specify the individual text strings for your welding symbols either as default strings in submenus, or you can specify text strings (in apostrophes).

Please note that the following applies to fillet weld offsets:

- Specify the following if you want the Z to cross the reference line:
 \∇
- If you do not want the Z to cross the reference line, specify the following:
 \∇

Symbol Elements

The following welding symbol elements are provided to facilitate the creation of welding symbols:

Item	Description
Sy 1	Welding symbol
Sy 2	Welding symbol
Sy 3	Welding symbol
Sy 4	Supplementary symbol
Sy 5	Supplementary symbol
Ring	Ring weld ("weld all around")
Assembly	Assembly weld
Fork	Fork
--	<p>Relative position of the reference extension line. The following options are available:</p> <ul style="list-style-type: none"> • <code>above</code>: the reference extension line is located above the reference line. • <code>below</code>: the reference extension line is located below the reference line. • <code>none</code>: no reference extension line.

Positioning Welding Symbols

Proceed as follows to position a welding symbol:

1. Click the following icon:



2. Select the applicable positioning option.

Note

Unless you explicitly select a positioning option, the symbol will be drawn from left to right. This default is associated with the following icon:

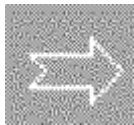

3. Click a point in your drawing where you want to add the welding symbol.
4. Draw the reference line for your welding symbol. Follow the instructions in the following section.

Menu 2

Menu 2 for welding symbols provides a number of functions similar to those for surface symbols plus a number of welding-related functions.

Welds



This icon selects fillet weld symbols.

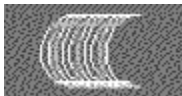

Use this function to indicated weld surfaces in your drawing.

Text Functions

Use the functions of this menu section to add text in the font size of the current drawing. Click the applicable icon and then enter the text (in apostrophes) into the user input line.



Adds text without a frame.



Adds text in a rectangular box.



Adds text in a balloon.



Enables you to move text added by one of these three text frame options.

Reference Line

This function enables you to manually create a reference line for the current symbol.

The reference line always runs from the object to the symbol. Proceed as follows:

1. Click the following icon in Menu 2:



1. The begin point of the reference line is automatically attached to the symbol. Click any points along the reference line as well as any bend points.
2. Click the end point of the reference line.
3. To complete the reference line, either:
 - Double-click on its end point, or
 - Click CONFIRM.

 **Note**

If you want to break (interrupt) the reference line, click Free.

The Back option enables you to delete the last point on the reference line.

Stretching Symbols

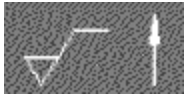

Stretches symbols vertically.

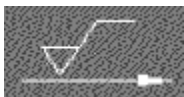

Stretches symbols horizontally.

Construction Lines

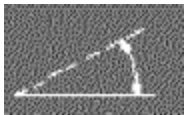

Creates a construction line at an angle.

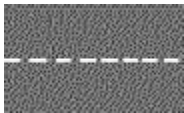

Creates a horizontal construction line.



Creates a vertical construction line.

Setting Up Welding Symbols

The text, color, and reference line Setup options for welding symbols are similar to those for surface symbols. See [Setting Up Surface Symbols on page 346](#).

Weld

Menu Item	Description
Color	Click Color to display a submenu from which you can select the color of fillet weld and weld surface symbols. Optionally, you can specify RGB values.
Hatch Dist	Click Hatch Dist to display a submenu from which you can select the hatch distance for fillet weld symbols. If you want to draw fillet weld symbols "filled", set this distance to 0.
Linetype	Linetype for fillet welds and weld surfaces.

The "weld_sym" Symbol Set Supplied with Creo Elements/Direct Drafting

The weld_sym symbol set supplied with Creo Elements/Direct Drafting includes the following preconfigured welding symbols:

- 

• V-U-weld
- 

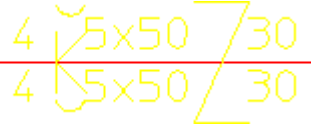
• V_back
- 

• fillet_back
- 

• fillet_ring

Use Load to load this symbol set.

Illustrated Examples of Welding Symbols

To create your own symbols, either modify one of the preconfigured symbols supplied with Creo Elements/Direct Drafting or create symbols "from scratch". Both methods are illustrated in the following section.

In the following example, a number of welding symbols are added to a simple sheet metal design.

Figure 208. Sheet Metal Design plus Welding Symbols

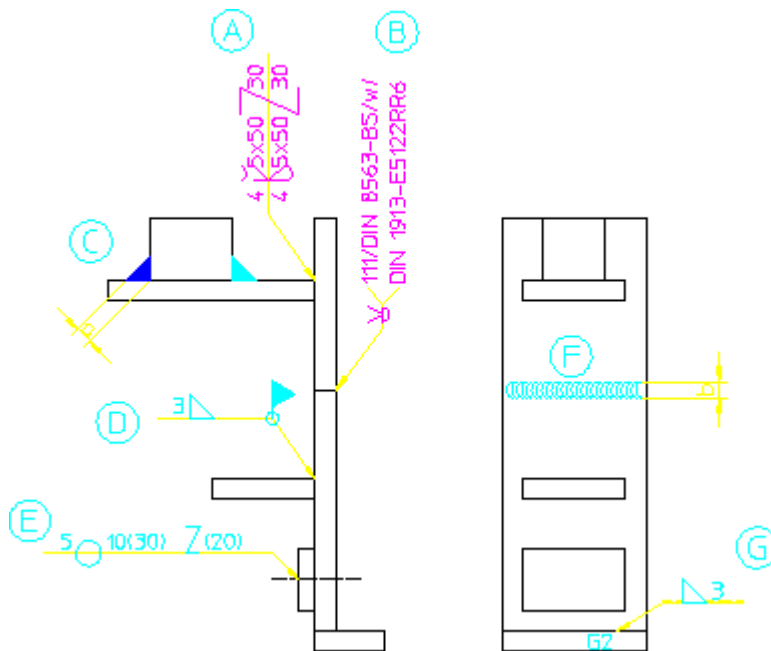

The following exercise illustrated the procedure for creating the welding symbols ((A)), ((B)), ((C)), ((D)), ((E)), ((F)) and ((G)). This exercise assumes that the Welding Symbols menu is displayed.

Symbol ((A))

Proceed as follows:

1. Load the `fillet_back` welding symbol.
2. Click the following icon:



3. Click the following positioning icon:



4. Click the positioning point for the symbol.
5. Click a point vertically above the symbol positioning point.
6. Click the reference line end point.

Symbol ((B))

1. Load the ∇ _back welding symbol.
2. Position this welding symbol and its reference line in your drawing.

Symbol ((C))

1. In the SETUP menu for welding symbols, set the hatch distance to 0.
2. Display Menu 2 for welding symbols.
3. Click the following icon:



4. Specify the fillet weld width: 4
5. Click the vertex for the "left" leg of the fillet weld.
6. Click the first leg.
7. Click the second leg.
8. Repeat these four steps to define the "right" fillet weld.

Symbol ((D))

1. Specify 3 for T1.

Set Sy 2 to:

delta

2. Set R.nt to:



3. Set M.nt to:



4. Position this symbol and its reference line.

 **Note**

The SETUP menu enables you to select defaults for the size of the symbol elements.

Symbol ((E))

1. Load the `fillet_ring` welding symbol.
2. Click Text.
3. Replace the entry for T 1 by: 5
4. Replace the entry for T 2 by:
10 (30) \v (20)
5. Click the following positioning icon:



6. Click the positioning points for the symbol.
7. To define the reference line direction, click on a point horizontally above and to the left of the symbol positioning points.
8. Click the reference line end point.

Symbol ((F))

1. Click Menu 2 in Welding Symbols.
2. Click the following icon:

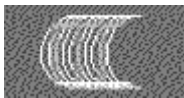

3. Click the begin point of the weld.
4. Specify the weld contour width: 5
5. Specify a weld contour spacing factor: 4
6. Click the end point of the weld.

Symbol ((G))

1. Specify 3 for T1.
2. Set Sy 2 to:
delta
3. Set - - to above.
4. Position the symbol such that its reference line runs to the left.

Grouping

You can group annotations together. [Groups on page 534](#) may consists of a single dimension, multiple text elements and multiple symbols.

12

Handling Parts and Assemblies

Introduction to Parts	375
Parts Structure Explained	375
Creating an Assembly Drawing.....	378
Deleting Parts	382
Modifying Parts	383
Editing Parts	384
Initiating a New Empty Part	385
Making the Parent Part Active	386
Creating Parts	386
Gathering Elements Into Other Parts.....	389
Gathering Dimensions into Other Parts	391
Gathering Parts	392
Showing Parts.....	395
Smashing Subparts	396
Sharing Parts	398
Unsharing Parts	400
Working with the Parts Editor	401
Producing a Parts List.....	403
Viewing Parts	406
Spotlighting Parts	407
Changing Parts into Symbols	407
Setting the Part Reference Point.....	408
Renaming Parts	408
Multiple Drawing Scales.....	409
Scaling Parts about a Reference Point	411
Unique Partnames.....	411
Further Information	412

This chapter shows how to use parts in your drawing.

PARTS commands duplicated are listed in [Table 9. PARTS Commands Used By Other Modules on page 373](#).

Table 9. PARTS Commands Used By Other Modules

Block	Calls the Option
INIT	Initiate Part (refer to "Initiating a New Empty Part")
END	End (refer to "Making the Parent Part Active")
EDIT	Edit Part (refer to "Editing Parts")
SMASH	Smash Subpart (refer to "Smashing Subparts")
GATHER	Gather Element (refer to "Gathering Elements into Other Parts")
RENAME	Rename (refer to "Renaming Parts")

Press the **PARTS 1** block. The screen menu appears containing the following commands:

- EDIT
- INITIATE
- END
- CREATE
- GATHER EL (Gather Element)
- GATHER DIM (Gather Dimension)
- GATHER PRT (Gather Part)
- SHOW
- SMASH SUBP (Smash Subpart)
- SHARE
- UNSHARE
- PRT EDITOR
- OPTIONS

Press **PARTS 2**, a second menu (**PARTS 2**) appears containing the less frequently used commands. You can also call up this menu from the **PARTS 1** menu by picking MENU 2.

PARTS 2 contains the following commands:

- VIEW
- SPOTLIGHT
- SYMBOL

-
- SET REF PT (Set Reference Point)
 - RENAME
 - PART SCALE
 - SCALE REF
 - PART LIST
 - OPTIONS

Introduction to Parts

Parts are most useful in large complex drawings. Therefore, in your first few weeks using Creo Elements/Direct Drafting you may not want to complicate the drawing process by using parts. However, as you become a proficient user, you will begin to see how the use of parts will simplify complex drawings and increase your productivity. Using parts in a drawing is a matter of personal choice; different users will use a different parts structure on the same drawing.

With these points in mind, now consider some ideas and definitions of parts.

What is a Part?

A part is a logical grouping of elements, for example, a group of elements that make up a component in a sub-assembly.

A drawing created without the use of parts consists of a number of lines, circles, arcs, pieces of text, and so on. Each line, circle, arc, and so on, is known as an element.

If you use parts in a drawing, each part is a collection of elements. Thus, without parts, a drawing consists of a collection of elements, but with parts a drawing consists of several parts, each part being a collection of elements.

The Top Part

Remember that without parts a drawing is a collection of elements. You could also say that a drawing without parts is in effect a drawing containing one part; the part and the drawing are one and the same. Each part has a name (more details are given later in this section), and the name of the part you are using is displayed in the System Status Line. In a drawing without parts you will see the name associated with the top part (default name `TOP`) displayed in the System Status Line; all the elements of the drawing are in this single part.

In an assembly drawing certain parts will contain drawing elements, a name, and possible subparts. Other parts contain only a name and possible subparts, these parts are used as pointers to assemblies.

Parts Structure Explained

A parts structure can be thought of as a family tree showing the hierarchical relationships of all the parts. Because of this hierarchical nature, we talk about the different levels of the structure. At the highest level a single part exists; this is the `TOP` part already discussed. For your first few drawings using parts, it is best to use a parts structure with only one level; more experienced users will use a multilevel structure. The two types of parts structure are shown below:

Figure 209. One Level Parts Structure

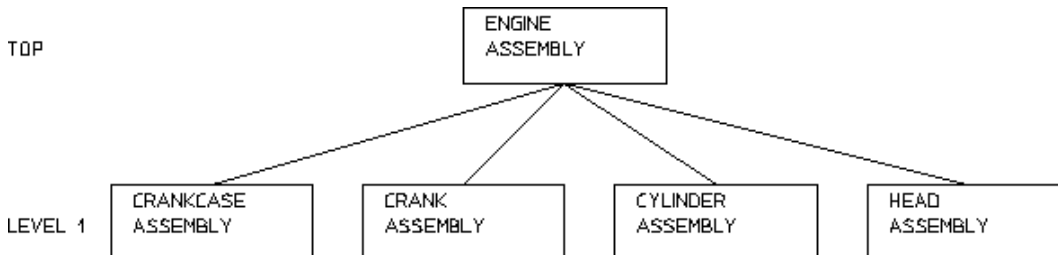
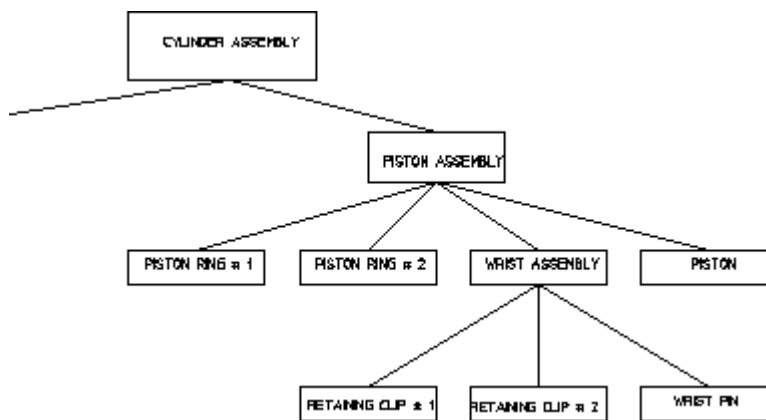

Figure 210. Multilevel Parts Structure



Hierarchical Parts Structure

The hierarchical structure of parts means that one part can own other parts. Refer to the CYLINDER ASSEMBLY hierarchy shown in [Figure 210. Multilevel Parts Structure on page 376](#). The parts structure is as follows:

PISTON ASSEMBLY can be thought of as the owner of PISTON, PISTON RING # 1, PISTON RING # 2, and WRIST ASSEMBLY.

We refer to the owning part (PISTON ASSEMBLY) as the parent and the owned parts (PISTON, PISTON RING # 1, PISTON RING # 2, and WRIST ASSEMBLY) as subparts. (Refer to parent/child relationships in the manual *Setting Up and Using the HP-DMS Applications*.)

Note

This ownership mechanism implies that deleting a parent part will also result in the deletion of all its subparts.

Setting the Active Part

Except for a few special cases, all newly created elements (lines, arcs, text, and so on) are placed in the active part. Also, most of the commands using the **SELECTION** block (for example DELETE, CHANGE) only operate on the active part. The EDIT command allows you to set which part is active. Thus by using the EDIT command to make different parts active you can place elements in different parts.

Note

The name of the active part is displayed in the System Status Line.

Rules for Part Names

Follow these rules when entering part names:

- Part names are limited to 255 characters in length.
- Any characters may be used in a part name with the exception of:
 - / (Only allowed as the name of the top part when not used together with other characters.)
 - ~
 - . (Invalid part name when used alone, but may be used together with other characters.)

Examples of invalid names are:

- .
- ..
- /hello
- hello~

Examples of possible names are:

- hello
- / (Can be used only for the top part.)

Whenever possible, give your parts meaningful names. This will help recognize the part.

 **Note**

Creo Elements/Direct Drafting can assign a default name to a part. The Creo Elements/Direct Drafting default name will be in the series .1, .2, .3 and so on. See [Initiating a Part on page 385](#).

The Advantages of Parts

Using parts has the following advantages:

- You can arrange a complex drawing into a convenient logical structure.
- **MODIFY**, **DELETE** and most of the commands using the **SELECTION** block can be used on complete parts, thus you need only identify the part and not every element.
- Parts can be stored in or loaded from a file. This allows you to build up libraries of standard parts.
- By making a master drawing into parts, two or more people can work on individual parts of the master drawing. You can also quickly build up a final master drawing.
- Using special PARTS commands, such as SYMBOL allows you to create custom symbols.

Creating an Assembly Drawing

To make full use of the Creo Elements/Direct Drafting parts functionality you should create and maintain a parts and assemblies structure for your drawing files.

This approach to drawing facilitates the link between your Creo Elements/Direct Drafting design data and a relational database management system such as HP-DMS.

The following example shows one way to create the assembly drawing WRIST ASSEMBLY from the following component drawings:

- RETAINING CLIP # 1
- RETAINING CLIP #2
- WRIST PIN

[Figure 211 WRIST ASSEMBLY Structure on page 379](#) shows the WRIST ASSEMBLY structure.

Figure 211 WRIST ASSEMBLY Structure

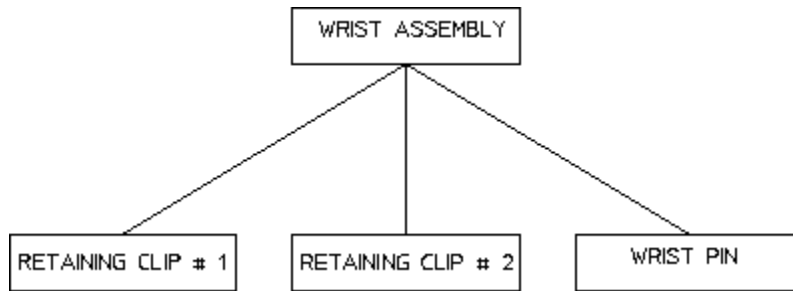

Initial Stages

For the purposes of this example, assume that each component drawing has not yet been given a part name.

Note

Drawings have two names associated with them:

1. The drawing storefile name — given here in lowercase.
 2. The drawing partname — given here CAPITALIZED.
-

First load each individual component drawing, give it a part name and set a reference point to enable accurate positioning in the final assembly drawing.

Load the drawing file `retain_clip1_d`.

1. Press **FILE**.
2. Pick **Drw/Part** in **LOAD** (or use the **FBROWSER** command).
3. Enter `retain_clip1_d`.

Creo Elements/Direct Drafting displays the drawing of **RETAINING CLIP #1**.

You must now set a reference point on the drawing to enable accurate positioning in the final assembly drawing.

4. Pick **SET REF PT** in **PARTS 2**.
5. Indicate a reference point.

Delete all construction lines.

6. Press **DELETE, C-GEO, ALL**.

Store the new drawing (without construction lines).

7. Press **FILE**.

-
8. Pick **Part** in **STORE ▶ MI**.
 9. Enter the part name `RETAINING CLIP # 1`.
 10. Enter the new storefile name (for example `retainclip1`).
 11. Press **DELETE, ALL, CONFIRM**.
 12. Repeat steps 1 to 14 for the component drawings:
 - `retain_clip2_d`.
 - `wrist_pin_d`.

Creating WRIST ASSEMBLY

Next create the assembly drawing `WRIST ASSEMBLY`:

1. Press **PARTS 2**.
2. Pick **On** in **SPOTLIGHT** (this command causes the active part to have a normal appearance and all non-active parts to be shown in magenta dotted lines).

Make sure that the Creo Elements/Direct Drafting top part is empty.
3. Press **MENU 1**.
4. Pick **Top** in **EDIT**.
5. Press **DELETE, ALL, CONFIRM**.

Rename the top part with the assembly drawing name you wish to see in the parts list.
6. Pick **RENAME** in **PARTS 2**.

Creo Elements/Direct Drafting responds by asking for the new name of the active part.
7. Enter `WRIST ASSEMBLY`.

The name of the active part in the status line changes to `WRIST ASSEMBLY`. Note, this part contains only the assembly name `WRIST ASSEMBLY` but no drawing elements.

Now load the first part of the assembly, for example the wrist pin.
8. Press **FILE**.
9. Pick **Subpart** in **LOAD**.

Creo Elements/Direct Drafting asks for the filename of the drawing to be loaded.
10. Enter the drawing name, `wristpin`.

Creo Elements/Direct Drafting asks you to indicate a reference point to position the drawing.

-
11. Indicate a reference point.
 12. Repeat steps 4 to 7 for the drawings:
 - retainclip1
 - retainclip2
 13. Store the final assembly drawing as `wrist_assy`.

Examining the Parts Tree

Now take a look at the parts tree.

1. Press **PARTS 2**.
2. Pick **Tree** in **PART LIST**.
3. Pick **Screen** in **OPTIONS**.

Creo Elements/Direct Drafting responds by clearing the screen and displaying the parts tree:

```
[*] WRIST ASSEMBLY [~1] [1:1]
    RETAINING CLIP # 1 [~4] [1:1]
    RETAINING CLIP # 2 [~3] [1:1]
    WRIST PIN [~2] [1:1]
```

Creating Further Assemblies

The next stage in your assembly would be to create the `PISTON ASSEMBLY` drawing. The procedure is the same as previously described:

1. Create an empty top part in Creo Elements/Direct Drafting.
2. Rename the top part `PISTON ASSEMBLY`.
3. Construct `PISTON ASSEMBLY` from the following parts:
 - `PISTON RING # 1` — a single component part.
 - `PISTON RING # 2` — a single component part.
 - `WRIST ASSEMBLY` — an assembly.
 - `PISTON` — a single component part.

Creating a Final Engine Assembly Drawing

The ultimate industrial requirement would normally involve the creation of several assembly and sub-assembly drawings. In the case of our example the following drawings would be incorporated into a final assembly drawing at the highest level of detail, for example `ENGINE ASSEMBLY`:

- `CRANKCASE ASSEMBLY`

- CRANK ASSEMBLY
- HEAD ASSEMBLY
- CYLINDER ASSEMBLY (which contains the PISTON and WRIST assemblies)

Figure 212. Completed Cylinder Assembly Drawing on page 382 shows how the completed cylinder assembly drawing might appear:

Figure 212. Completed Cylinder Assembly Drawing

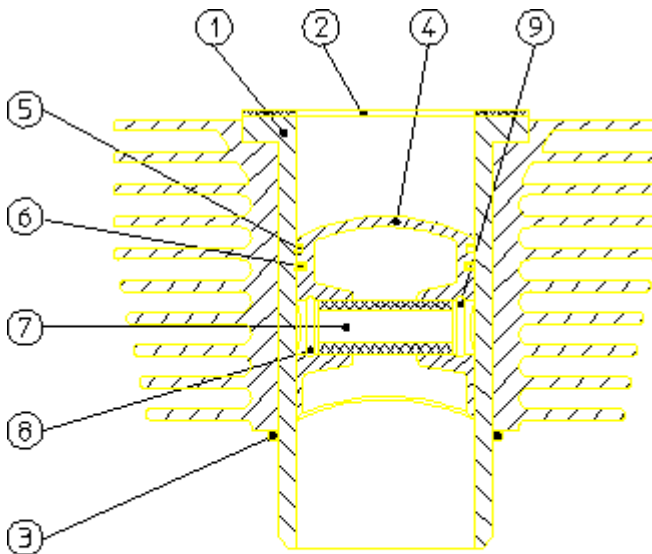

1	CYLINDER	6	PISTON RING #2
2	GASKET	7	WRIST PIN
3	BOTTOM 'O' RING	8	RETAIN CLIP #1
4	PISTON	9	RETAIN CLIP #2
5	PISTON RING #1		

Deleting Parts

Consider the CYLINDER ASSEMBLY hierarchy with PISTON ASSEMBLY active. Figure 213. Deleting Parts on page 383 shows three examples of the deletion mechanism. The star shows the active part; the D shows that an element in the part was identified for deletion.

Figure 213. Deleting Parts

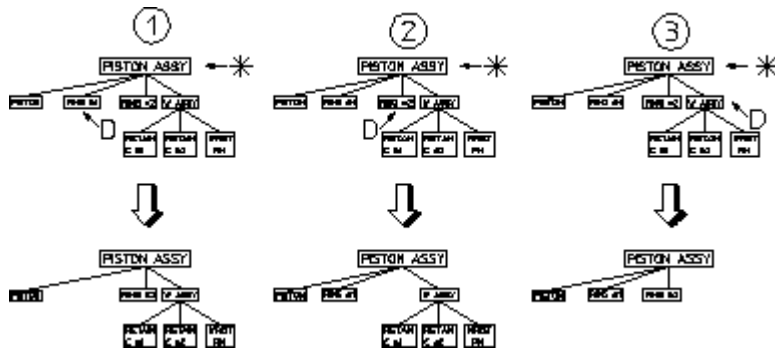

Note that in the third case:

- The entire WRIST ASSEMBLY would be deleted if any element of RETAIN CLIP 1, RETAIN CLIP 2, or WRIST PIN were identified.
- If WRIST ASSEMBLY was made active and an element in RETAIN CLIP # 1 identified for deletion, only RETAIN CLIP # 1 would be deleted.

Note

You cannot delete the current active part or the Top part. A link is always maintained to the Top part.

To delete parts:

1. Press **PARTS 1**.
2. Pick Part in EDIT.
3. Identify the appropriate part in your hierarchy you wish to set as active. Note that selection of the active part will control what is actually deleted.
4. Press **DELETE**.
5. Identify the part(s) you wish to delete.

Modifying Parts

Use the **MODIFY** menu to modify your parts.

Consider the CYLINDER ASSEMBLY hierarchy again. Suppose you wish to move the entire piston assembly, that is the piston, rings, wrist pin, and so on. The simplest way to identify all these is to first set a part above PISTON ASSEMBLY active, in this case CYLINDER ASSEMBLY:

1. Press **PARTS 1**.
2. Pick Part in EDIT.

-
3. Identify the CYLINDER ASSEMBLY.

With CYLINDER ASSEMBLY active, you only have to identify an element in PISTON ASSEMBLY. Creo Elements/Direct Drafting will accept the assembly and all its subparts.

4. Complete the required move commands in **MODIFY**.

 **Note**

To modify parts or elements above the active part you must press GLOBAL in SELECTION.

Editing Parts

This section shows how to set a part as active so that you can then change it. All new drawing elements created from then on belong to the active part.

Similarly, whichever part is active affects the results of the **MODIFY** and **DELETE** commands. If you have the SPOTLIGHT turned on (refer to [Spotlighting Parts on page 407](#)), the active part is shown in normal linetypes and colors, while all other parts are shown in magenta dotted lines. The name of the active part is displayed in the System Status Line.

The three EDIT options are:

- Part
- Top
- Parent

Editing a Part

This is the default option.

To edit a part (make a part active):

1. Press **PARTS 1**.
2. Pick **Part** in **EDIT**.

Creo Elements/Direct Drafting will prompt for the name of a part.

3. Enter the name of a part, or identify an element of the part in any viewport.

Creo Elements/Direct Drafting then sets the named, or identified, part as the active part.

Editing Top

To edit the top part (set the highest part of the parts structure as the active part):

1. Press **PARTS 1**.
2. Pick **Top** in **EDIT**.

Creo Elements/Direct Drafting sets the **Top** part as the active part.

Editing the Parent

You can move the active part status to the parent of the currently active part. In relation to a given part, the parent is always one level higher in the parts structure. To edit the parent part:

1. Press **PARTS 1**.
2. Pick **Parent** in **EDIT**.

Creo Elements/Direct Drafting sets the parent of the currently active part as the active part.

Initiating a New Empty Part

This section shows how to create a new empty part. The active-part status will be altered after the command has been executed so that the new part is active. The **INITIATE** command options are:

- Part
- Subpart

Initiating a Part

This is the default option. Create a new empty part under the **Top** part and set the new part as the active part so you are ready to draw in it.

Note

It is not necessary to make the **Top** part active before you use the **Part** option. Every new part you create is automatically positioned immediately below the **Top** part.

To create a new empty part immediately below **Top**:

1. Press **PARTS 1**.
2. Pick **Part** in **INITIATE**.

-
3. Enter a name for the new part or allow Creo Elements/Direct Drafting to assign a default name.

Creo Elements/Direct Drafting now creates the new empty part below the **TOP** part and sets it as the active part. You can now begin adding drawing lines, text, and so on to the part.

4. Place at least one element (or subpart) in the new part otherwise it will be deleted when you change the active part status.

Initiating a Subpart

You can create a new empty part under the active part and set the new part as the active part so you are ready to draw in it. This means that a subpart can be created below an existing part, or below an existing subpart.

Before picking **Subpart**, make sure you have the correct part active as the new part will belong to it and be one level below.

To create a new empty subpart:

1. Press **PARTS 1**.
2. Pick **Subpart** in **INITIATE**.
3. Enter a name for the new subpart.

Creo Elements/Direct Drafting creates the new empty part and sets it as the active part. You can now begin adding drawing lines, text, and so on, to the part.

Place at least one element in the new part, otherwise it will be deleted when you change the active part status.

Making the Parent Part Active

You can change the active part status to the parent of the part currently active:

1. Press **PARTS 1**.
2. Pick **END**.

Creo Elements/Direct Drafting now sets the parent of the currently active part as the active part.

Creating Parts

This section shows how to make a new part from existing elements in the active part. The active part status will be unaffected after the command has been executed.

The two CREATE options are:

- Subpart
- Detail

Creating a Subpart

This is the default option. You can create a new part by transferring elements from the active part into the newly created one. The new part will be placed below the active part.

Before selecting the command make sure you have the correct part active as the new part will belong to it and be one level below.

To create a subpart:

1. Press **PARTS 1**.
2. Pick **Subpart** in **CREATE**.
3. Enter the name for the new part.

Having entered the part name, begin identifying the elements in the active part you wish to transfer to the new one.

Note

If you incorrectly identify an element for transfer, press UNDO to cancel the transfer.

4. When you have chosen all the elements you require, press **END** (or any other command except **CANCEL**) to finish the command.

Creo Elements/Direct Drafting transfers all the identified elements to the new part.

Creating Detail Drawings

You can create detail drawings in your drawing. Each detail is a magnified copy of an area of the active part.

Note

Dimensions are not affected by the magnifying factor; thus the dimensions on your detail will agree with the part from which it was taken.

Figure 214. Creating a Detail Part on page 388 shows how to create a detail drawing within your main drawing:

Figure 214. Creating a Detail Part

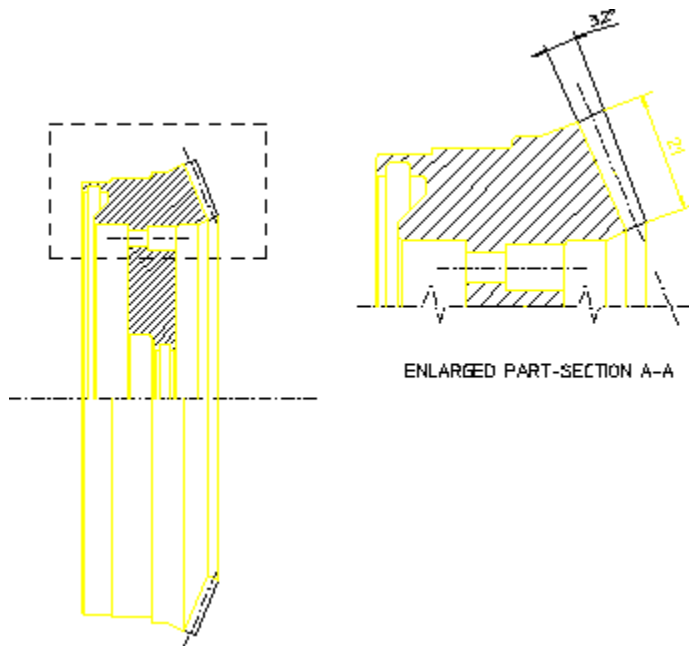

Finish drawing the part to be detailed and make it the active part.

This technique of finishing the part before creating a detail differs from traditional drafting methods. However, using **WINDOW** functions, you can just as easily draw intricate features on the main drawing as on the detail drawing.

The Detail option is used to produce a magnified copy for dimensioning purposes.

To produce a detail drawing:

1. Press **PARTS 1**.
2. Pick **Detail** in **CREATE**.
3. Enter the required magnifying factor for the detail.
4. Box the area of the active part from which you wish to form the detail. The edges of the box will determine where elements are cut, so identify the corners carefully (in the detail drawing the dashed lines indicate where the box was placed).
5. Indicate a reference point for the copy operation, then indicate the desired location for the reference point.

Creo Elements/Direct Drafting now creates the detail part.

Notes on Detail Parts

- The detail part is automatically placed in level 1 of the parts structure (that is, below the `Top` part).
- The detail part is assigned the next default name generated by Creo Elements/Direct Drafting in the sequence . 1, . 2, . 3, and so on. (Note that a postfix `[shared #1] [detail]` is displayed in the parts tree; this is for information only and is not part of the name).
- The detail part will be a unique shared part (refer to [Sharing Parts on page 398](#)). However, it is not shared with the part from which it was detailed. Thus, if you modify the original part, its detail will not be changed automatically.

Note

To dimension a detail part you must make it the active part.

Gathering Elements Into Other Parts

During the drawing process it may prove useful to transfer the ownership of existing elements in one part to the active part. Pick `GATHER EL` to transfer elements.

Note

- If the element to be transferred is the master element of a group, the group is ungrouped before gathering.
 - If the element to be transferred is a normal element of a group, the element is removed from the group before gathering.
-

The two `GATHER EL` options are:

- Delete Old
- Copy

With Delete Old

This is the default option. After using the command, the elements transferred will only exist in the active part.

Note

Take care to identify the correct elements as mistakes can only be rectified by changing the active part and gathering the element back.

Pick On in SPOTLIGHT to see the changes made in your drawing.

To transfer elements from one part to the active part:

1. Press **PARTS 1**.
2. Pick **Delete Old** in **GATHER EL**.
3. Identify the elements (in non-active parts) that you wish to transfer to the active part.

As you identify each element, it is deleted from the original part and it appear in the active part.

With Copy

The elements indicated will be duplicated in the active part.

To copy elements from any part to the active part:

1. Press **PARTS 1**.
2. Pick **On** in **SPOTLIGHT**.
3. Pick **Copy** in **GATHER EL**.
4. Identify an element (in any non-active part) that you wish to copy to the active part.
5. Indicate a reference point for the copy operation.
6. Indicate the desired location for the reference point.

Example

Refer to [Figure 215. Gathering Elements on page 391](#). You have incorrectly added drawing elements to PISTON RING # 1. Pick GATHER EL to transfer these elements to RETAINING CLIP # 1.

Figure 215. Gathering Elements

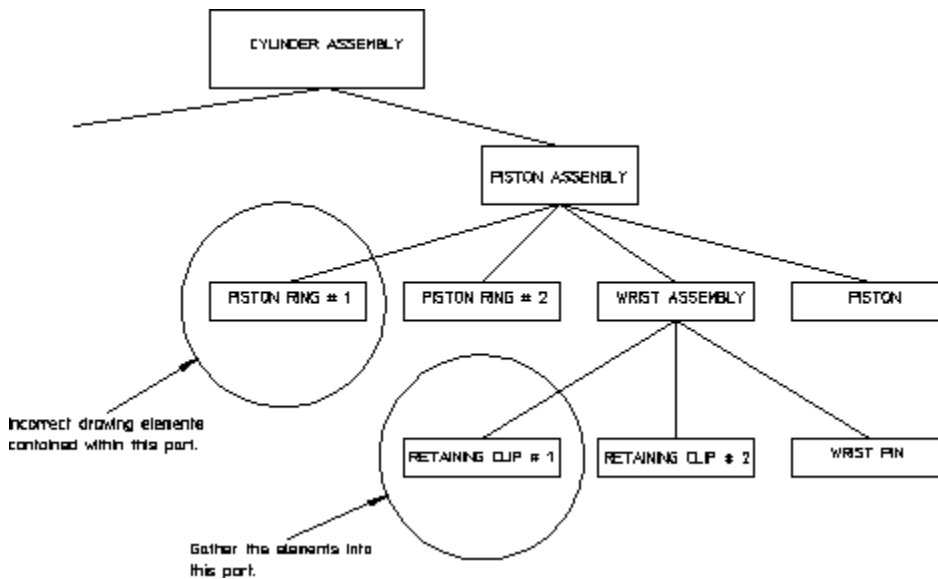

To transfer elements from PISTON RING # 1 to RETAINING CLIP # 1:

1. Press **PARTS 1**.
2. Pick **Part** in **EDIT**.
3. Identify RETAINING CLIP # 1.
Creo Elements/Direct Drafting makes RETAINING CLIP # 1 the active part.
4. Pick Delete Old in GATHER EL.
5. Identify elements in PISTON RING # 1 you wish to transfer to the active part.
As you identify each element it will be deleted from its original part and appear in the active part.

Gathering Dimensions into Other Parts

This section shows how to transfer the ownership of existing dimensions.

To transfer the ownership of a dimension below the active part to the active part:

1. Press **PARTS 1**.
2. Pick **GATHER DIM**.
3. Identify the dimension to be gathered.

Creo Elements/Direct Drafting transfers the ownership of the selected dimension.

 **Note**

You cannot gather a dimension from above the level of the active part in parts hierarchically.

The **GATHER DIM** options are:

- All Below
- All Above

With All Below

To transfer the ownership of all dimensions below the active part to the active part:

1. Press **PARTS 1**.
2. Pick **All Below** in **GATHER DIM**.

Creo Elements/Direct Drafting transfers the ownership of all the dimensions in parts hierarchically that are below the active part to the active part.

With All Above

To transfer the ownership of all dimensions above the active part with reference elements in or below the active part to the active part:

1. Press **PARTS 1**.
2. Pick **All Above** in **GATHER DIM**.

After the operation, all dimensions in parts hierarchically above the active part with reference geometry in or below the active part are owned by the active part.

Gathering Parts

This section shows how to transfer the ownership of existing parts to the active part. The gathered part belongs to the active part and it is placed one level below the active part in the parts structure.

 **Note**

If the part to be transferred is the master element of a group, the group is ungrouped before gathering.

If the part to be transferred is a normal element of a group, the part is removed from the group before gathering.

The two GATHER PRT options are:

- Delete Old
- Copy

With Delete Old

This is the default option.

To transfer the ownership of a part to the active part:

1. Press **PARTS 1**.
2. Pick **Delete Old** in GATHER PRT.
3. Identify the part to be gathered or enter its name. You cannot gather a part from above the level of the active part.

Creo Elements/Direct Drafting then transfers the part to the ownership of the active part and deletes the original.

With Copy

To copy a part to the active part:

1. Press **PARTS 1**.
2. Pick **Copy** in GATHER PRT.
3. Identify the part to be gathered or enter its name.
4. Indicate a reference point for the copy operation.
5. Indicate the location for the reference point.

Creo Elements/Direct Drafting copies the part such that the new part is owned by the active part.

Example

Refer to [Figure 216. Gathering a Part](#) on page 394. You have incorrectly created the part RETAINING CLIP # 1 as a subpart of PISTON ASSEMBLY. Pick GATHER PRT to transfer RETAINING CLIP # 1 to its correct position as a subpart of WRIST ASSEMBLY.

Figure 216. Gathering a Part

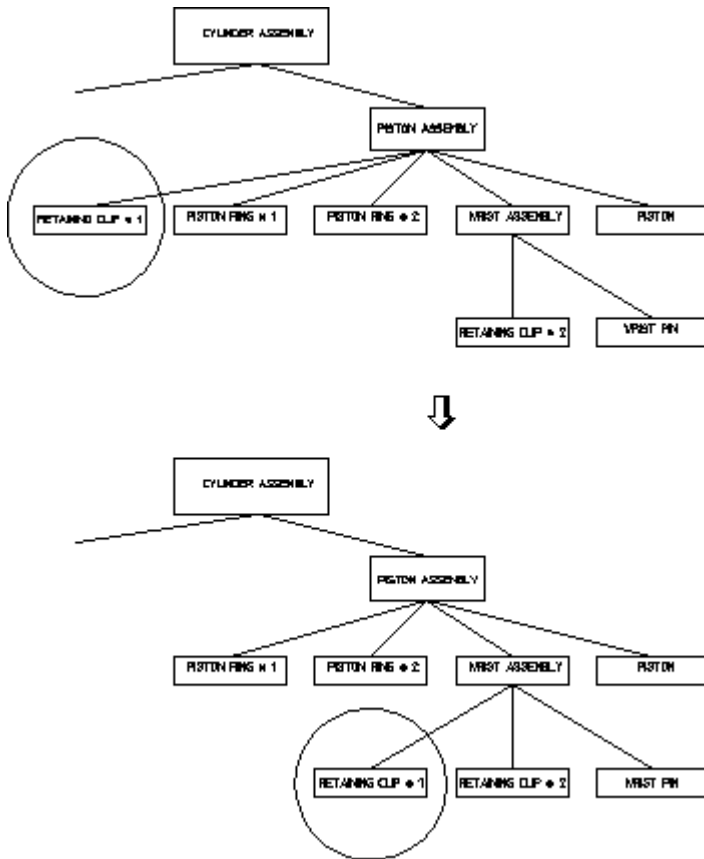

To transfer RETAINING CLIP # 1 to its correct position as a subpart of WRIST ASSEMBLY:

1. Press **PARTS 1**.
2. Pick Part in EDIT.
3. Identify WRIST ASSEMBLY.

Creo Elements/Direct Drafting makes WRIST ASSEMBLY the active part.

4. Pick Delete Old in GATHER PRT.
5. Identify RETAINING CLIP # 1.

Creo Elements/Direct Drafting transfers the part so that it becomes a subpart of WRIST ASSEMBLY.

Showing Parts

This section shows how to examine a selected groups of parts. Those you do not want to see are replaced by representative boxes. This can be useful where parts overlap.

The three SHOW options are:

- Part
- All
- Part Boxed

With Part

This is the default option. You can either restore a part presently represented by a box, or look at certain levels in the parts structure.

If you want to restore a boxed part:

1. Press **PARTS 1**.
2. Pick **Part** in **SHOW**.
3. Identify the part.

Creo Elements/Direct Drafting will redraw it normally.

However, if you wish to look down to a certain parts level and no further:

1. Enter the level number.
2. Press [Enter].

Creo Elements/Direct Drafting redraws the chosen viewport with all parts in the entered level and below shown as boxes.

For example, if you enter 3, the chosen viewport will be redrawn to show all parts in levels 1 and 2 with those in lower levels indicated by boxes. If a boxed part belongs directly to the active part, this is indicated by a yellow box.

With All

You can restore all parts in the chosen viewport to their normal appearance:

1. Press **PARTS 1**.
2. Pick **All** in **SHOW**.

Creo Elements/Direct Drafting immediately redraws the chosen viewport with all parts fully visible.

With Part Boxed

You can change a part and all its subparts to a box representation in the chosen viewport. The box will enclose all elements of the part.

1. Press **PARTS 1**.
2. Pick **Part Boxed** in **SHOW**.
3. Identify the part to be boxed or enter its name.

Creo Elements/Direct Drafting will redraw the chosen viewport with the desired part shown as a box.

Smashing Subparts

When you smash a subpart, the elements that comprise the identified part will be merged into the active part and the subpart will no longer exist.

To merge a subpart into the active part:

1. Press **PARTS 1**.
2. Ensure you have the correct part active.
3. Pick **SMASH SUBP**.
4. Identify the part to be smashed or enter the part name. The part to be smashed must belong to the active part.

Creo Elements/Direct Drafting will now transfer the elements of the identified part to the active part and delete the subpart.

Example

Refer to [Figure 217. Smashing Parts on page 397](#). You want to make a single part drawing (WRIST UNIT) from the assembly drawing WRIST ASSEMBLY.

Figure 217. Smashing Parts

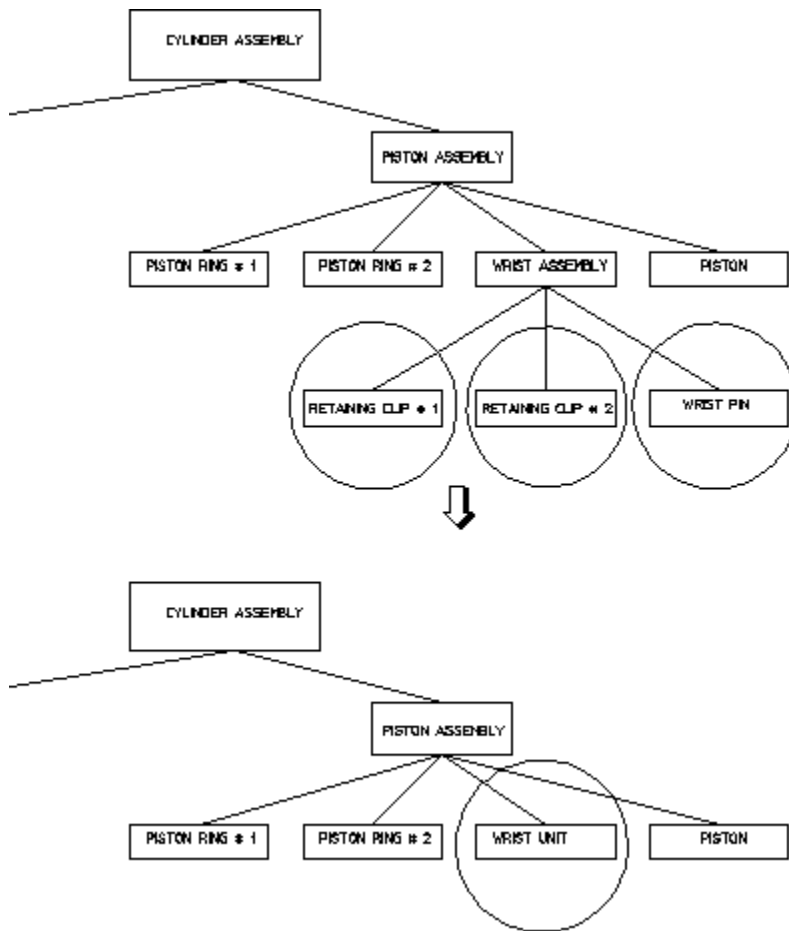

To create WRIST UNIT from WRIST ASSEMBLY:

1. Press **PARTS 1**.
2. Pick **Part** in **EDIT**.
3. Identify WRIST ASSEMBLY.
Creo Elements/Direct Drafting makes WRIST ASSEMBLY the active part.
4. Pick **SMASH SUBP**.
5. Identify RETAINING CLIP # 1, RETAINING CLIP # 2 and WRIST PIN.
Creo Elements/Direct Drafting transfers all drawing elements to the active part and then deletes the subparts.
6. Pick **RENAME** in **PARTS 2**.
Creo Elements/Direct Drafting prompts you for a new name for the active part.
7. Enter 'WRIST UNIT'

The SMASH SUBP command includes the options:

KeepData	When the subpart is smashed, it is drawn to the scale of the top part (scaling is maintained — drawing A).
KeepDisplay	When the subpart is smashed, it is brought into the top part as it is displayed on the screen (scaling is lost) – drawing B.

Figure 218. Effects of Smashing Scaled Parts

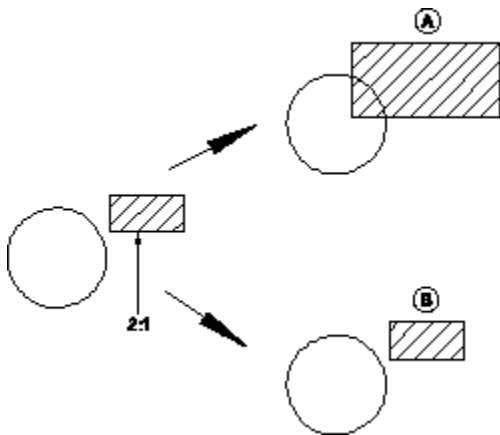

Note

- If the part to be selected is the master element of a group, the group is ungrouped before smashing
- If the part to be selected is a normal element of a group, the part is removed from the group before smashing.

Sharing Parts

This section shows how to make a shared part. Shared parts are useful if you require a particular part to appear several times in a drawing. See [Copying Shared Parts on page 399](#).

Examples of parts suitable for sharing are nuts, bolts, rivets, and other standard parts.

The geometry of a shared part always remains the same as the original part. However, the location of each shared part can be different and the overall size of each shared part can be altered by using the SCALE command.

You can also determine the plane in which the shared part lies by using the **ISOMETRIC** command from the **MODIFY** menu. If you place a shared part in a different plane, make it active and then turn on the **RULER / GRID**, so that they will also be displayed in the same plane.

The advantages of shared parts:

- Although you have several copies of the shared part displayed on your drawing, in memory you have only one. This saves you memory and allows you to carry out certain commands faster.
- If you change any geometry of a shared part, the changes will automatically appear in all other occurrences of that shared part in their respective planes. For example, if you add a horizontal line to a shared part, it will be displayed on the respective horizontal axis of each occurrence of that shared part.

To share a part:

1. Press **PARTS 1**.
2. Pick **SHARE**.
3. Identify the part to be shared.

The part must be non-active and may not be at a level above the active part or at the same level. Having indicated the part, it will become shared; its name will be followed by: **SHARED #1**, **SHARED #2** and so on (displayed in the parts listing only).

 **Note**

Any changes made to a shared part will automatically appear in all other occurrences of that shared part.

You cannot share a part above the active part or at the same level. Therefore you cannot share the Top Part.

All subparts of a shared part have their status set to shared.

When you rename a shared part, all occurrences of that shared part will be given the new name.

Copying Shared Parts

To create copies of a shared part:

1. Select the shared part you want to copy.
2. Press **MODIFY**.
3. Pick **Keep** in **MODIFY**.

4. Pick Multiple in MOVE to copy the part to the desired locations.

The following naming conventions apply to copies of shared parts:

- When you copy a shared part as described above, note that each copy will reflect the name of the original shared part. Each of these copies automatically receives a unique identifier. For example, when you copy a shared part named `rim3`, its copies will also be named `rim3`; however, each of these copies will have its own unique identifier. (`~2`, `~3`, etc).

The following example shows the parts structure of an assembly containing a shared part named `RIM` and a copy of this shared part.

```
[*] WHEEL ASSEMBLY [~1] [1:1]
    RIM [~2] [shared #1] [1:1]
    RIM [~3] [shared #1] [1:1]
```

- When you copy a shared part which owns another shared part (i.e. a shared subpart of a shared part), the copies of these shared subparts retain the same common name and identifier. However, each of the "owning" shared parts has its own unique identifier.

The following example shows the parts structure of an assembly containing a shared part named `RIM` which in turn owns a shared part named `LINER`.

```
[*] WHEEL ASSEMBLY [~1] [1:1]
RIM [~2] [shared #1] [1:1]
LINER [~3] [shared in shared #2] [1:1]
```

When you copy the `RIM`, the resulting parts structure will look like this:

```
[*] WHEEL ASSEMBLY [~1] [1:1]
RIM [~2] [shared #1] [1:1]
LINER [~3] [shared in shared #2] [1:1]
RIM [~4] [shared #1] [1:1]
LINER [~3] [shared in shared #2] [1:1]
```

Refer to [Unique Partnames on page 411](#) for further information.

Unsharing Parts

This section shows how to change a shared part back into a normal part.

This can be useful if you want to alter one occurrence of your shared part in isolation, as otherwise all occurrences will be altered simultaneously.

Note

You cannot unshare a part above the active part or at the same level.

To unshare a part:

1. Press **PARTS 1**.
2. Pick **UNSHARE**.
3. Identify the part to be unshared. The active status does not affect the command except that the part you wish to unshare cannot be active.

Creo Elements/Direct Drafting alters the parts structure so that the identified part is a normal part positioned alongside the shared parts and with the same parent. All other occurrences of the shared part stay shared.

Working with the Parts Editor

To display the PART STRUCTURE EDITOR window, pick PRT EDITOR in the PARTS 1 menu.

Figure 219. Parts Editor Menu

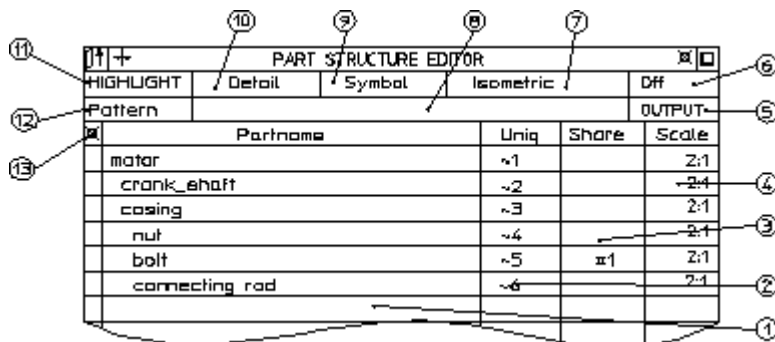

- 1 Partname of part
- 2 Unique partname of part
- 3 Whether part is a shared part
- 4 Drawing scale of part
- 5 Type of output required-printer or file
- 6 Show highlighting off
- 7 Highlight isometric parts
- 8 Field for pattern mask ('c*')
- 9 Highlight symbol parts
- 10 Highlight detail parts
- 11 Highlight button
- 12 Pattern for searching parts tree
- 13 Iconify/deiconify button (expands and collapses tree)

The parts editor does the following:

- You can scroll through the editor using the scrollbar.
- The page containing the current part is shown after the editor pops up. This is particularly useful when a drawing contains hundreds of parts.
- You can execute the commands **EDIT PART**, **GATHER PART**, and **SHARE**, and then pick a part from the parts editor (either from the **Partname** column or the **Uniq** column).

- The current part is highlighted (dark brown).
- If the parts editor is active, it is automatically updated.

Commands in the parts editor include:

HIGHLIGHT	Use this command with the options: <ul style="list-style-type: none"> • Detail — highlights detail parts only • Symbol — highlights symbol parts only • Isometric — highlights isometric parts only • Off — switches off highlighting
Pattern	Enter a pattern and all matching parts are highlighted.
OUTPUT	Prints parts tree information to a file or to a printer.

Shared parts within shared parts are shown as ##1.

Example: Highlighting Parts

To highlight a pattern:

1. Pick **HIGHLIGHT**
2. Pick **Pattern**
3. Enter 'c*'

The highlighted rows are:

```
crank_shaft      ~2      2:1
casing           ~3      2:1
connecting_rod   ~6      2:1
```

4. Enter '#1'

The highlighted rows are:

```
bolt             ~5  #1  2:1
```

5. Enter '~2'

The highlighted rows are:

```
crank_shaft      ~2      2:1
```

The parts tree that is displayed can be collapsed and expanded by picking the iconify/deiconify column. This is useful if you have a large assembly and do not want display nested parts.

To collapse the parts tree in the previous figure, pick the iconify/deiconify field as shown in figure [Figure 220. Using the Iconify/Deiconify Button on page 403](#). The parts tree collapses and an icon appears in the field to indicate a collapsed tree.

Figure 220. Using the Iconify/Deiconify Button

PART STRUCTURE EDITOR				
HIGHLIGHT	Detail	Symbol	Isometric	Off
Pattern				OUTPUT
<input checked="" type="checkbox"/>	Partname	Uniq	Share	Scale
	mator	~1		2:1
	crank_shaft	~2		2:1
<input checked="" type="checkbox"/>	casing	~3		2:1

Pick the icon again to expand the tree.

Producing a Parts List

This section shows how to produce a list of the parts in your drawing. The list produced can be displayed on the screen, printed, or written to a file by using the relevant function from OPTIONS (refer to the next section, [Parts List Options on page 405](#)).

To write the parts list to a file without an overwrite or append, just select the required PARTS LIST option and enter the filename.

The two PARTS LIST options are:

- Count
- Tree

Counting Parts

This is the default option. You can obtain a parts list of all parts owned by the current part and one level below that.

Part names beginning with a dot will not be listed, for example any detail part .1 [shared #1] [detail].

[Figure 221. Active Part and Part Count on page 404](#) shows the active part (arrowed) and the part count produced from this structure.

Figure 221. Active Part and Part Count

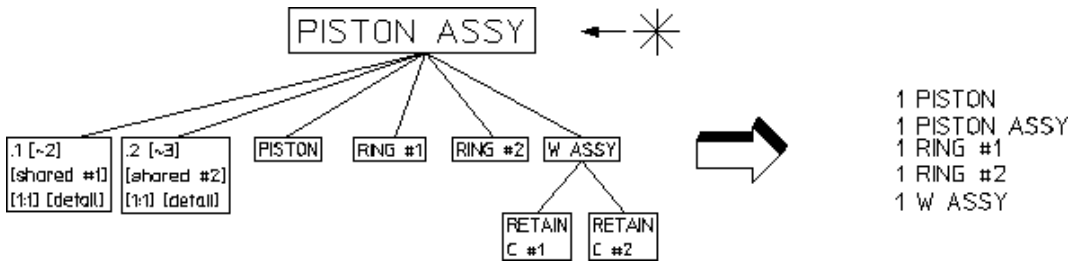

To produce a part count:

1. Press **PARTS 2**.
2. Check you have the correct part active.
3. Pick Count in PART LIST.
4. Pick the destination for the parts list in OPTIONS.

Creo Elements/Direct Drafting now produces the parts list and either writes it to a file, prints it, or displays it on the screen.

Producing a Parts Tree

You can produce a full parts list which shows all levels of your drawing.

The active part has an asterisk (*) in front of it and the hierarchy is shown by indentation.

Figure 222. Part Structure and Parts Tree Produced on page 404 shows the part structure and the parts tree produced from this structure:

Figure 222. Part Structure and Parts Tree Produced

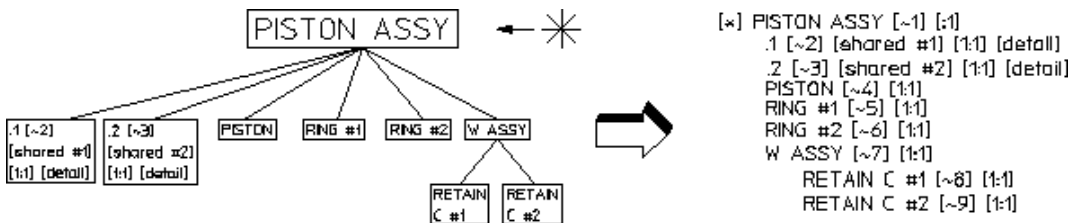

To produce a parts tree:

1. Press **PARTS 2**.
2. Pick Tree in PARTS LIST.
3. Pick the destination for the parts list in OPTIONS.

Part names beginning with a dot are listed as it is possible that they have subparts.

Parts List Options

This section shows how to direct your parts list to the correct device.

The four OPTIONS are:

- Screen
- Printer
- Delete Old
- Append

Screen

To send the parts list to the screen:

1. Press **PARTS 2**.
2. Pick the required PARTS LIST command.
3. Pick Screen.

Creo Elements/Direct Drafting clears the screen and displays the parts list.

Printer

To send the parts list to a locally connected printer:

1. Press **PARTS 2**.
2. Pick the required PARTS LIST command.
3. Pick Printer.

Creo Elements/Direct Drafting prints the parts list.

Delete Old

To send the parts list to an existing file and overwrite the old contents of the file:

1. Press **PARTS 2**.
2. Pick the required PARTS LIST command from the screen menu.
3. Pick Delete Old.
4. Enter the name of the file to be overwritten.

Append

To add the parts list to an existing file:

1. Press **PARTS 2**.
2. Pick the required PARTS LIST command from the screen menu.

-
3. Pick Append.
 4. Enter the name of the file to which the parts list should be appended.

Viewing Parts

This section shows how to view individual parts of your drawing.

You can only view drawings in the current viewport.

Use viewing in the following cases:

- During the design stage if parts overlap one another in a confusing way.
- To quickly inspect a finished part and check that it is complete.
- To reduce redraw time by viewing only the part(s) you are currently working on.

The three VIEW options are:

- Part
- Top
- Parent

With Part

This is the default option.

To look at an individual part:

1. Press **PARTS 2**.
2. Pick Part in VIEW.
3. Enter the name of the part to be viewed, or identify an element of the part in any viewport.

Creo Elements/Direct Drafting then redraws the chosen viewport containing only the desired part and any subparts belonging to it. The name of the part being viewed will be displayed in the top left corner of the viewport.

With Top

You can view your complete drawing in the current viewport.

This is useful if you have been viewing a lower level and want to quickly restore the complete drawing to the viewport:

1. Press **PARTS 2**.
2. Pick Top in VIEW.

The chosen viewport will be redrawn to show all the parts of your drawing. The name of the top part will be displayed in the top left corner of the viewport.

With Parent

You can view the parent of the presently viewed part. Parent allows you to view the next level up in the parts hierarchy:

1. Press **PARTS 2**.
2. Pick Parent in VIEW.

The current viewport will be redrawn displaying the parent of the active part and all parts belonging to the active part.

Spotlighting Parts

Spotlighting allows you to distinguish between the active part and all other parts. The function works as an on/off switch. We recommend you pick On in SPOTLIGHT when you are creating and modifying parts.

1. Press **PARTS 2**.
2. Pick Off in SPOTLIGHT.

All parts appear in their normal linetype and color, this makes it difficult to distinguish between the active part and all other parts.

3. Alternatively, pick On in SPOTLIGHT.

Only the active part has its normal appearance. All non-active parts are shown in magenta dotted lines.

Changing Parts into Symbols

This section shows how to change existing parts into symbols.

The only difference between a symbol and a normal part is that a symbol's size relative to the plotter paper does not change if you alter the DRAW SCALE (refer to [Preparing the Drawing Environment on page 28](#)).

An example of a symbol part could be a border to fit a particular paper size or any standard symbol. Once you've made a symbol part, it is best to store it so that it is ready to be loaded whenever you require it.

To make a symbol part:

1. Press **PARTS 2**.

-
2. Create the required shape as a part. This is best done with the DRAW SCALE set to 1.
 3. When the part is finished, pick SYMBOL On in **PARTS 2**.
 4. Identify the part or enter its name.

Creo Elements/Direct Drafting now defines the part as a symbol part. Check this by picking PARTS LIST and then Screen. You will see the part's name is followed by [symbol].

You can also change a symbol part back into a normal part:

1. Press **PARTS 2**.
2. Pick SYMBOL Off.
3. Identify the symbol part or enter its name.

Creo Elements/Direct Drafting will now change the symbol part back into a normal part.

Setting the Part Reference Point

This section shows how to set a reference point in the active part.

The reference point is used:

- To locate other parts when loading from files.
- For symbols.
- For some GATHER commands.

The Creo Elements/Direct Drafting default reference point is the lower left corner of an imaginary box placed around the elements of the part.

To set a reference point:

1. Press **PARTS 2**.
2. Pick SET REF PT in **PARTS 2**.

The present reference point for the active part will be shown by a line joined to the cursor.

3. Indicate the new reference point.

Renaming Parts

This section shows how to change the name of the active part. To rename the active part:

1. Press **PARTS 2**.

2. Pick **RENAME** in **PARTS 2**.

Creo Elements/Direct Drafting displays the name of the active part and prompts you for a new name.

3. Enter the new name enclosed by quotes (' ' or " ").

Creo Elements/Direct Drafting now changes the part name to the new name.

You can check the new name by looking at the active name displayed in the System Status Line.

Multiple Drawing Scales

Creo Elements/Direct Drafting supports multiple drawing scales on one drawing. This lets you place small and large parts on the same drawing for manufacturing and documentation purposes.

The scale associated with a part can be seen in the parts tree. To change the drawing scale:

1. Create a top part and a subpart.

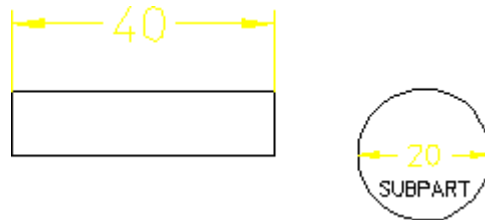

2. Look at the parts tree (Tree in PART LIST).

It should look similar to the following:

```
[*] Top [~1] [1:1]
    SUBPART [~2] [1:1]
```

3. Pick **Prt+Subprt** in **PART SCALE (PARTS menu)**.
4. Identify the top part (both parts are highlighted).
5. Enter 2.

Creo Elements/Direct Drafting scales both the top part and subpart by the scaling factor 2.

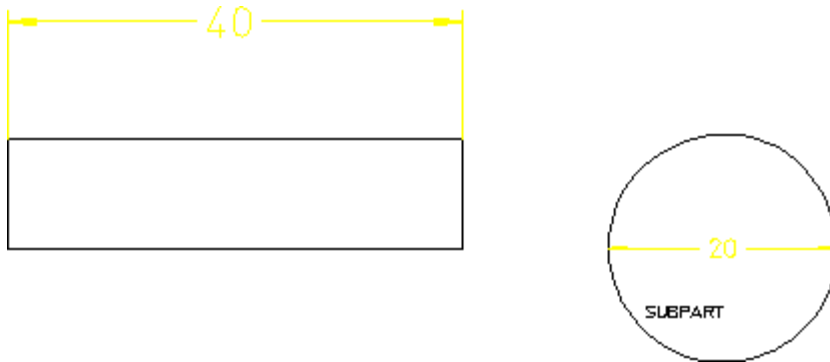

Now look at the parts tree again to see how the scaling factors change:

```
[*] Top [~1] [2:1]
SUBPART [~2] [2:1]
```

1. Pick **Prt Only** in PART SCALE.
2. Identify the subpart (it does not need to be active).
3. Enter 3.

Creo Elements/Direct Drafting scales the subpart only.

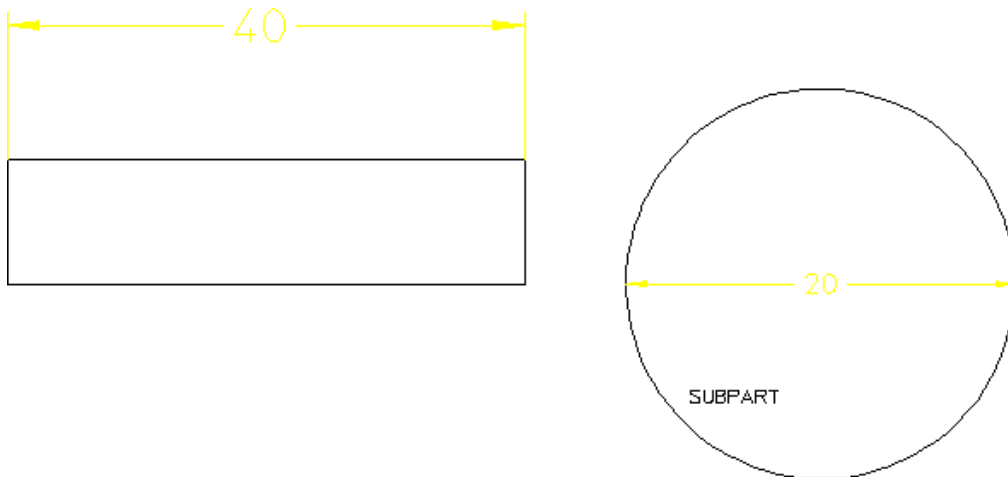

Now look at the parts tree again to see how the scaling factors change:

```
[*] Top [~1] [2:1]
SUBPART [~2] [3:1]
```

Notice that the subpart is scaled according to its original value. In other words, it is scaled by a factor 3 — not 2 and then 3.

Text, dimensioning text, and symbols are not changed.

Scaling Parts about a Reference Point

The command SCALE REF scales parts and subparts about the center or about the reference point (as set by SET REF PT command).

Unique Partnames

Creo Elements/Direct Drafting automatically generates names for parts when you create them. These names are shown in the parts tree and are represented by numbers: [~1], [~2], This feature is useful when handling parts by macros. For example, a typical parts tree may look:

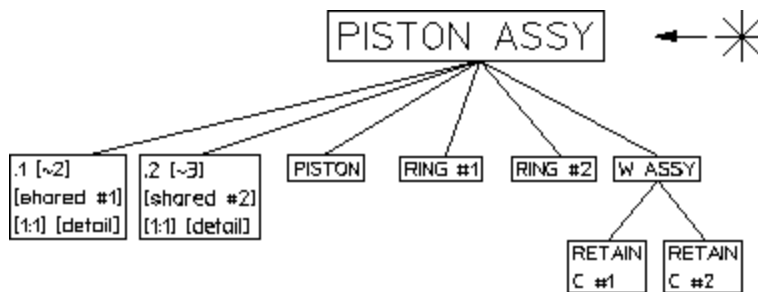

```

[*] PISTON ASSY [~1] [1:1]
    .1 [~2] [shared #1] [1:1] [detail]
    .2 [~3] [shared #2] [1:1] [detail]
    PISTON [~4] [1:1]
    RING #1 [~5] [1:1]
    RING #2 [~6] [1:1]
    W ASSY [~7] [1:1]
        RETAIN C #1 [~8] [1:1]
        RETAIN C #2 [~9] [1:1]
  
```

The symbols and characters have the following meaning:

[*]	Current part (shown here as top part)
[~1]	Unique partname of part—automatically generated (from 1 to n)
[1:1]	Draw scale factor of the part (top or parts).
.1	Partname of detail part—automatically generated (from .1 to n)
[shared #1]	Shared part
[detail]	Detailed part.

Unique-parts naming has the following functionality:

- Each part is specified by a number.
- Shared parts within shared parts are identified with the same unique partname because they exist once only in the data structure.

Shared parts within shared parts are marked with [shared in shared #n]

- Parts can be made active by entering one of the following commands:

```
EDIT_PART 'bracket'  
EDIT_PART '~2'
```

If you enter `EDIT_PART` and the parts structure has more than one part with the same partname, Creo Elements/Direct Drafting prompts you to specify the part number.

With `INQ 900` and `INQ 901`, you get a string list of unique partnames (~2, ~3).

- `INQ_ENV 8 INQ 5` for inquiry of the offset. For loading several drawings, the maximum used unique partname can be inquired (useful when running macros).
- `DELETE ALL CONFIRM` resets the parts numbering.
- Refreshing partnames can be done by entering the command:
`RESET_PART_NUMBER`

Further Information

For further technical information about parts, the parts structure and so on, refer to the Creo Elements/Direct Drafting help system:

Enter `help parts` at the Creo Elements/Direct Drafting command line.

The screen will clear and Creo Elements/Direct Drafting will display further information about parts.

13

Generating Hidden Lines

Introduction to Hidden Lines	414
Hidden Line — Tutorial Example 1	419
Setting the Current Offset.....	424
Setting Z-Values	424
Generating Faces and Setting Z-Values in a Complete Part	427
Checking Z-Values	428
Generating Faces.....	433
Deleting Covering Faces.....	435
Redrawing in Hidden or Normal Mode.....	436
Coloring Faces.....	437
Viewing a Range of Z-Values.....	438
Generating Hidden Lines	440
Loading the Backup Drawing.....	441
Setting How Hidden Lines are Displayed	441
Plotting Hidden Lines.....	443
Dumping Hidden Lines.....	443
Hidden Line – Tutorial Example 2	443
Creating the Crank Assembly	443

Introduction to Hidden Lines

The 2D hidden line module is used during the creation of an assembly drawing to automatically generate lines that indicate hidden drawing features. In an assembly drawing, these lines are normally shown dashed.

To create an assembly drawing that includes hidden lines, you must:

- Load parts.
- Generate faces (without faces you cannot generate hidden lines).
- Assign each face a logical level in the z direction (a z-value).
- Use the z-value information to generate the appropriate hidden lines.

During the drawing process you can selectively view faces for clarity (ensure that each face is correctly positioned in relation to the others).

Use one of the following methods to redraw your assembly drawing you have generated hidden lines:

- Pick **HIDD DRAW** – this mode effectively redraws your assembly drawing, removing those lines that will later be generated as hidden. You must first have generated faces.
- Pick **NORM DRAW** – this is the normal Creo Elements/Direct Drafting redraw mode.

On completion of your assembly drawing you can generate hidden lines in the dashed linetype (default).

Note

Pick **With Backup** in **GEN HIDDEN** to store your assembly drawing (in `workfile.hid`) before generating hidden lines. The **GEN HIDDEN** command smashes the parts structure and creates the hidden line geometry.

Two tutorial examples have been included:

- A simple example using a Frame Assembly will clarify the general procedure.
- A realistic example creates a component assembly drawing (`CRANK_ASSEMBLY`).

Press **2D HIDDEN LINE** to access the hidden line menus.

What are Faces?

Faces can be thought of as freely definable, infinitely thin, shaped areas that form part of an assembly. Faces can partially obscure or completely cover other faces (depending upon their z-values). You can delete any covering face by picking DEL FACE in MENU2 and identifying the face. Note that the face to be deleted must be in the active part.

In simple terms, you could imagine faces as pieces of paper, laid one on top of another, thus obscuring elements with a lower z-value.

Figure 227. Faces — With Z-Values 0 and 1 on page 415 shows the faces of two components (one with z-value 0 and the other with z-value 1).

Figure 227. Faces — With Z-Values 0 and 1

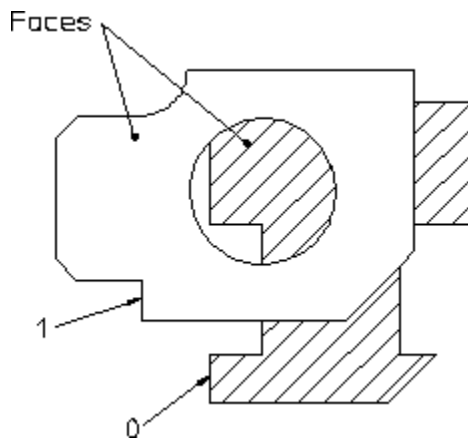

Note

A face does not necessarily need to have the same z-value as its boundary lines. In this case the boundary lines of the face may be partially covered by the face itself (solid lines may appear dashed in some cases). Note, the linetype of the boundary lines is not changed.

Faces are defined in one of the following ways:

- Automatic face search for an entire part (Creo Elements/Direct Drafting tries to find a maximum number of faces contained within a part. All faces are assigned the same z-value).
- Automatic face search for an entire part (with hole recognition).
- Automatic face search by picking (similar to automatic hatching).
- Manual face specification (similar to manual hatching).

What are Z-Values?

A z-value is the numerical value assigned to an element to position it in the drawing at the appropriate logical level in the z-direction.

Newly created elements are assigned the current z-value. The current z-value is always displayed in the System Status Line.

See [Figure 228. Visualizing Z-Values](#) on page 416.

Figure 228. Visualizing Z-Values

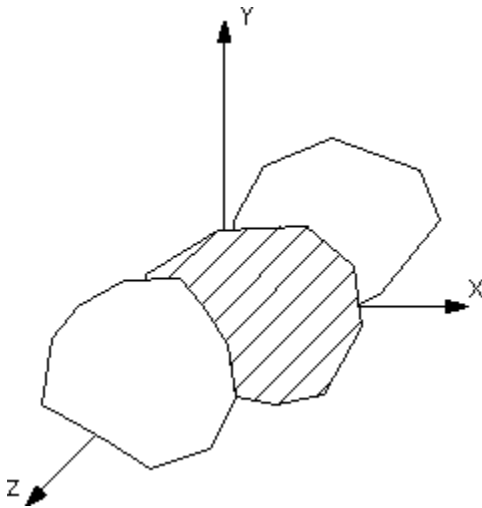

For example, three faces could be given the z-values 0, 1, 2. The face with z-value 1 would be positioned above that with z-value 0. The face with z-value 2 would be positioned above those with z-values 1 and 0. Depending on where these faces were positioned with respect to each other, certain areas would be obscured.

[Figure 229. Z-Values 0, 1 and 2](#) on page 417 shows 3 faces assigned the z-values 0, 1 and 2.

Figure 229. Z-Values 0, 1 and 2

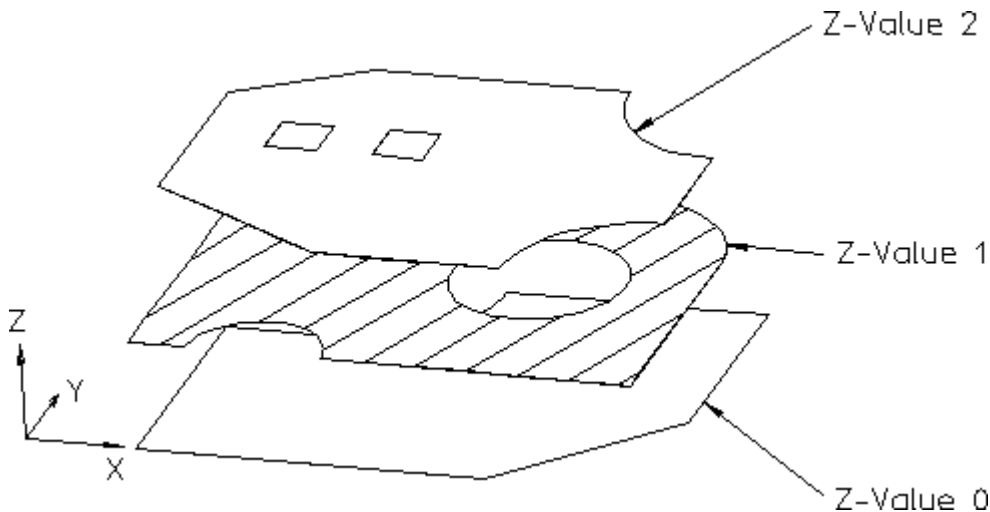

Hatches are treated as faces. This means hatched areas can cover geometry and faces. Hatches that are partially covered are displayed partially obscured.

Construction geometry, texts, leader lines and dimensions are always visible.

Parts cannot be given a z-value, with the exception of shared parts (see [Assigning a Z-Value on page 426](#)).

You can specify z-values in three ways:

- Automatically — if you have pressed **2D HIDDEN LINE** and thus loaded the hidden line module. Future elements you create are assigned the current z-value.
- By defining "element-to-element" relations (Above, Same, Below, Between).
- By entering a z-value (real number) for the specified elements.

Elements and geometry without a z-value are automatically positioned below the element(s) with the lowest z-value. Construction geometry, text, dimensions and leader lines are always at the top.

[Figure 230. Z-Value Structure within a Drawing on page 418](#) shows how the z-value structure relates to your drawing:

Figure 230. Z-Value Structure within a Drawing

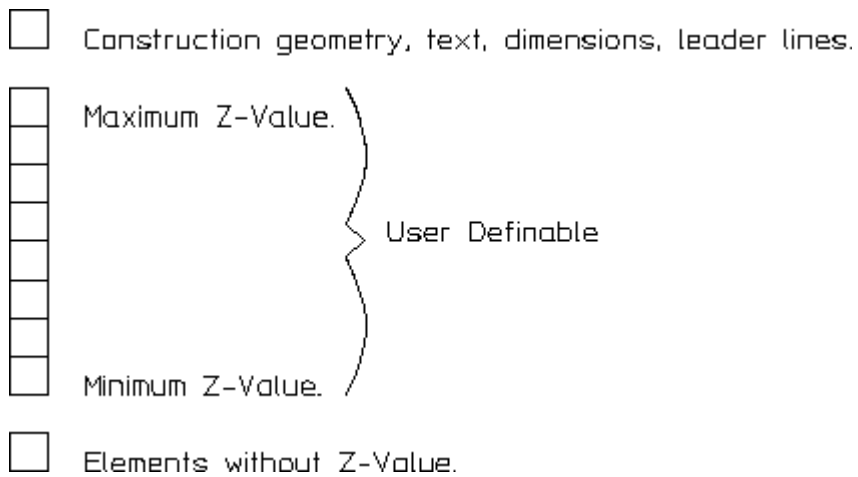

Z-Values and Shared Parts

You can assign z-values to shared parts to enable them to be placed on different logical levels.

The z-values of elements within a shared part are calculated as the sum of their own z-value and the z-values of all their shared parent parts.

Hidden Line Modes

The two hidden line modes are:

- View Mode – produces a hidden line display, does not compute hidden lines, does not change geometry.
- Hidden Line Generation Mode – used to finish the assembly drawing before plotting, changes geometry.

View Mode

This mode produces a hidden line display of the assembly on the screen without computing the hidden lines. It does not change the geometry or the parts structure. Therefore you can assign z-values to elements during construction. Changes in z-value are possible at any time and are displayed immediately.

Generation Mode

Hidden Line Generation Mode is used to finish an assembly drawing before plotting.

In contrast to the view mode, geometry is modified:

-
- Elements are split.
 - Shared parts will be unshared.
 - The parts structure is completely smashed.

The hidden lines can be switched on and off by picking Show On or Show Off in HIDD LINES.

Hidden Line and Viewing a Drawing with Dynamic

You cannot use display lists (Displ List On in WINDOW) together with hidden line redraw mode (HIDD DRAW in 2D HIDDEN LINE) in the same viewport.

Hidden Line — Tutorial Example 1

This tutorial shows how to make a simple assembly drawing (Frame_Assy) and use it to create:

- An assembly view with the hidden lines to be generated as yet invisible (View Mode).
- An assembly view showing dashed hidden lines (Generation Mode).

Creating Frame Assembly

First make the assembly drawing Frame Assembly by creating two parts, Frame 1 and Frame 2.

Initial Steps

1. Press **DELETE ALL CONFIRM** to clear the screen.
2. Press **PARTS 2**.
3. Pick RENAME in **PARTS 2** to rename the top part.
4. Enter "Frame Assembly"

Drawing Frame 1

1. Pick MENU 1 in PARTS 2.
2. Pick Part in INITIATE.
3. Enter "Frame 1"
4. Press **2D HIDDEN LINE**.
5. Pick CURR Z-VAL.
6. Enter 1

7. Press **CREATE**.
8. Pick Rectangle in LINE.
9. Draw two rectangles as shown in [Figure 231. Frame 1 on page 420](#).

Figure 231. Frame 1

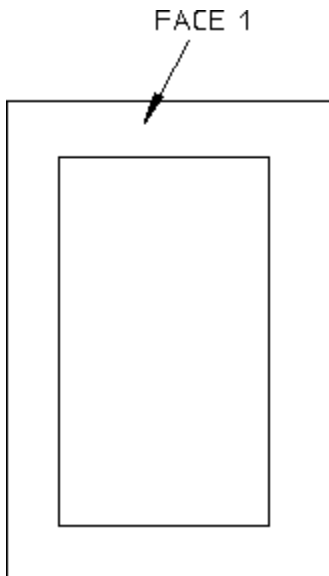

Generating Face 1

1. Press **2D HIDDEN LINE**.
2. Pick Singl Auto in GEN FACE.
3. Identify Face 1 (see [Figure 231. Frame 1 on page 420](#)).
Creo Elements/Direct Drafting creates Face 1.
4. Press **END**.

Drawing Frame 2

1. Pick MENU 1 in PARTS 2.
2. Pick Part in INITIATE.
3. Enter "Frame 2"
4. Press **2D HIDDEN LINE**.
Creo Elements/Direct Drafting displays the current z-value on the status line.
5. Pick CURR Z-VAL.
6. Enter 2
7. Press **CREATE**.

-
- Pick Rectangle in LINE.
 - Draw two more rectangles as shown in [Figure 232. Frame 1 and Frame 2 on page 421](#).

Figure 232. Frame 1 and Frame 2

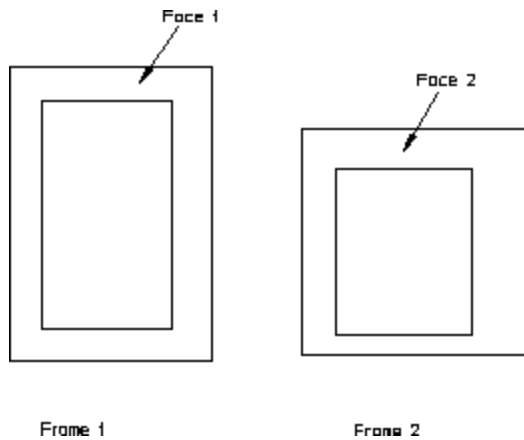

Generating Face 2

- Press **2D HIDDEN LINE**.
- Pick Singl Auto in GEN FACE.
- Identify Face 2.
- Press **END**.

Position Frame 2 Above Frame 1

- Press **MODIFY**.
- Pick No Keep in **MODIFY**.
- Identify Frame 2 by enclosing it in a box.
- Pick 2 Pts in MOVE.
- Identify a reference point for the move.
- Reposition Frame 2 above Frame 1 as shown in [Figure 233. Frame 2 Above Frame 1 on page 422](#).

Figure 233. Frame 2 Above Frame 1

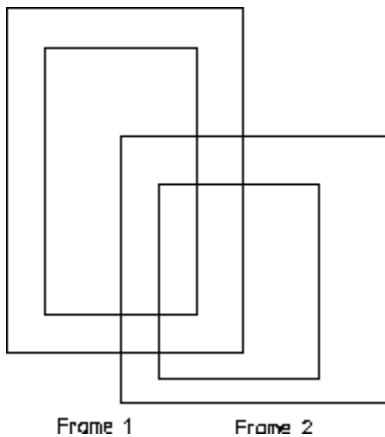

Assembly — Hidden Lines Invisible

You can display your assembly drawing so that the lines that will be generated as hidden are removed. This is useful as a check to see exactly which lines in your assembly will be generated as hidden lines.

1. Press **2D HIDDEN LINE**.
2. Pick **HIDD DRAW**.
3. Identify the current viewport.

To confirm hidden mode, Creo Elements/Direct Drafting displays -H- in the top left hand corner of the viewport (after the part name of the viewport top part).

Creo Elements/Direct Drafting redraws the assembly with the lines that will be generated as hidden invisible, see [Figure 234. Assembly View with Hidden Lines Invisible on page 422](#).

Figure 234. Assembly View with Hidden Lines Invisible

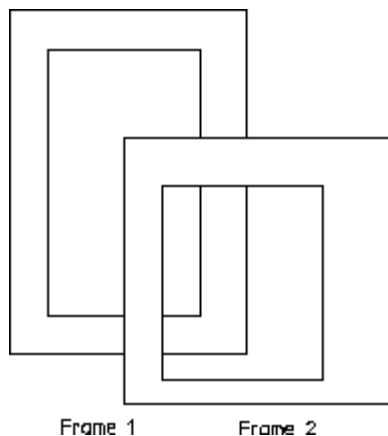

Assembly — Hidden Lines Shown Dashed

At this point you will generate the actual hidden lines.

Caution

Pick With Bckup in GEN HIDDEN to store your assembly drawing (in `workfile.hid`) before generating hidden lines. The GEN HIDDEN command smashes the parts structure and creates the hidden line geometry.

1. Press **PARTS 1**
2. Pick EDIT Top.
3. Press **2D HIDDEN LINE**.
4. Pick MENU 2.
5. Pick With Bckup in GEN HIDDEN.
6. Press **CONFIRM**.

Creo Elements/Direct Drafting stores your original drawing in `workfile.hid` (in your current directory) and generates hidden lines in the version displayed on the screen.

Creo Elements/Direct Drafting redraws the assembly with the hidden lines shown dashed, see [Figure 235. Assembly with Hidden Lines Shown Dashed on page 423](#).

Figure 235. Assembly with Hidden Lines Shown Dashed

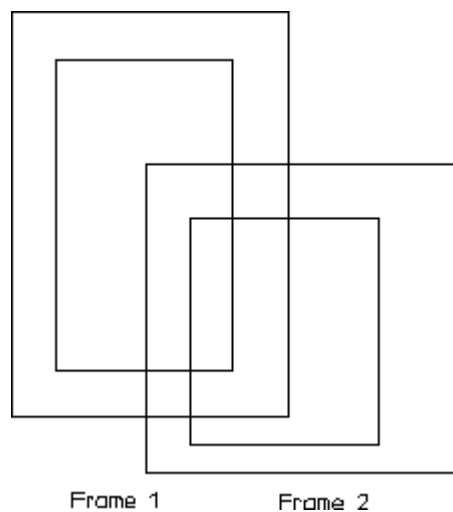

Setting the Current Offset

The current offset in the z-direction is used to calculate the z-value used in the above/below/between relationship with another element. The current offset z-value is added to/subtracted from the z-value of a reference element.

To set the current offset:

1. Press **2D HIDDEN LINE**.
2. Pick **CURR OFFST**.
3. Enter the current offset z-value.

Setting Z-Values

This section shows how to assign and change component z-values.

The SET Z-VAL options are:

- Elements
- Shared Prt

Use the normal Creo Elements/Direct Drafting selection techniques to select the elements to which you intend to assign z-values.

If you identify a part and you have selected the option Elements, all elements in that part are assigned the specified z-value. This works recursively down to all subparts.

Additional options for the above command are:

- Above
- Same
- Below
- None
- Between

You can set a z-value by picking Element in SET Z-VAL and entering a numerical value; this is assigned to each drawing element in your selection.

The Creo Elements/Direct Drafting default is that any existing z-values will be overwritten. If you don't want to overwrite z-values that have already been assigned:

1. Pick Element.
2. Indicate the elements to which you wish to assign z-values.
3. Enter **KEEP** via the keyboard.
4. Enter a numerical value.

You can also pick one of the options Above, Below, Same, or Between. This will result in a computed z-value.

 **Note**

These options only influence elements that already have a z-value assigned to them.

If you select a group of elements for a z-value change that have a range of z-values (lower limit – upper limit) already associated with them, the range relationship will be maintained.

To understand the effect of using the options Above, Below, Same, or Between, refer to the following four examples:

Example 1

Suppose you have a group of elements with computed z-values 1 to 9 and you then specify that they are placed at the same (pick Same) z-value as a reference element with a computed z-value of 20.

The result of this operation is that the z-values of all nine elements are computed and set in the range 20 to 28.

Example 2

Suppose you have a group of elements with computed z-values 1 to 9 and you then specify that they are placed above (pick Above, CURR OFFSET = 1) a reference element with a computed z-value of 20.

The result of this operation is that the z-values of all nine elements are computed and set in the range 21 to 29.

Example 3

Suppose you have a group of elements with computed z-values 1 to 9 and you then specify that they are placed below (pick Below, CURR OFFSET = 1) a reference element with a computed z-value of 20.

The result of this operation is that the z-values of all nine elements are computed and set in the range 11 to 19.

Example 4

Suppose you have a group of elements with computed z-values 1 to 9 and you then specify that they are placed between (pick Between, CURR OFFSET = 1) a reference element with a computed z-value of 20 and another reference element with a computed z-value of 40.

The result of this operation is that the z-values of all nine elements are computed and set in the range 21 to 29.

Assigning a Z-Value

To assign a z-value to an element:

1. Press **2D HIDDEN LINE**.
2. Pick Elements.
3. Identify the required elements.
4. Enter the z-value required.

Assigning a Z-Value to a Shared Part

To assign a z-value to a shared part:

1. Press **2D HIDDEN LINE**.
2. Pick Shared Prt.
3. Identify the shared part.
4. Enter the z-value.

Deleting a Z-Value

To delete a z-value of an element or a shared part:

1. Press **2D HIDDEN LINE**.
2. Pick Elements to delete a z-value belonging to an element or pick Shared Prt to delete a z-value belonging to a shared part.
3. Identify the element(s) or the shared part.
4. Pick None in OPTIONS.

Positioning an Element at a Z-Value Above Another Element

To position an element at a z-value above another element:

1. Press **2D HIDDEN LINE**.
2. Pick Elements.
3. Identify elements to be set above the reference element.
4. Pick Above in OPTIONS.
5. Identify the reference element.

Positioning an Element at a Z-Value Below Another Element

To position an element at a z-value below another element:

1. Press **2D HIDDEN LINE**.
2. Pick Elements.
3. Identify elements to be set below the reference element.
4. Pick Below in OPTIONS.
5. Identify the reference element.

Setting an Element's Z-Value the Same As Another

To set the same z-value:

1. Press **2D HIDDEN LINE**.
2. Pick Elements.
3. Identify elements to be set at the same z-value as a reference element.
4. Pick Same in OPTIONS.
5. Identify the reference element.

Positioning an Element at a Z-Value Between Two Other Elements

To insert an element at a z-value between two other elements:

1. Press **2D HIDDEN LINE**.
2. Pick Elements.
3. Identify elements to be set between the reference elements.
4. Pick Between in OPTIONS.
5. Identify the lower reference element.
6. Identify the upper reference element.

Generating Faces and Setting Z-Values in a Complete Part

This section shows you how to easily generate faces and set z-values in a complete part. Using the With Holes option, you can detect the presence of holes to prevent them being generated as faces.

The POS IN PRT options are:

-
- Elms&Faces
 - With Holes

Generating All Faces and Setting All Z-Values

To automatically generate all faces and set all z-values for all elements in a complete part:

1. Press **2D HIDDEN LINE**
2. Pick **Elms&Faces**.
3. Identify the part.
4. Enter the z-value or pick Above, Same, or Below.
5. Press **END**. Creo Elements/Direct Drafting generates all faces and assigns z-values to all elements in your part.

Generating All Faces - Ignoring Holes and Setting All Z-Values

To automatically generate all faces ignoring any holes and set all z-values for all elements in a complete part:

1. Press **2D HIDDEN LINE**
2. Pick With Holes.
3. Identify the part.
4. Enter the z-value or pick Above, Same, or Below.
5. Press **END**.

Creo Elements/Direct Drafting generates all faces ignoring any holes and assigns z-values to all elements.

Checking Z-Values

This section shows how to check z-values.

An Element's Z-Value

To check the z-value of an individual element:

1. Press **2D HIDDEN LINE**.
2. Pick Absolute in INQ Z-VAL.
3. Identify the element.

Creo Elements/Direct Drafting displays the element's z-value in the System Input Line (if the specified element has no assigned z-value, an error beep is given). The value is also written into the System Inquiry Array.

An Element Belonging to a Shared Part

If the element whose z-value you wish to know belongs to a shared part, the z-value is computed as the z-value of the element itself plus the z-values of all parent shared parts.

Example

Refer to [Figure 236. Z-Values for Shared Parts on page 429](#).

To check the computed z-value of an individual element with z-value 2 in Shared_part1:

1. Press **2D HIDDEN LINE**.
2. Pick Absolute in INQ Z-VAL.
3. Identify an element with z-value 2.

Creo Elements/Direct Drafting calculates the element's z-value as follows:

Element at z-value 2 + z-value of Shared_part1.

$$2 + -5 = -3.$$

Figure 236. Z-Values for Shared Parts

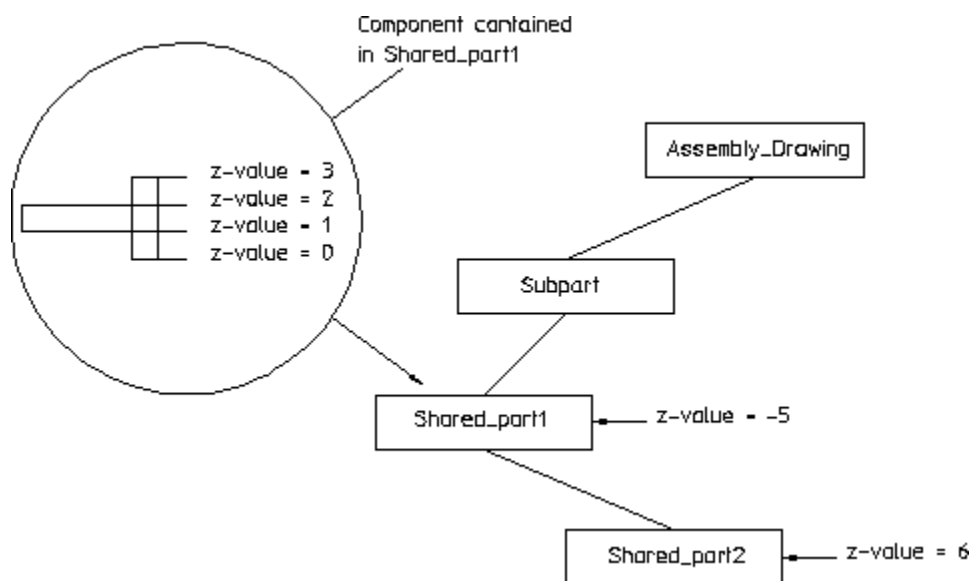

The Minimum Z-Value in an Assembly Drawing

To check the minimum z-value:

1. Press **2D HIDDEN LINE**.
2. Pick **Minimum** in **INQ Z-VAL**.

Creo Elements/Direct Drafting displays the minimum z-value in the assembly drawing on the System Input Line (if the drawing has no z-values assigned, an error beep is given). The value is also written into the System Inquiry Array.

The Maximum Z-Value in an Assembly Drawing

To find the maximum z-value:

1. Press **2D HIDDEN LINE**.
2. Pick **Maximum** in **INQ Z-VAL**.

Creo Elements/Direct Drafting displays the maximum z-value in the assembly drawing in the System Input Line (if the drawing has no z-values assigned, an error beep is given). The value is also written into the System Inquiry Array.

The Z-Value of a Shared Part

To find the computed z-value of a shared part:

1. Press **2D HIDDEN LINE**.
2. Pick **ShPrtOffset** in **INQ Z-VAL**.
3. Identify the shared part.

Creo Elements/Direct Drafting computes the z-value as the sum of the shared part's z-value and that of the shared parent part and displays it in the System Input Line. The value is also written into the System Inquiry Array.

Example

Refer to [Figure 236. Z-Values for Shared Parts on page 429](#).

To check the z-value of Shared_part2:

1. Press **2D HIDDEN LINE**.
2. Pick **ShPrtOffset** in **INQ Z-VAL**.
3. Identify Shared_part2.

Creo Elements/Direct Drafting calculates the shared part's z-value as follows:

Z-value of Shared_part2 + z_value of parent. In this case,

$$-5 + 6 = 1.$$

The Z-Value of an Element in a Shared Part

To find the z-value of an element in a shared part:

1. Press **2D HIDDEN LINE**.
2. Pick **ShPrt Elem** in **INQ Z-VAL**.
3. Identify the element in the shared part.

Creo Elements/Direct Drafting displays the element's z-value in the System Input Line. The value is also written into the System Inquiry Array.

The Current Z-Value

To check the default current z-value assigned to each newly created drawing element:

1. Press **2D HIDDEN LINE**.
2. Pick **Curr Z-Val** in **INQ Z-VAL**.

Creo Elements/Direct Drafting displays the current z-value in the System Input Line. If required, it can be used as input without retyping. The current z-value is also written into the System Inquiry Array.

The Load Value

To check the current load z-value:

1. Press **2D HIDDEN LINE**.
2. Pick **LOAD Z-VAL**.

Creo Elements/Direct Drafting displays the current load mode and load z-value on the System Input Line. If required, it can be used as input without retyping. Both these values are written into the System Inquiry Array.

Setting the Default Z-Value

This section shows how to define a specific z-value which is assigned to each newly created element (the default current z-value is 0). The default current z-value is displayed in the System Status Line and in the menu field immediately to the right of the **CURR VALUE** command.

To set a current z-value:

1. Press **2D HIDDEN LINE**.
2. Pick **CURR Z-VAL**.
3. Enter the new z-value or pick Above, Same, or Below.

Creo Elements/Direct Drafting assigns this value as the current z-value, assigned by default to each newly created element.

Setting the Load Value

This section shows how to define a loading offset in the z-direction for elements that are loaded in the future.

The default load z-value is NONE. If you load elements with the load z-value set to NONE, their z-value (if any) remains unchanged.

To set a load offset z-value:

1. Press **2D HIDDEN LINE**.
2. Pick **LOAD Z-VAL**.
3. Pick **Same** in **OPTIONS**.
4. Identify a reference element with a z-value of 2.
5. Enter the new load z-value or pick Above, Same, or Below.

Creo Elements/Direct Drafting assigns the required load z-value to any elements loaded in the future.

Example

To load drawing elements with a load z-value of 2:

1. Press **2D HIDDEN LINE**.
2. Pick **LOAD Z-VAL**.
3. Enter 2.
4. Press **FILE 1**.
5. Pick **LOAD**.
6. Enter the drawing name.

Creo Elements/Direct Drafting loads the drawing elements as shown in [Figure 237. Loading Drawing Elements with a Load Z-Value of \$\geq 2\$ on page 433](#).

Figure 237. Loading Drawing Elements with a Load Z-Value of ≥ 2

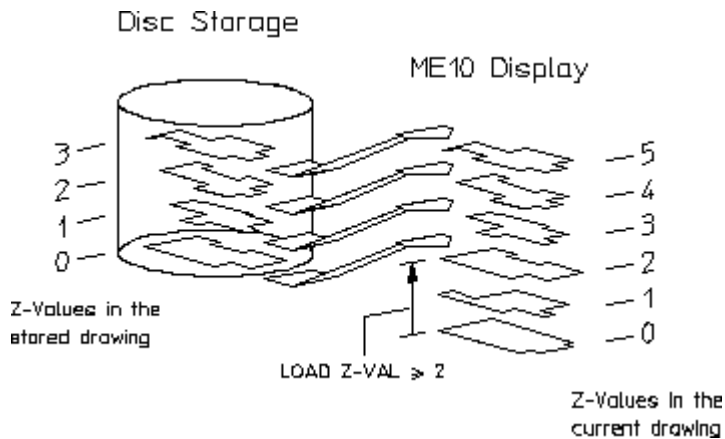

Generating Faces

This section shows how to specify covering faces. A covering face will effectively cover all geometry (or faces) with a lower z-value. Newly created faces are assigned the current z-value by default. The covering face will adopt the default face color (note that you can set a default color for faces).

The GEN FACE options are:

- All In Prt
- Singl Auto
- With Holes
- Singl Manl

Automatically

You can automatically generate faces if:

- All elements of the contour are in the active part.
- The contour has no gaps.
- Each vertex of the contour is a vertex of all elements there.

To automatically generate faces:

1. Press **2D HIDDEN LINE**.
2. Pick **Singl Auto** in **GEN FACE**.
3. Indicate a point inside the face.
4. Enter a z-value or pick Above, Same, or Below.

Creo Elements/Direct Drafting generates the face automatically and assigns the required z-value.

All Faces in a Part Excluding Holes

To automatically generate all faces in a part and exclude any holes:

1. Press **2D HIDDEN LINE**.
2. Pick **With Holes** in **GEN FACE**.
3. Enter a z-value or pick Above, Same, or Below.

Creo Elements/Direct Drafting generates the faces automatically and assigns the required z-values. Note that any holes that are present are excluded from face generation.

Manually

Note that in order to build up a contour with elements, a vertex of an element must be specified first. Thereafter, the elements which make up the contour can be selected by a simple pick.

Creo Elements/Direct Drafting will allow you to skip elements along a contour as long as not more than one element after any branch point is skipped. All elements must be in the active part.

To manually generate a face:

1. Press **2D HIDDEN LINE**.
2. Pick **Singl Manl** in **GEN FACE**.
3. First indicate points along the outer contour (the points selected do not have to lie on any geometric element).
4. Indicate points along the inner contour.
5. Press **END**.
6. Enter a z-value or pick Above, Same, or Below.

Automatically Generating All Faces in a Part

You can generate faces automatically in the active part. Creo Elements/Direct Drafting tries to find the maximum number of faces.

To automatically generate faces in the active part:

1. Press **2D HIDDEN LINE**.
2. Pick **All In Prt** in **GEN FACE**.
3. Enter a z-value or pick Above, Same, or Below.

Example

Refer to [Figure 238. Automatically Generating Faces In a Part](#) on page 435. In this example Creo Elements/Direct Drafting would generate the four faces shown.

Figure 238. Automatically Generating Faces In a Part

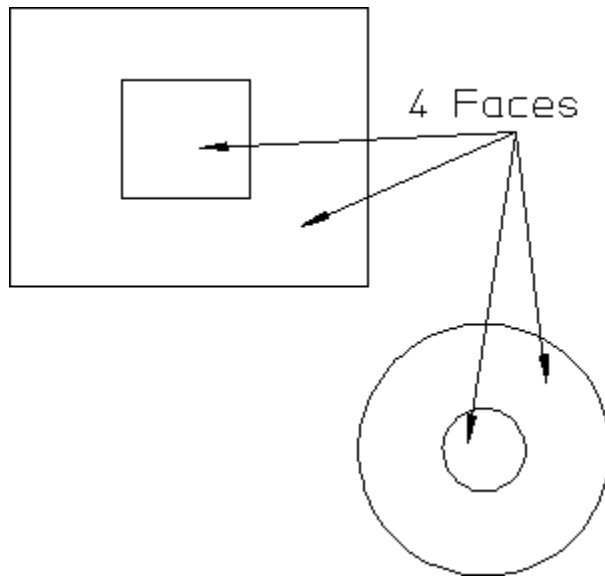

Undoing a Face

You may want to undo a face you have just generated (before specifying the z-value).

The effect of pressing **UNDO** when using the following GEN FACE options is:

- Sing Auto – the last face specified will be removed.
- Singl Manl – during creation of a contour, points will be removed. If you have finished defining a face and have pressed **END**, pressing **UNDO** results in the removal of the entire face.
- All In Prt – all faces generated automatically will be removed.
- With Holes – all faces generated automatically will be removed.

Deleting Covering Faces

This section shows how to delete covering faces. You can delete a single face or all faces in a part. The faces identified must be in the current part and they should not contain any hatching.

A Single Face

To delete a single face:

1. Press **2D HIDDEN LINE**.
2. Pick **DEL FACE**.
3. Identify the face you wish to delete.

Creo Elements/Direct Drafting deletes the face.

All Faces in a Part

To delete all the faces in the current part:

1. Press **2D HIDDEN LINE**.
2. Pick **DEL FACE**.
3. Pick **ALL** in **OPTIONS**.

Creo Elements/Direct Drafting deletes all faces in the current part.

Redrawing in Hidden or Normal Mode

This section shows how to switch between the normal Creo Elements/Direct Drafting redraw function and the hidden line redraw function.

Note

HIDD DRAW affects all WINDOW functions as each takes the z-value information into account.

Hidden Mode

To redraw in hidden mode:

1. Press **2D HIDDEN LINE**.
2. Pick **HIDD DRAW**.
3. Identify the appropriate viewport to use the z-value information when redrawing.

Creo Elements/Direct Drafting displays the drawing partially covered (depending on the z-values associated with the assembly drawing).

Note that Creo Elements/Direct Drafting displays "-H-" in the upper left hand corner to confirm hidden mode.

Normal Mode

This is the default mode. To redraw normally:

1. Press **2D HIDDEN LINE**.
2. Pick **NORM DRAW**.
3. Identify the appropriate viewport.

Coloring Faces

This section shows how to set or change the color of a face.

The FACE COLOR options are:

- Change
- Set
- Reset

Setting/Resetting the Default Face Color

The default face color is dark slate blue on system startup.

To set or reset the default face color given to all newly created faces:

1. Press **2D HIDDEN LINE** and pick MENU 2.
2. Choose from the following:
 - Pick **Set** in **FACE COLOR** and enter an RGB color.
 - Pick **Reset** in **FACE COLOR** to reset the default face color to the background color of the viewport.

Creo Elements/Direct Drafting sets or resets the default face color given to all newly created faces.

One or More Faces

To set, change, or reset the color of a single face or several faces:

1. Press **2D HIDDEN LINE** and pick **MENU 2**.
2. Pick **Change** in **FACE COLOR**.
3. Select from the following:
 - Enter an RGB color.
 - Enter **UNSET** to reset the face color to the background color of the viewport.

-
4. Identify the face(s).

All Faces in a Part

To set, change, or reset the color of all the faces in the current part:

1. Press **2D HIDDEN LINE** and pick MENU2.
2. Pick **Change** in **FACE COLOR**.
3. Select from the following:
 - Enter an RGB color.
 - Enter UNSET to reset the face color to the background color of the viewport.
4. Pick All in OPTIONS.

Viewing a Range of Z-Values

This section shows how to view a range of z-values in your drawing. You can display all elements or only faces (in a color of your choice) that are in a specified range of z-values.

The SHOW LEVELS options are:

- ElemInDrwg
- FaceInDrwg
- ElemInPrt
- FaceInPrt

When you pick the SHOW LEVELS command, the range of z-values input is used in the following way:

- In connection with the options ElemInDwg/ElemInPrt they specify the range of z-values belonging to elements that are visible.
- In connection with the options FaceInDrwg/FaceInPrt they specify the range of z-values belonging to faces that are visible and colored.

Elements in all Parts

Pick **ElemInDrwg** to select all elements:

- In a selected range of z-values.
- In all parts (default).

Elements in Current Part

Pick **ElemInPrt** to select all elements:

- In a selected range of z-values.
- In the current part.

Faces in all Parts

Pick **FaceInDrwg** to select faces:

- In a selected range of z-values.
- In all parts.

Faces in Current Part

Pick **FaceInPart** to select faces:

- In a selected range of z-values.
- In the current part.

Example

To color faces in a particular range of z-values as an aid to visualization:

1. Press **2D HIDDEN LINE**.
2. Pick **HIDD DRAW**.
3. Identify the appropriate viewport.
4. Pick **MENU 2**.
5. Pick **FaceInDrwg** in **SHOW LEVELS**.
6. Enter the lower limit z-value, or pick an element with the lower limit z-value.
7. Enter the upper limit z-value, or pick an element with the upper limit z-value.
8. Enter an RGB color value.

Creo Elements/Direct Drafting displays the selected faces in the required color and does not display those faces with a z-value outside of the desired range. See [Figure 239. Viewing Selected Elements on page 440](#).

Figure 239. Viewing Selected Elements

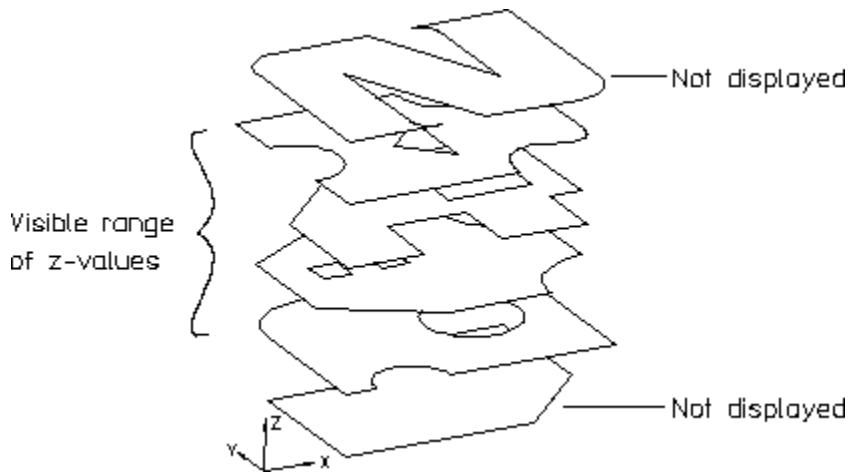

Resetting the Viewport after Viewing

Having used the `SHOW LEVELS` command to display selected elements/geometry you will need to reset the viewport so that you can see all elements/geometry again. To reset the viewport pick `RESET SHOW`.

Generating Hidden Lines

This section shows how to generate hidden lines and load the backup drawing (`workfile.hid`) produced just before generating hidden lines.

When generating hidden lines, Creo Elements/Direct Drafting does the following:

- Geometry is modified by splitting geometric components if they are covered by faces with a higher z-value.
- Shared parts are unshared.
- The parts tree, starting from the current part, will be smashed.

Caution

You are recommended to pick `With Backup` in `GEN HIDDEN` to store your assembly (in `workfile.hid`) before generating hidden lines as this command smashes the parts structure and creates the hidden line geometry.

To generate hidden lines:

1. Press **2D HIDDEN LINE** and pick `MENU2`.
2. Pick **With Backup** or **No Backup** in `GEN HIDDEN`.

-
3. Press **CONFIRM**.

Loading the Backup Drawing

If you wish to recover the backup drawing (`workfile.hid`) produced by picking With Bckup in GEN HIDDEN:

1. Store your hidden line view.
2. Pick **LOAD BCKUP**.

Creo Elements/Direct Drafting will load the original drawing (`workfile.hid`) produced before you generated hidden lines.

Setting How Hidden Lines are Displayed

This section shows how to:

- Switch hidden lines on or off.
- Set the default linetype of hidden lines.
- Change the linetype of hidden lines that already exist.
- Set the default color for hidden lines.
- Change the color of hidden lines that already exist.

The HIDD LINES options are:

- Show On
- Show Off
- Set Color
- Set Type
- Chg Color
- Chg Type
- Rset Color

Setting the Default Hidden Linetype

To set the default hidden linetype:

1. Press **2D HIDDEN LINE** and pick **MENU 2**.
2. Pick **Set Type** in **HIDD LINES**.
3. Press the required linetype in **LINETYPE**.

If not specified, the default linetype for hidden lines is DASHED.

Changing Hidden Linetype

You can change the linetype for any hidden lines you have already computed with GEN HIDDEN.

To change the hidden linetype:

1. Press **2D HIDDEN LINE** and pick **MENU 2**.
2. Pick **Chg Type** in **HIDD LINES**.
3. Press the required linetype in **LINETYPE**.

Setting the Default Color for Hidden Lines

To set the default color for hidden lines:

1. Press **2D HIDDEN LINE** and pick **MENU2**.
2. Pick **Set Color** in **HIDD LINES**.
3. Press the required color in **COLOR**.

Creo Elements/Direct Drafting draws all future hidden lines in the selected color.

If not specified, the default color for hidden lines is the same as that used for the original drawing lines.

Resetting the Default Color for Hidden Lines

To reset the default color for hidden lines to that used for the original drawing lines:

1. Press **2D HIDDEN LINE** and pick **MENU 2**.
2. Pick **Rset Color** in **HIDD LINES**.

Creo Elements/Direct Drafting generates all future hidden lines in the same color as the original drawing lines.

Changing Hidden Line Color

You can change the color of any hidden line you have already computed with GEN HIDDEN.

To change the color of hidden lines:

1. Press **2D HIDDEN LINE** and pick **MENU 2**.
2. Pick **Chg Color** in **HIDD LINES**.
3. Press the required color in **COLOR**.

Switching Hidden Lines On/Off

To switch hidden lines on or off:

1. Press **2D HIDDEN LINE** and pick **MENU 2**.
2. Pick **Show On** or **SHOW OFF** in **HIDD LINES** to display your assembly drawing with or without hidden lines.

Plotting Hidden Lines

It is not possible to plot face colors.

To suppress plotting of hidden lines, you must set the hidden line linetype and color appropriately. Refer to the `PLOT_TRANSFORMATION` command in *Writing Macros with Creo Elements/Direct Drafting*.

Dumping Hidden Lines

You can use the screen dumping commands to produce a copy of your drawing that includes face colors (if you have a color printer). Screen dumps can be made at any stage in the drawing process. Refer to [Plotting Drawings and Dumping Screens on page 519](#).

Hidden Line – Tutorial Example 2

This tutorial example shows one way to create an assembly drawing (`CRANK_ASSEMBLY`) from five individual part drawings. The assembly drawing is then used to demonstrate the various features of the *Creo Elements/Direct Drafting 2D Hidden Line Module*.

Creating the Crank Assembly

First create the individual part drawings. This tutorial assumes that the crank assembly has the following part structure:

```
[*] CRANK_ASSEMBLY [~1] [1:1]
    Nut [~6] [1:1]
    Lever [~5] [1:1]
    Crank [~4] [1:1]
    Joint [~3] [1:1]
    Shaft assembly [~2] [1:1]
```

Your screen displays the assembly drawing shown in [Figure 240](#). `CRANK_ASSEMBLY` on page 444 (without the component names).

Figure 240. CRANK_ASSEMBLY

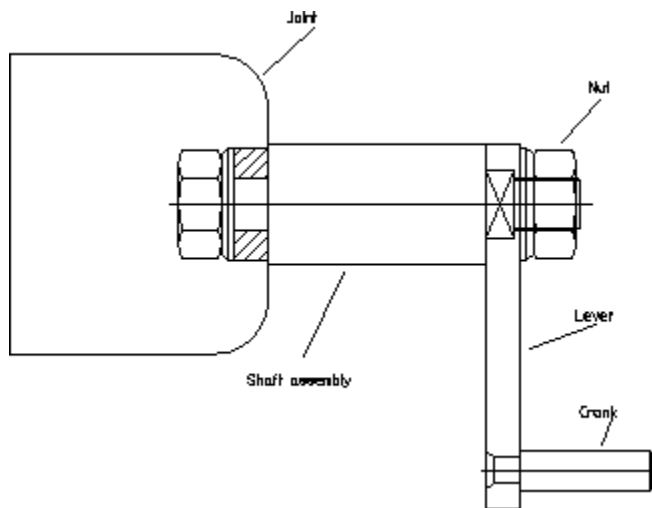

Draw a Cutaway Hole in the Joint

1. Press **PARTS 1**.
Make the Joint the active part.
2. Pick **Part** in **EDIT**.
3. Identify the Joint.
4. Press **CREATE** and pick **SPLINE**.
5. Pick **Closed** in **INTPOL SPL**.
6. Indicate points for the spline to create the viewing hole shown in [Figure 241. CRANK_ASSEMBLY With Cutaway Hole on page 445](#).

Figure 241. CRANK_ASSEMBLY With Cutaway Hole

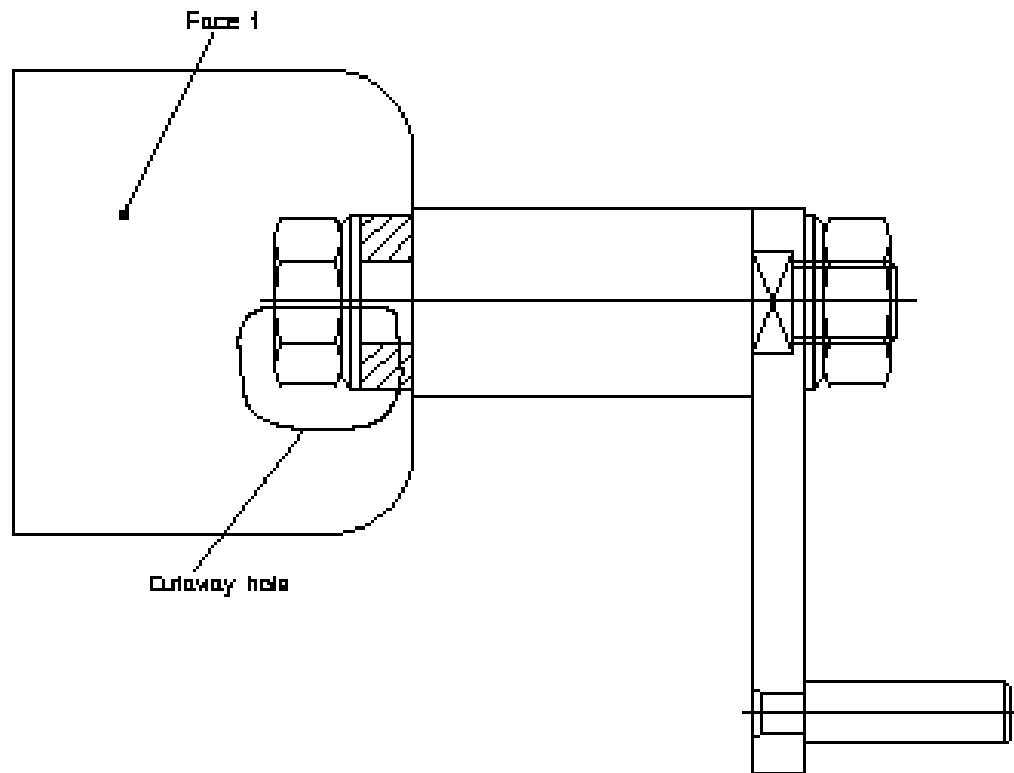

7. Press **END**.

Create Face 1

1. Press **2D HIDDEN LINE**.
2. Pick **HIDD DRAW** and identify the current viewport to get visual feedback while creating faces (the face is highlighted).
3. Pick **Elements** in **SET Z-VAL**.
4. Box the Joint.
5. Enter 1

Creo Elements/Direct Drafting assigns a z-value of 1 to all elements in the box.

6. Press **END**.

Generate Face 1

1. Pick **CURR Z-VAL**.
2. Enter 1

-
3. Pick **Singl Auto** in **GEN FACE**.
 4. Indicate a point on Face 1.
 5. Press **END**.
 6. Press **REDRAW** in **WINDOW**.

Generate Faces in the Nut

1. Press **PARTS 1**.
2. Pick **Part** in **EDIT**.
3. Identify the Nut.
4. Press **2D HIDDEN LINE**.
5. Pick **Elements** in **SET Z-VAL**.
6. Box the Nut.
7. Enter 1

Creo Elements/Direct Drafting assigns a z-value of 1 to all elements in the box.

8. Press **END**.
9. Pick **All In Prt** in **GEN FACE**.
10. Press **END**.
11. Press **REDRAW**.

Generate a Face in the Lever

1. Press **PARTS 1**.
2. Pick **Part** in **EDIT**.
3. Identify the Lever.
4. Press **2D HIDDEN LINE**.
5. Pick **Elements** in **SET Z-VAL**.
6. Box the Lever.
7. Enter 1.

Creo Elements/Direct Drafting assigns a z-value of 1 to all elements in the box.

8. Press **END**.
9. Pick **All In Prt** in **GEN FACE**.
10. Press **END**.

11. Press **REDRAW**.

At this point you would check for any errors you may have made when assigning z-values and generating faces. See [Figure 242. CRANK_ASSEMBLY with Hidden Mode On](#) on page 447.

Figure 242. CRANK_ASSEMBLY with Hidden Mode On

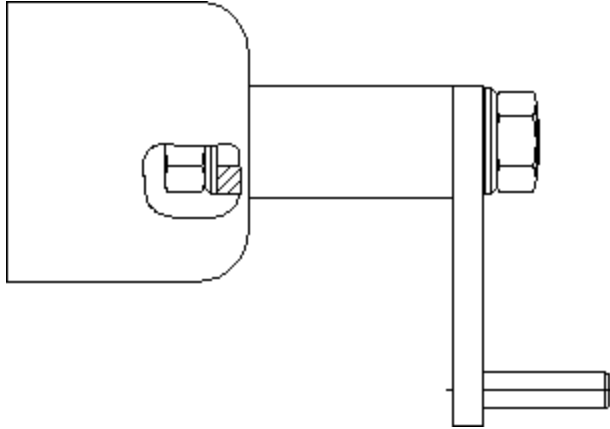

Generate Hidden Lines.

1. Press **PARTS 1**.
2. Pick **Top** in **EDIT**.
3. Press **2D HIDDEN LINE**.
4. Pick **MENU 2**.

Caution

We recommend that you pick With Bckup in GEN HIDDEN to store your assembly (in `workfile.hid`) before generating hidden lines, as this command smashes the parts structure and creates the hidden line geometry.

5. Pick With Bckup in GEN HIDDEN.
6. Press **CONFIRM**.

Creo Elements/Direct Drafting would generate hidden lines as shown in [Figure 243. Cutaway Hole and Hidden Lines](#) on page 448, [Figure 244. Nut — Showing Hidden Lines](#) on page 448 and [Figure 245. Lever — Showing Hidden Lines](#) on page 448.

Figure 243. Cutaway Hole and Hidden Lines

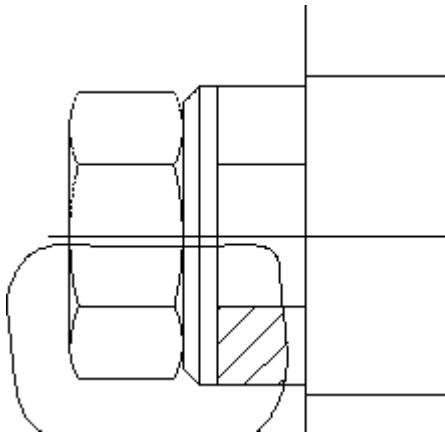

Figure 244. Nut — Showing Hidden Lines

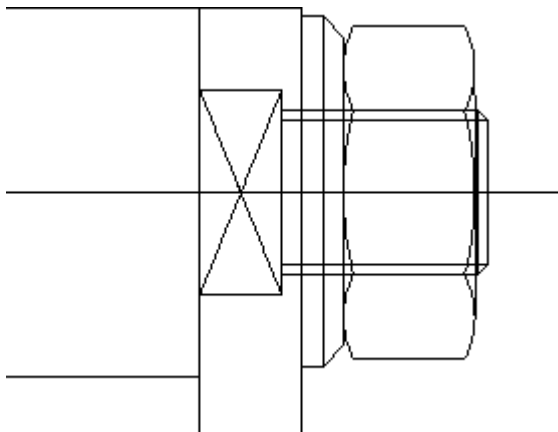
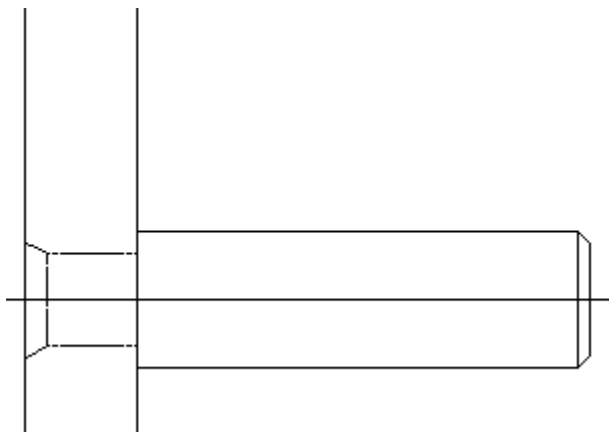

Figure 245. Lever — Showing Hidden Lines



7. Pick Show On or Show Off in HIDD LINES to switch the hidden lines on or off.

14

Using Layers and Infos

Drawing Using Layers.....	450
Setting the Active Layer	453
Duplicating Elements in Other Layers	453
Moving Elements Between Layers	453
Using the Show Block with Layers	454
Modifying and Deleting Layers.....	455
What are Infos?.....	455
Editing an Info	457
Deleting an Info	458
Changing Infos.....	459
Listing Infos	460
Listing Namespaces	460
Using the Show Block with Infos	461
Further Information	461

Drawing Using Layers

The layers commands allow you to split up your drawing into a number of layers. Thus you can place individual elements in a particular layer, or in a number of layers.

The advantage of working this way is mainly in visualization. By switching layers on and off you can simplify what you see on the screen.

Example

Suppose you wish to create an assembly drawing of a cap bearing consisting of four components. Each component was stored as a drawing, and you must load each one to create a four part drawing.

Figure 246. [Cap Bearing Parts Structure on page 450](#) shows the parts structure.

Figure 246. Cap Bearing Parts Structure



Irrespective of the parts structure, you want to be able to see the assembly in three different ways:

- Each of the components individually.
- With the cap removed.
- Fully assembled.

To do this we can use the three layer commands and place the various elements into layers; some elements would be contained in more than one layer.

Finally, using the **LAYER** option in the **SHOW** block you can switch the various layers on and off to produce the required views. The layers would be as follows:

LAYER: 1

Contains all the HOUSING elements.

Figure 247. Layer 1 — Housing Elements

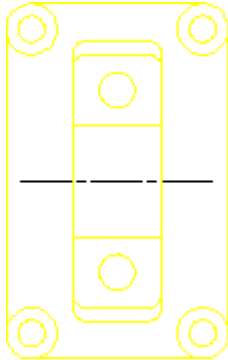

LAYER: 2

Contains all the BEARING elements.

Figure 248. Layer 2 — Bearing Elements

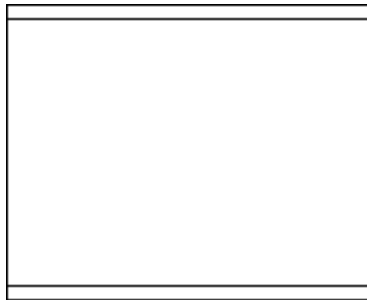

LAYER: 3

Contains all the SHAFT elements.

Figure 249. Layer 3 — Shaft Elements

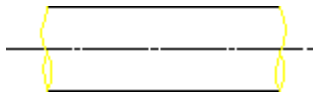

LAYER: 4

Contains all the CAP elements.

Figure 250. Layer 4 — CAP Elements

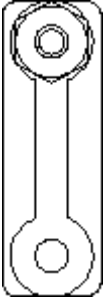

LAYER: 5

Contains most of the HOUSING elements, all the BEARING elements and some of the SHAFT elements.

Figure 251. Layer 5 — Housing, Bearing and Shaft Elements

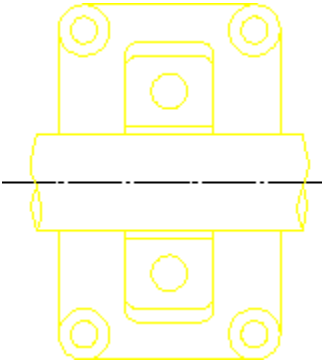

LAYER: 6

Contains some of the HOUSING and SHAFT elements, plus all the CAP ones.

Figure 252. Layer 6 – Housing, Shaft and CAP Elements

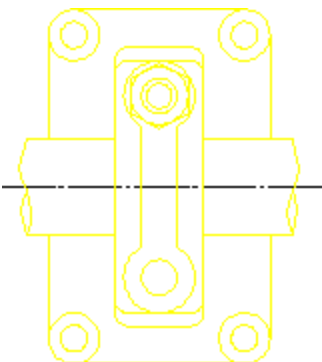

Setting the Active Layer

This section shows how to set any layer active. When a particular layer is active, all subsequently drawn elements will be placed in it.

To set a layer active:

1. Press **CURRENT** in the **LAYER** block.
Creo Elements/Direct Drafting will prompt for a layer number.
2. Enter the desired number and you are ready to start drawing in the layer.

The number of the current layer is displayed in the Current Layer entry in the System Status Line.

Duplicating Elements in Other Layers

This section shows how to duplicate elements contained in one layer in another. After using the function the selected elements will be in both layers. The function can be used irrespective of which layer is current.

To duplicate elements contained in one layer in another:

1. Press **ADD** in the **LAYER** block.
2. Creo Elements/Direct Drafting will prompt for the number of the layer to which elements are to be added.
3. Identify the elements to be added. This can be done in one of two ways:
 - a. Identify or box the elements to be added. This method is most suitable for simple selections of one or two elements.
 - b. Alternatively, press **SELECTION** in the **SELECTION** block and proceed by using the various **SELECTION** options. When identification is complete press **CONFIRM** and Creo Elements/Direct Drafting will add the elements to the selected layer. This method is most suitable for large selections as you can see which elements have been identified so far.

Moving Elements Between Layers

This section shows how to transfer elements from one layer to another. The function can be used irrespective of which layer is current.

To transfer elements from one layer to another:

1. Press **CHANGE** in the **LAYER** block.
2. Enter the number of the layer to which elements are to be transferred.
3. Identify elements to transfer. This can be done in one of two ways:

-
- a. Identify or box the elements to be transferred. This method is most suitable for simple selections of one or two elements.
 - b. Alternatively, press **SELECTION** in the **SELECTION** block and proceed by using the various **SELECTION** options. Once identification is complete, press **CONFIRM** and Creo Elements/Direct Drafting will transfer the elements to the specified layer. This method is most suitable for large selections as you can see which elements have been identified so far.

Using the Show Block with Layers

The SHOW functions enable you to:

- Selectively switch layers on or off.
- Assign a color to each layer.

Showing Layers On & Off

To switch layers on or off:

1. Press **LAYER ON** or **LAYER OFF** in the **SHOW** block.
2. Enter the number of the layer.

Creo Elements/Direct Drafting will now switch the specified layer on or off. In addition to a number, Creo Elements/Direct Drafting will accept wildcards. A full explanation of wildcards is given in [Storing, Loading and Filing on page 462](#).

Three examples using wildcards and the **SHOW** block are given below:

Example 1

Starting with all layers switched on, switch off all layers except layer 4.

1. Press **LAYER OFF** in the **SHOW** block.
2. Enter "*** [! 4]**" (this means all layers except layer 4).

Creo Elements/Direct Drafting will now switch off all layers except layer 4.

Example 2

Switch off all layers:

1. Press **LAYER OFF** in the **SHOW** block.
2. Enter "*****" (this means all layers).

Creo Elements/Direct Drafting will now switch off all layers.

Example 3

Switch on layers 1, 6 and 7:

1. Press **LAYER ON** in the **SHOW** block.
2. Enter " [1 6 7] " (this means layers 1, 6, and 7).

Creo Elements/Direct Drafting will now switch on layers 1, 6, and 7.

Showing Layer Color

You can color a layer to aid visualization. This will not affect plotter pen numbering.

To color a layer:

1. Press **LayerColor** in the **SHOW** block.
2. Enter a layer number.
3. Press a color in the **COLOR** block.

Creo Elements/Direct Drafting will redraw the entered layer in the color.

To recover the original color of the layer, switch the layer on again using the **SHOW ▶ Layer** function.

Modifying and Deleting Layers

There may be occasions when you wish to modify or delete complete layers. In such cases use the **LAYER** option in the **SELECTION** block.

To modify or delete complete layers:

1. Press **MODIFY** or **DELETE**.
2. Press **SELECTION** in the **SELECTION** block.
3. Press any **SELECT** option.
4. Press **LAYER**.
5. Enter the layer number using wildcards if necessary.
6. Press **CONFIRM** and you are ready to continue with the command.

What are Infos?

The major components of a drawing are drawing elements such as lines, circles, arcs, and so on. Each element is stored in memory together with information to describe it. These pieces of information attached to each element are known as attributes.

Examples of attributes are an element's linetype and color. In addition to these, Creo Elements/Direct Drafting allows you to enter your own attributes, called Infos.

An info is simply a piece of text attached to an element. The info is not visible on the screen, but is attached to the element in memory. The use of infos is a matter of personal or company preference. They can be used to:

- Store information concerning a design update. The revised elements could all have the following infos added to them:

Revision number:003

Nature of revision: Dimensional changes to accommodate updated bearings

- Store information concerning dates and names:

Designer: Bill G

Date: 03.03.93

Job No: 147/2

In addition to whatever use you make of infos, Creo Elements/Direct Drafting uses them during the Layers commands. Thus if you place an element in layer 1, Creo Elements/Direct Drafting will attach the info `LAYER: 1` to it.

Press the **INFO** block. The INFO menu will appear, containing the following commands:

- ADD SELECT
- ADD CURRNT
- DELETE
- EDIT
- CHANGE
- LIST

Adding Infos

This section shows how to add infos to drawing elements. The ADD SELECT options are:

- Element
- SCREEN

To Existing Elements

To add infos to existing drawing elements:

1. Press **INFO**.
2. Pick Element in ADD SELECT.

-
3. Enter the info text.

This can be done in one of two ways:

- Enter the required text enclosed in quotes (' ' or " "). This is the best method to use for infos of up to one line in length.
- Alternatively, pick SCREEN. The screen will clear and you can type in and edit the info text. Don't enclose the text in quotes. When you have finished typing the info, press [Ctrl] [D]. The screen will reappear and you are ready to continue the command.

Once the info text has been entered, you can add it to any existing elements.

4. Identify the required elements and the system will add the info to them. Alternatively, you can use the **SELECTION** block in the normal way to identify elements.

Adding the Current Info

You can create infos as current such that they are attached to all subsequently drawn elements:

1. Press **INFO**.
2. Pick ADD CURRNT and enter the info text. This can be done in one of two ways:
 - a. Enter the required text enclosed in quotes (' ' or " "). This is the best method to use for infos of up to one line in length.
 - b. Alternatively, pick SCREEN. The screen will clear and you can type in and edit the info text. Don't enclose the text in quotes. When you have finished typing the infos, press [Ctrl] [D] on the keyboard. The screen will reappear and you are ready to continue.

Once the current info has been set, you can continue drawing. All new elements will automatically contain the current infos.

Editing an Info

This section shows how to edit any existing info.

The command options are:

- Element
- Current

An Existing Element

To edit the info for any existing element:

1. Press **INFO**.
2. Pick Element in EDIT.
3. Identify the drawing element to be edited.
The display will clear and be replaced by the infos belonging to the element.
4. Edit the text using the edit keys and keyboard.
5. When you have finished editing, press [Ctrl] [D] and the normal display will return.

The Current Info

To edit the current info:

1. Press **INFO**.
2. Pick Current in EDIT.
The normal display will clear and be replaced by the current infos.
3. Edit the text using the edit keys and keyboard.
4. When you have finished editing, press [Ctrl] [D] and the normal display will return. All newly drawn elements will contain the revised current infos.

Deleting an Info

This section shows how to delete existing infos or the current info.

The command options are:

- Element
- Current

An Existing Info

To delete the infos belonging to any existing drawing elements:

1. Press **INFO**.
2. Pick Element in DELETE.
3. Identify elements. This can be done in one of two ways:
 - a. Identify individual elements or use a box to identify several. The system will now delete the infos.

-
- b. Alternatively, press **SELECTION** in the **SELECTION** block and proceed by identifying elements using the various **SELECTION** block options. When identification is complete, press **CONFIRM** and the system will delete the infos.

The Current Info

Pick Current in DELETE and Creo Elements/Direct Drafting will delete the current info. If you now continue drawing, all new elements will be without infos.

Changing Infos

This section shows how to change infos.

The command options are:

- Element
- Current
- Global

For each option enter the line of info text to be changed, and the new text. You can use wildcards (that is, *, ?, [. .], ! and \) in either the info text to be changed, or the new text.

For further information about wildcards, refer to [Storing, Loading and Filing on page 462](#).

An Existing Info

To change any existing info:

1. Press **INFO**.
2. Pick Element in CHANGE.
3. Enter the line of info text to be changed.

For example, "DRAWN ON 28.02.93".

4. Enter the replacement text.

For example, "DRAWN ON 03.03.93".

Now identify the elements to be changed. This can be done in one of two ways:

- Identify individual elements, or box several elements.

Creo Elements/Direct Drafting changes the info text for the identified elements.

-
- Alternatively, press **SELECTION** in the **SELECTION** block and proceed by identifying elements using the various **SELECTION** block options. When the identification is complete, press **CONFIRM** and Creo Elements/Direct Drafting will change the elements.

The Current Info

To change the current info:

1. Press **INFO**.
2. Pick Current in CHANGE.
3. Enter the line of the current info to be changed.
4. Enter the replacement line and the system will change the current info.

Once the change is made, you are ready to continue drawing. The revised current info will be added to all new drawing elements.

All Occurrences

To perform changes to all occurrences of an info:

1. Press **INFO**.
2. Pick Global.
3. Enter the line of info text to be changed.
4. Enter the replacement line and the system will change every such occurrence without you having to identify elements.

Listing Infos

This section shows how to produce a list of all infos used in your drawing.

1. Press **INFO**.
2. Pick LIST and a list of all infos used in your drawing will appear on the screen.
3. Press [Ctrl] [D] to return to the normal screen.

Listing Namespaces

Namespaces are used for structuring infos. The use of namespaces in Creo Elements/Direct Drafting enhanced performance through targeted inquiries. For further details, refer to Infotext namespace in the Creo Elements/Direct Drafting Help.

To list all of the namespaces currently in use:

1. Press **NAMESPACES** in **INFO**. All namespaces used in your drawing (for example, SYS:HL_SCOPE includes Z-LEVELS) are displayed in an Info Browser.
2. Close the Info Browser to return to the normal Creo Elements/Direct Drafting display.

Using the Show Block with Infos

The **SHOW** options that can be used with infos are:

- **SHOW INFO ON**
- **SHOW INFO OFF**

Using Show Info On and Off

To switch elements containing a certain info on or off:

Press the required option in the **SHOW** block and enter the info text.

Creo Elements/Direct Drafting will now switch on or off all elements containing the info text you have entered.

Further Information

For further technical information about layers and infos, refer to the Creo Elements/Direct Drafting help system:

Enter `help layers` or enter `help infos` at the Creo Elements/Direct Drafting command line.

The screen will clear and Creo Elements/Direct Drafting will display further information about layers or infos.

15

Storing, Loading and Filing

File Organization and Names	463
Identifying Files	464
Loading and Storing Drawings Using File Browser	466
Importing a Bitmap File	471
Transparency	475
Loading a Drawing or Part (Filename Method)	477
Storing a Drawing (Filename Method)	480
Creating a New Creo Elements/Direct Drafting Instance	483
Opening an Existing Drawing File in a New Creo Elements/Direct Drafting Instance	483
Viewing the Catalog	484
Listing Catalog Items	485
Sorting the Catalog	489
Selecting the Current Directory	491
Copying Files and Directories	492
Purging Files or Directories	496
Creating Directories	500
Editing Files	500
Inputting Files	501
Saving Files	501

Press the **FILE** block to display the main filing commands. Press **FILE** to access less frequently used commands (you can also access this menu by picking MENU 2 in **FILE**).

File Organization and Names

This section gives a brief overview of file handling terminology, sufficient to use the **FILE** module.

All file access operations can easily be performed using Creo Elements/Direct Drafting filing commands.

File Organization

A file is simply a container into which you can put data. The most important aspect of a file is that it has a name which you have allocated to it. The contents of a file can be displayed, copied, and removed from the system.

A directory is a file containing information about other files and directories. A directory contained within another directory is called a subdirectory, and each subdirectory can itself contain files and more subdirectories. [Figure 254. File System Hierarchy on page 463](#) shows file system hierarchy.

Figure 254. File System Hierarchy

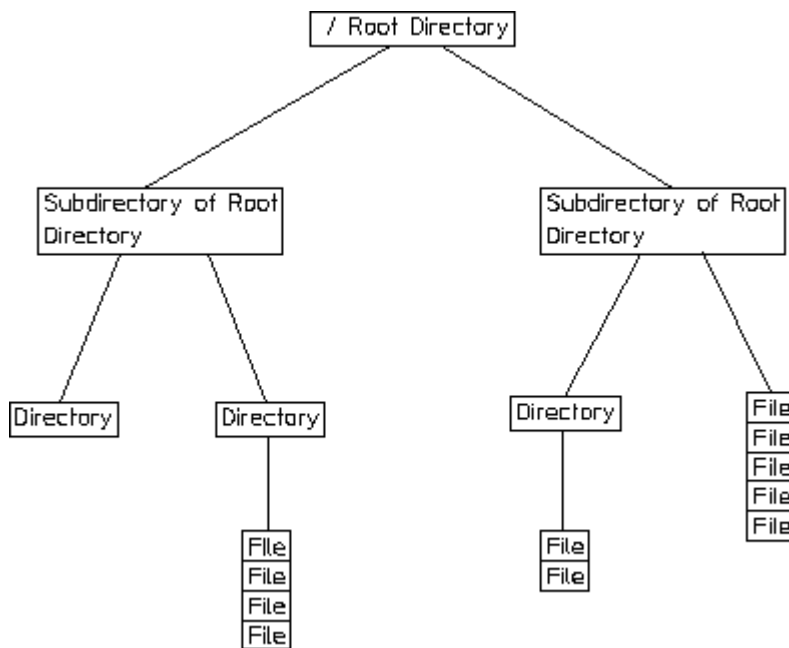

Filenames

In theory, a filename can consist of any characters available on the keyboard. As a general rule, it is best to restrict yourself to names consisting of letters, digits, underscore characters and the period (provided it is not used at the beginning of filenames). Blank spaces should not be used as filenames.

Identifying Files

This section shows how to identify files to ensure the correct file is loaded, stored, and so on.

You can identify files three ways:

- Using the `FBROWSER` command (see [Loading and Storing Drawings Using File Browser on page 462](#) later in this chapter).
- With the file path name.
- With the **CURR DIR** (current directory) command in **FILE**.
- With the `SEARCH` command.

Using the File Path Name

The file path name consists of the directory path and filename, all separated by a forward slash (/). Suppose you wish to perform a file command on the following:

Filename: `my_macro`

In directory: `macro_dir`

In directory: `larry`

In directory: `users`

In directory: `/` (root directory)

To identify the file you would enter the following string:

```
'/users/larry/macro_dir/my_macro'
```

[Figure 255. Directory/File Structure on page 464](#) shows the directory/file structure.

Figure 255. Directory/File Structure

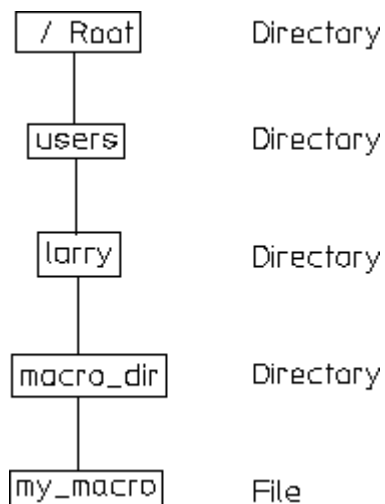

Using the Current Directory Command

The CURR DIR command allows you to set a default file path for all filing commands. This means that each time a filename is entered, Creo Elements/Direct Drafting will look for the file in the current directory. You normally set the current directory to your own user directory so that file commands can be performed quickly within it. Suppose your current directory was previously set to:

```
 '/users/larry'
```

and you wish to perform a file command on:

```
 '/users/larry/nvb_drw_101'
```

all you have to enter is:

```
 'nvb_drw_101'
```

Using the Search Command

The SEARCH command allows you to specify further directories, other than the current directory, to be searched during the LOAD and INPUT commands. Use this command to quickly load macros, standard parts and so on contained in other directories.

To search directories:

1. Press **SETUP**.
2. Pick **EDIT ENV**.
3. Enter the directory name to be searched below the SEARCH entry within the file.

For example, suppose that the directory `'/users/system_macros'` is to be searched for the file `ansi_macros`. If the following had been entered into the search command:

```
SEARCH  
'/users/system_macros'  
END
```

all you would have to enter is:

```
 'ansi_macros'
```

Multiple search paths can be included:

```
SEARCH  
'/users/system_macros'  
'/users/parts_bolts'  
'/users/common/work_comp'  
END
```

Loading and Storing Drawings Using File Browser

You can load and store drawings quickly and easily by selecting the file from the FILE BROWSER window. You do not need to remember long filenames and subdirectories as these are displayed. (You can still enter the filename on the command line if you wish.)

You can also tell Creo Elements/Direct Drafting to close the file-browser window once the drawing is loaded or to leave it open for further selections.

The following file formats can be loaded in Creo Elements/Direct Drafting:

- Model Interface Standard (*.mi)
- Compressed MI (*.bi) (compressed by means of the Z-lib mechanism)
- Autodesk Drawing Interchange (*.dxf)
- Initial Graphics Exchange Format (*.igs)
- AutoCAD File Specification (*.dwg)
- Creo Elements/Direct Drafting bundle files (*.bdl) (Note that only the 2D portions of such files are extracted, while any 3D portions are ignored.)
- HPGL and HPGL2 files (see loading HPGL format files)
- All files

To load a drawing using the file browser method:

1. Press **FILE**
2. Pick **Drw/Part** in LOAD
3. Pick **FBROWSER**
4. Pick the desired directory from the Directories window
5. Pick the desired file from the Files window

The file is highlighted.

6. Either pick OK or pick the highlighted file again

If you specified the option Keep, the browser windows remain open and you can pick Drw/Part again to load additional drawings. If you specified No Keep, the browser window closes when the drawing is loaded.

To store a drawing using the file browser method:

1. Press **FILE**
2. Pick STORE
3. Pick Delete Old
4. Pick FBROWSER

5. Pick the desired directory from the Directories window
6. Pick the desired file from the Files window
 - The file is highlighted.
7. Either pick OK or pick the highlighted file again

Figure 256. The File Browser Menus

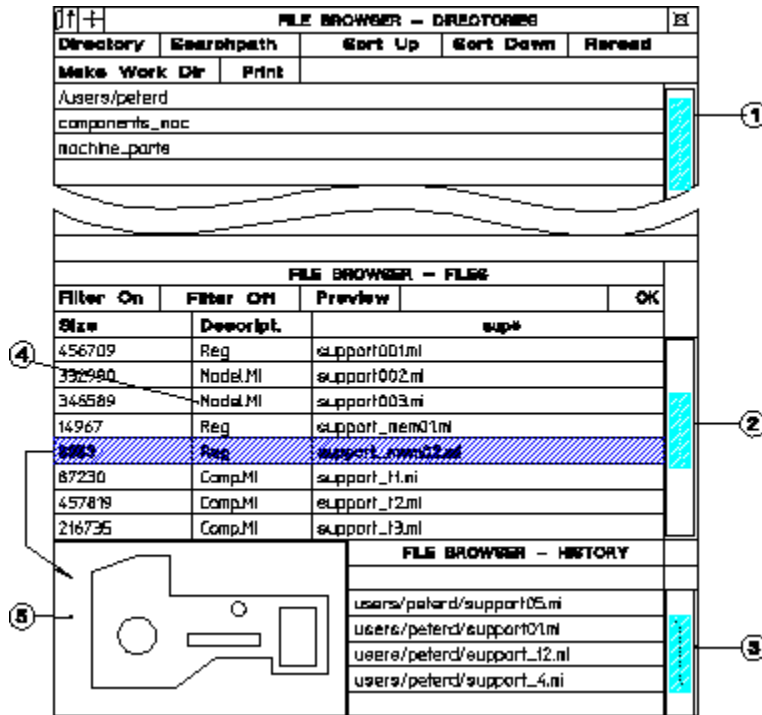

- 1 Directory list
- 2 Files in the current directory
- 3 Most recently loaded files (up to 16 from last session)
- 4 File format showing compressed and uncompressed formats
- 5 Preview image of drawing

Other features include:

- The number of displayed rows is 10.
- The file browser can be pinned by click on the icons in the top left corner.

Listing Compressed MI Files

The File Browser indicates which files are compressed MI files. These are shown as `Comp.MI` in the `Descript.` column. Uncompressed MI files are indicated by `Model.MI`.

Printing the File Browser

The Print command in the File Browser lets you to print the contents of the current directory to a file. The result is an ASCII file in tabular format, similar to the following:

List of directories :

```
..
support
```

List of files :

File Name	Size	Descript.
Created Modified		
=====	=====	=====
dd082001.mi	3466	Model.MI 27-
Sep-99 2-Oct-99		
dd102001.mi	3382	Model.MI 27-
Sep-99 27-Sep-99		
dd102002.mi	5185	Model.MI 27-
Sep-99 27-Sep-99		
dd152001.mi	9341	Model.MI 27-
Sep-99 27-Sep-99		
dd152003.mi	56009	Model.MI 30-
Sep-99 17-Oct-99		

Scrollbar Position

When you display the File Browser, the position of the scrollbar in the FILE BROWSER - FILES table is frozen at the last-opened position. This becomes the new starting point for scrolling.

Working Directory

You can change to the working directory by clicking the Work Dir button in the File Browser.

The working directory is specified by the environment parameter ME_WORKING_DIR. If this parameter is not specified, the default value is used (\temp on Windows-based systems). It is implemented in the same way as the MEDIR parameter.

The following example specifies the working directory to be project-orion:

```
....
MEDIR=/users/rayh/me10.80/me10
ME_WORKING_DIR=/users/rayh/project-orion
MELOCATOR=xlocator
....
```

The next time you select Work Dir in the File Browser, Creo Elements/Direct Drafting changes the current directory to `project-orion`. If the directory does not exist, Creo Elements/Direct Drafting issues an error message.

History Table

The File Browser now includes the HISTORY table displaying all files loaded in current Creo Elements/Direct Drafting session. It is displayed below the FILES table. The highlighted entry is the currently displayed drawing. Clicking on an entry does the following:

Double-Click Selected file name to be sent to the user input line as input and the drawing is loaded.

- The file at the top of the list is the last file to be loaded (order is from top to bottom).
- The display name of the history table is `FBT_HDTAB`.
- If you load a drawing or part via the File History menu, the part is loaded below the top part.

Previewing Drawings

When you store a drawing, you can also specify whether or not to create a preview image of the drawing. This image is displayed in the File Browser window to let you preview a drawing before loading it. This saves time when you cannot remember the filename of the drawing. Drawings can only be previewed if they were previously saved with the preview option set to on (this is set in the SETUP 1 menu, see [Setting the Preview Mode on page 28](#)).

Note

The previewed drawing is a pixel-based image and cannot be modified.

To preview a drawing:

1. With the File Browser displayed, click Preview
2. Select the file to preview (you can also enter the filename on the user input line)
3. Click OK

Creo Elements/Direct Drafting displays the drawing in the preview window. To load this drawing, click Drw/Part in LOAD and click on the highlighted file.

Exporting a Bitmap (Pixmap)File

You can output your drawings in high-resolution pixel format:

1. Click **File**
2. Click **Export**
3. Follow **Bitmap to File** across and choose an option:
 - BMP
 - JPEG
 - PNG
 - TIFF
4. You will be prompted through the rest of the export.

Prompts are:

Enter `PORT`, `BOX`, `DEL_OLD` or "destination" — to select input

- Enter `point`, `CURRENT` or viewport number — to further select after `PORT`
- Enter lower left and upper right corner of box which is to be dumped — to select after `BOX`

Enter `RESOLUTION` or "destination"

- Enter `PAPER_TO_PIXELS` or output image width, height — if you select `RESOLUTION`
 - `PAPER_TO_PIXELS` - recalculates paper format and dpi to your X,Y resolution. You will be prompted for a paper format (A-E, A4-A0) or size, and then you will be prompted for dpi.
 - Enter output image width, height - enter width and height in pixels. Enter -1 for either width or height to retain the ratio of the current viewport and specify the other dimension in pixels.

Possible error messages are:

- Not enough memory available to perform the operation.
- ***The output image size is limited to a maximum of 4/3 billion pixels.

Using the File-Browser Options

Creo Elements/Direct Drafting's file browser lets you set various options to search, sort, and set filters.

Directory	Displays list of directories/subdirectories
Searchpath	Displays list of searchpaths to be searched

Sort Up	Sorts the catalog such that all entries are sorted on filesize with the smallest appearing first.
Sort Down	Sorts the catalog such that all entries are sorted on filesize with the biggest appearing first.
Reread	Updates the window
Filter On	Switches on filtering
Filter Off	Switches off filtering

To set a pattern, pick the field marked with an asterisk (*) and enter the pattern on the command line.

Scrolling

Tabular screens such as the File Browser includes a scrollbar to let you quickly scroll through tables.

Figure 257. Scrolling the File Browser

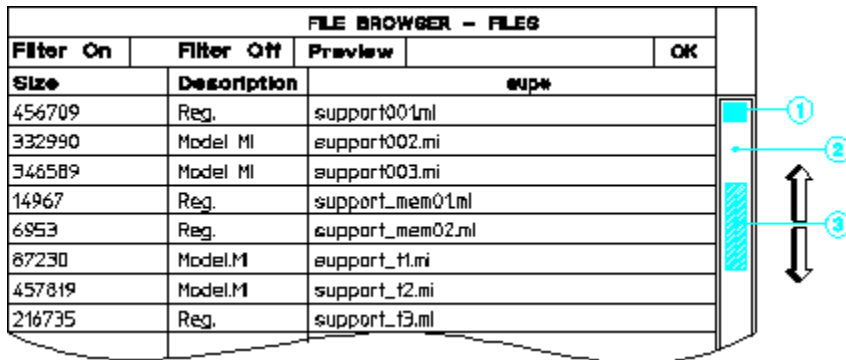

- 1 Click here to scroll to the next page
- 2 Click here to scroll to the next line
- 3 Click and drag the scrollbar

Note

All existing tables will get this scrolling feature automatically.

Importing a Bitmap File

Creo Elements/Direct Drafting lets you import bitmap files in TIFF (*.tif, compressed and uncompressed), BMP (*.bmp) and JPEG (jpg) formats. The following TIFF compression methods are supported:

- Packbits

-
- CCITT Group 3 1-Dimensional (modified Huffman encoding)
 - CCITT Group 4

Being able to import images is particularly useful when you want to place a scanned image onto your drawing or include a 3D model for better visualization.

Importing a Bitmap File

To import a bitmap file:

1. Click **Drw/Part** in **FILE 1**
2. Click **FBROWSER**
3. Highlight the file
4. Click **OK** in **FBROWSER**

All images currently loaded are listed in the picture browser together with a flag to indicate whether they are hidden or not.

Creo Elements/Direct Drafting provides a Picture Browser for imported images.

Deleting an Image

To delete an image, click **DELETE** on the main menu, then click the image.

Moving an Image

To move an image, click **MOVE** in the **MODIFY 1** menu.

Rotating an Image

To rotate an image, click **ROTATE** in the **MODIFY 1** menu.

Scaling an Image

To scale an image, click **SCALE** in the **MODIFY 1** menu.

Arranging Images

To arrange images, click **To Back** or **To Front** in the **PICTURE** menu.

Hiding and Showing Images

To improve system performance, images can be hidden with the **SHOW PICTURES** command. If the drawing includes several images, you can choose to hide individual images or all images. The **SHOW** options are:

On	Unhides a hidden image
Off	Hides an image
Box	Hides an image but places a reference frame around the hidden image

 **Tip**

When zooming with the dynamic mouse ([Ctrl] + right mouse button), hide the images with the Box option.

Quality

When large drawings are placed on a small screen, some pixels from the original drawing cannot be shown. Two or more pixels from the large drawing must be mapped into one destination pixel on the screen. Traditionally, this operation meant that small lines and details could disappear.

Creo Elements/Direct Drafting provides aliasing to let you control quality-time trade-offs of large drawing displays. Aliasing algorithms establish an area of investigation in the large drawing; formulas compute an average color tone for that area; and the system maps that color result to the destination pixel. Areas of investigation are based on one pixel and a pattern of its neighbors. Color tone result is grey-scale, an average of the original black and white pixels.

To control display quality using aliasing:

1. Click **ANTI-ALIAS** in the **PICTURE** menu.
 - a. Specify picture quality number. Enter a number between -2 and +2.
 - b. Select pictures for which to apply the change.

Positive input between **0** and **2** tells the system to use a block of converging pixels in the aliasing formula. Input **2** to use the largest possible block of neighboring pixels. This results in the slowest possible operation.

Input **0** to produce the fastest operation. No aliasing.

Negative input between **0** and **-2** tells the system to use pixels on a diagonal in the aliasing formula. This option is much faster than using blocks, and often produces a picture of good quality. Input **-2** to use the largest number of neighboring diagonal pixels in the aliasing formula.

Changing the Color of Pixels

After you have imported an image, you probably want to clear unwanted information or simply clean it of the debris usually associated with scanned images. This is done by changing the color of the pixel data. If the image is black and white, you can only reverse the color (black to white or white to black). Changing the color of individual pixels to the background color of the image appears to delete the pixel. However, you have only colored the pixel. It is not possible to delete pixels in order to see through to an underlying image.

Figure 258. Cleaning an Imported Image

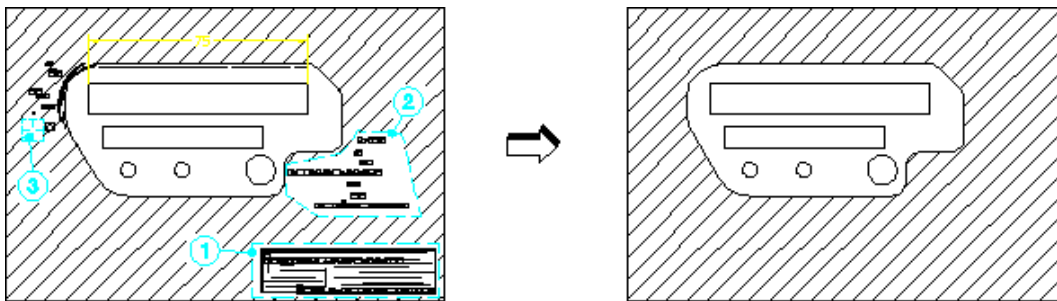

You can cleanup or edit an image with the following CHG COLOR options:

- 1 Box option
- 2 Poly option
- 3 Brush option

To change the color of pixels:

1. Click **CHG COLOR** (**PICTURE** menu)
2. Identify the image
3. Select one of the following options:
 - Box — and enclose the required pixels in a box
 - Poly — and enclose the required pixels in a polygon
 - Brush — press and hold down the [Shift] key while dragging the cursor over the pixels to be colored (the cursor changes shape)
4. Click **END** to end the command

Additional Information:

- If the Brush color is different to the background color, you can add or red-line information on the image.
- The image is always described by a rectangular frame. If you rotate the image, the frame increases/decreases according to the horizontal and vertical lines passing through the corners, see [Figure 259 on page 462](#). The swept area is

only temporary – it disappears along with any pixel editing you may have done.

Figure 259. Rotating an Imported Image

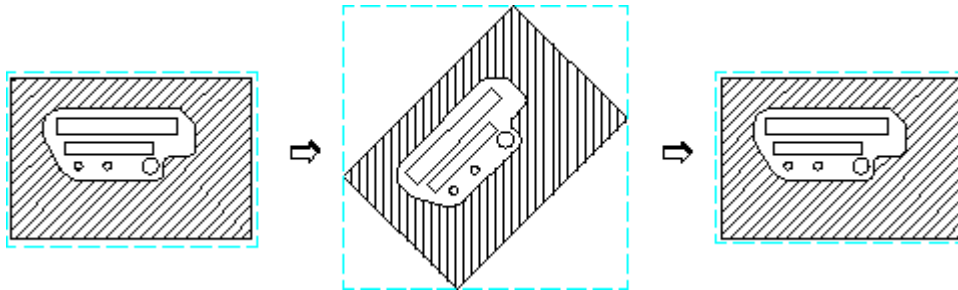

Modify

Inverting Black and White in Images

To invert black and white in an image:

1. Click **B&W Invert** in the **PICTURE** menu.
2. Select the image in which you want to change black to white and white to black.

Transparency

You can select one color in your picture to become transparent when that picture overlays another picture. The color you select for transparency becomes invisible, allowing you to see through those pixels to the lower picture.

To set transparency attributes:

1. Click **TRANSPAR** in the **PICTURE** menu.
2. Select a transparency option:
 - **On** — Prompts you to select a picture. If that picture has a transparency color, the color will become invisible during overlay.
 - **Off** — Prompts you to select a picture. If that picture has a transparency color, the color will not become invisible (default setting).
 - **Color** — To select a picture and apply the transparency color you have chosen from the color menu to it.

 **Note**

Transparent pixmap attributes must be set by Creo Elements/Direct Drafting. Attributes from other programs such as those written in jpg, tiff, etc. will not be supported. All imported files will be opened as not transparent.

Using the Picture Browser

To display the Picture Browser:

1. Click **PICTURE**.
2. Click **P BROWSER**.

Creo Elements/Direct Drafting displays the **PICTURE BROWSER**. This browser displays information about the currently loaded images:

Pixmap Name	Filename and path of the image
Z-val	Z-value: Numerical value assigned to an image to position it in the drawing
Show	Status of the SHOW command; ON, OFF, or BOX
X-scl	Scaling factor in the x-direction
Y-scl	Scaling factor in the y-direction
Angle	Angle of rotation
OUTPUT	Prints image information to a file, screen, or a printer (you can use the options Delete Old or Append)

Additional Information

- The imported graphic is embedded in the MI file format. In the MI file the pixel data will be handled in a special section as ASCII characters.
- The imported image maintains its aspect ratio.
- If two images overlap each other, the options in EDIT can be used to move the image forwards or backwards. Click in a non-overlapping area to select the image. Alternatively, enter the name on the user input line.
- If a drawing geometry overlaps an image, it is placed at the front of the image (s).

 **Tip**

Change the color of the overlapping geometry.

- Plotting of images is supported by raster-based plotters only (for example, plotters supporting PostScript or HP-GL/2 plus RTL). Images are ignored on non-supported plotters.
- IGES and DXF/DWG translators do not translate pictures by default and report a warning message in the log file when pictures are skipped.
- The Store Pixel Data switch in the IGESo.conf file allows storage of picture to separate files.
- When an pixmap is loaded, the size of the pixmap (in current units) is determined by the factor (current_viewport->factor which is number of current units per pixel). Hence the actual size of the image depends on the current value of the zoom factor.
- When an image with more colors than supported by the hardware is loaded and subsequently saved, loss of color occurs. For example, if an image containing 1500 colors is loaded on an 8-bit machine (which can display only 256 colors) and saved, only 256 out of the 1500 colors are saved in the MI file. (The pixels with the lost colors are mapped to the nearest available color in the color table.) This changes the size of the MI file once a load and save is done across different platforms (with different number of bitplanes) without any deletion of data (image contents) in the file.

Loading a Drawing or Part (Filename Method)

This section shows how to load a drawing or part. The LOAD options are:

- Drw/Part
- Subpart
- 'workfile'

Loading a Drawing

This is the default option.

To load a drawing:

1. Press **PARTS 1**.

-
2. Pick **Top** in **EDIT**.
 3. Press **DELETE**, **ALL**, and **CONFIRM**.
 4. Press **FILE**.
 5. Pick **Drw/Part** in **LOAD**.
 6. Enter the name of the file to be loaded. For details of acceptable filenames, refer to [File Organization and Names on page 462](#).

Creo Elements/Direct Drafting loads the drawing.

Loading a Part

In the case of an assembly drawing, a part is loaded beneath the top part. This means that there is no need to clear the memory as the top part has now been renamed, for example

EXAMPLE_ASSY

.

To load a part:

1. Press **FILE**.
2. Pick **Drw/Part** in **LOAD**.
3. Enter the name of the file to be loaded. For details of acceptable filenames refer to [File Organization and Names on page 462](#).
4. Position the reference point of the loaded part relative to the drawing's coordinate system. This can be done in two ways:
 - a. Indicate the desired location of the part's reference point with the cursor.
 - b. Or pick **ABSOLUTE** in **FILE**.

Creo Elements/Direct Drafting will automatically load the part into the position, relative to the origin, in which it was originally created.



Note

Creo Elements/Direct Drafting loads the file immediately beneath the top part.

Loading a Subpart

You can load a part file under the active part, as a subpart.

To load a subpart:

1. Press **FILE**.

-
2. Pick **Subpart** in **LOAD**.
 3. Enter the name of the file to be loaded. For details of acceptable filenames, refer to [File Organization and Names on page 462](#).
 4. Position the reference point of the loaded part relative to the drawing's coordinate system. This can be done in two ways:
 - a. Indicate the desired location of the part's reference point with the cursor.
 - b. Or pick **ABSOLUTE** in **FILE**.

Creo Elements/Direct Drafting automatically loads the part into the position, relative to the origin, in which it was originally created.

 **Note**

Creo Elements/Direct Drafting loads the file as a part. The part belongs to the active part and is placed under it in the parts hierarchy.

Loading a Workfile

You will need to load the workfile if for some reason you have lost or corrupted your drawing.

If you need to load the workfile to recover your drawing, you will have lost the work done since the last **STORE 'workfile'** command.

 **Note**

To save your drawing, pick 'workfile' in **STORE** regularly.

To load the workfile:

1. Press **DELETE**, **ALL**, and **CONFIRM** to clear the screen.
2. Press **FILE**.
3. Pick **LOAD** followed by '**workfile**'.

Creo Elements/Direct Drafting will load the file '`workfile`' from the current directory.

Loading an HPGL File

To load an HP-GL or HP-GL2 file:

1. Press **FILE**.

2. Pick **LOAD HPGL**.
3. Enter the name of the HP-GL or HP-GL2 file to be loaded.
4. Position the loaded file in you drawing.

Storing a Drawing (Filename Method)

This section shows how to store a drawing or part in a file. The STORE command stores the file in compressed model interface (MI) format or in uncompressed model interface format. Storing using uncompressed MI format is faster than storing using compressed MI format. However, uncompressed MI format uses considerably more disk space.

STORE has the following options:

MI	Stores the drawing in uncompressed MI format.
Comp. MI	Stores the drawing in compressed MI format (*.bi file, compressed by means of the Z-lib mechanism).
DXF	Writes a DXF (Autodesk Drawing Interchange) file.
DWG	Writes a DWG (AutoCAD File Specification) file.
DWF	Writes a DWG (Drawing Web Format) file.
IGES	Writes an IGES (Initial Graphics Exchange Format) file.
VRML	Writes a VRML (Virtual Reality Modeling Language) file.
SVG	ScalabelVector Graphics (based on XML)
ASCII	Text file (d
MI	Version 2.9 (done with the STORE 290 command).
MI	Version 2.8 (done with the STORE 280 command).
MI	Version 2.7 (done with the STORE 270 command)
MI	Version 2.6 (done with the STORE 260 command).

If you store an MI file, you also have the option of storing the fonts you used to create the drawing text. While this adds to the size of the file, it ensures that anyone else opening your file will see your text. To do this, specify `ADD_FONTS` when you STORE your drawing.

When loading a non-MI file, Creo Elements/Direct Drafting automatically converts the file to MI format. This is done in the background and requires no user interaction. Any errors are recorded in a log file.

 **Note**

The environment variables DXFDIR and IGESDIR must be set to the directories where the translators are kept.

When the translation is complete, check the logfiles (EDIT_FILE filename) for any errors.

Storing Compressed MI Format

This is the default option.

To store the current drawing.

1. Press **FILE**.
2. Pick **STORE**.
3. Enter the name of the file. For details of acceptable filenames refer to [File Organization and Names on page 462](#).

Creo Elements/Direct Drafting will now store the drawing in the named file.

If you want to overwrite an existing file, use the option Delete Old. Pick STORE followed by Delete Old and proceed as normal. Creo Elements/Direct Drafting will store your current drawing and overwrite the existing contents of the named file.

When the Delete Old option is used, the old file will be deleted before the new file is written to the disk. However, Creo Elements/Direct Drafting does not check whether the new file can be written to the disk without error. In certain cases your file could be lost. For example, when:

- The disk is full.
- A power failure occurs.
- A Creo Elements/Direct Drafting error occurs.

The chance of this happening is minimal. However, if you suspect that your disk does not contain enough space for your new file, store the new file first. Use a different filename, and then delete the old file. Power failures, and Creo Elements/Direct Drafting errors, unfortunately cannot be predicted. However, if you have been regularly storing your drawings as workfiles (as explained below) you will at most lose 10 to 15 minutes work.

Storing a Workfile

The workfile should be used as a security measure during drawing sessions. By periodically storing your drawing in the workfile, you have a recovery mechanism if you lose or corrupt your drawing. Loss or corruption can occur due to power failure or an error during complex command sequences. If this happens, the time lost is limited to the work done since the last `STORE 'workfile'` command.

Use the `STORE 'workfile'` command every 10-15 minutes and also before any complex modification or deletion.

Note

You are strongly advised not to leave your drawing stored only in the workfile at the end of a drawing session: always finish the session by storing the drawing in its own file. The danger of leaving the drawing only in the workfile is that any other person using Creo Elements/Direct Drafting before you return may use the `STORE 'workfile'` command and thus overwrite your drawing.

To store a drawing in the workfile:

1. Press **FILE**.
2. Pick **'workfile'** in **STORE**.

Creo Elements/Direct Drafting will overwrite the current drawing in the file called `workfile` in the current directory.

Saving a Drawing File in HPGL format

To save an entire drawing or the content of a viewport or of a box in HPGL format, select the appropriate format in the **PLOT** menu:

- HPGL file or
- HPGL2 file

Note that both of these formats are based on generic printer drivers.

Saving Selected Elements

To save a selection of elements in your drawing:

1. Enter the following command into the user input line:
`STORE`
2. Select the element(s) you want to store.
3. Specify the name of the file (in apostrophes) in which you want to store this selection.

Creating a New Creo Elements/Direct Drafting Instance

Optionally, you can run multiple instances of Creo Elements/Direct Drafting at the same time.

To create a new Creo Elements/Direct Drafting instance:

1. In the **FILE 1** menu, pick **ToNewInst**.
2. To open an empty Creo Elements/Direct Drafting instance (without any drawing file), enter an empty string (two apostrophes) into the user input line:
' '

Note

- Each instance will run in a separate window.
 - All Creo Elements/Direct Drafting instances are independent of each other; there is no master or slave instance.
 - Only a single Creo Elements/Direct Drafting license is required for any number of Creo Elements/Direct Drafting instances run by the same user on the same machine/display.
 - Newly created Creo Elements/Direct Drafting instances are initiated without the `input_customize` command. Consequently, any additional applications associated with a given Creo Elements/Direct Drafting instance are available in that instance only. For example, if you run a licensed third-party standard parts library in a Creo Elements/Direct Drafting instance, this library is not automatically available in another Creo Elements/Direct Drafting instance.
-

Opening an Existing Drawing File in a New Creo Elements/Direct Drafting Instance

To open an existing drawing file in a new Creo Elements/Direct Drafting instance:

1. In the **FILE 1** menu, pick **ToNewInst**.
2. Specify the filename (complete pathname) of the drawing file you want to load.

Viewing the Catalog

This section shows how to create a listing of the contents of any directory and see details of each file. The listing produced can either be displayed on the screen, printed on a printer connected to the system, or stored in a file. You usually look at the catalog to check names and details of files before using any file command. The following shows Creo Elements/Direct Drafting's standard catalog layout.

DIRECTORY:LARRY

File Name	Size	Descript.	Created	Modified
ASSY_15	28672	Model.MI	18-May-02	18-May-02
CYLINDER	28672	Model.MI	18-May-02	18-May-02
DRW_01	3072	Model.MI	18-May-02	18-May-02
DRW_02	21504	Model.MI	18-May-02	18-May-02
DRW_03	10240	Model.MI	18-May-02	18-May-02
DRW_04	10240	Model.MI	18-May-02	18-May-02
DRW_05	8192	Model.MI	18-May-02	18-May-02
DRW_09	28672	Model.MI	18-May-02	18-May-02
hp_catfile	13312	Sys.cat	18-May-02	18-May-02
larry_macros	8192	Model.MI	18-May-02	18-May-02

Look at a single entry of the catalog. It lists five items, referred to as catalog items (File Name, Size, Descript., Created, and Modified). Each file is actually stored with eleven catalog items, but in most catalog activities the five catalog items in the supplied catalog are sufficient. In order to fully utilize the catalog features, some knowledge of the catalog items is required. Refer to [Catalog Items on page 490](#) for further information.

The two CATALOG options are:

- Current
- Name

Cataloging the Current Directory

This is the default option.

To catalog the current directory:

1. Press **FILE**.
2. Pick **Current** in **CATALOG**.

If you wish to catalog using the LIST ALL, SELECT, SORT UP, or SORT DOWN options, refer to [Sorting the Catalog on page 489](#).

3. Pick the desired destination for the catalog:
 - To send the catalog to the screen or a printer, pick **Screen** or **Printer** in **OPTIONS**.

- To send the catalog to a file, pick **Delete Old** or **Append** from **OPTIONS** to overwrite or append the file. Enter the name of the file. The catalog will now be sent to the file.

Cataloging a Named Directory

To catalog any directory:

1. Press **FILE**.
2. Pick **Name** in **CATALOG**.
3. Enter the directory name (for example `' /users/larry'`). For information concerning directory paths, refer to [File Organization and Names on page 463](#).

If you wish to catalog using the **LIST ALL**, **SELECT**, **SORT UP**, or **SORT DOWN** options, refer to [Sorting the Catalog on page 489](#).

4. Pick the required destination for the catalog:
 - To send the catalog to the screen or printer pick **Screen** or **Printer** in **OPTIONS**.
 - To send the catalog to a file pick **Delete Old** or **Append** in **OPTIONS** to overwrite or append the file. Enter the name of the file.

The catalog will now be sent to the file.

Listing Catalog Items

This section shows how to produce a special catalog layout. This lists all catalog items and is useful during external file handling operations.

The following shows a typical catalog listing.

```
DIRECTORY:LARRY
FILE_NAME: ASSY_15
PHYS_NAME: ASSY_15
FILE_DESC: Model.MI
FILE-TYPE: Data
FILE_SIZE: 28672
CREATE_DATE: 18-Apr-02  4:52:00
MODIFY_DATE: 18-May-02  5:49:03
ACCESS_DATE: 18-May-02  5:49:03
NUM_ACCESS: 3
PROG_NAME: Designer Drafting
PROG_REV: 06.00
```

```
=====
FILE_NAME: CYLINDER
PHYS_NAME: CYLINDER
FILE_DESC: Model.MI
FILE_TYPE: Data
```

FILE_SIZE: 28672
CREATE_DATE: 17-Apr-02 4:55:04
MODIFY_DATE: 19-May-02 4:55:08
ACCESS_DATE: 19-May-02 4:55:08
NUM_ACCESS: 4
PROG_NAME: Designer Drafting
PROG_REV: 06.00
=====

To list catalog items:

1. Press **FILE**.
2. Pick **Current** in **CATALOG**.
3. Pick **LIST ALL**.

You can use **SELECT**, **SORT UP**, or **SORT DOWN** to produce a selective list.

4. Pick the required destination in **OPTIONS**.

The catalog produced will be of a revised layout and contain all the catalog items.

Selecting Catalog Entries

You may want to produce a selective catalog.

For example, you could catalog only filenames beginning with **J** or all files created later than April 1999. You can **SELECT** on any catalog item, and up to 10 Select options can be used in a **CATALOG** command.

To select catalog items:

1. Press **FILE**.
2. Pick the required **CATALOG** option.
3. Pick **SELECT**.
4. Pick the item you wish to select in **SORT UP** or **SORT DOWN**.
5. Enter the required criterion. Refer to [Entering Criteria for a Selection on page 486](#).

With the criterion entered, you can repeat the **SELECT** process again as necessary.

6. Pick the required destination for the catalog in **OPTIONS**.

Entering Criteria for a Selection

To enter selection criteria:

1. Enter a relational operator. For example:

<=

Table 11. Relational Operators on page 487 gives the relational operators.

Table 11. Relational Operators

Character	Meaning
=	equal (this is the default operator)
<>	not equal
>	greater than
<	less than
>=	greater than or equal to
<=	less than or equal to

2. Enter the criterion text. This could be an item such as 15-Apr-1999 or you could use wildcards. Wildcards help you perform even more exclusive selections.

Table 12. Explanation of Wildcards on page 487 explains the use of wildcards.

Table 12. Explanation of Wildcards

Wildcard	Examples	Meaning
*		Matches any string
	K*	matches all strings beginning with K
	*1	matches all strings ending with 1
	abc	matches any string containing abc
	*	matches any string Matches any character
?		
	K?	K? matches all 2 character strings beginning with K
	?K	?K matches all 2 character strings ending with K
	?abc?	?abc? matches all 5 character strings with abc as second, third and fourth characters.
[...]		Matches any one of the enclosed characters.
	K[abc]	matches all 2 character strings beginning with K, and with an a,b or c as the second character.

Table 12. Explanation of Wildcards (continued)

Wildcard	Examples	Meaning
	KL[d-h]	matches all 3 character strings beginning with KL and ending with d, e, f, g or h.
	DRW[0-9][0-9]	matches any 5 character string beginning with DRW and ending with a two digit number.

Table 13. Explanation of Wildcards (continued)

Wildcard	Examples	Meaning
[! . . .]		Performs a boolean NOT operation on the characters inside the brackets.
	K[!abc]	matches any 2 character string beginning with K but without a, b or c as the second character.
	K[!a-c]??	matches any 4 character string beginning with K, second character may not be a, b or c'.
	DRW[!6-9][0-9]	matches any 5 character string beginning with DRW, ending with 0 to 9, with the fourth character not equal to 6 to 9.
\		Removes any special meaning from the following character.
	\?*	matches any string beginning with the character ?.

How to Use Selection

Suppose you require a catalog of the directory 'larry' from directory '/users', and only those files beginning with D are to be listed. The catalog is to be displayed to the screen.

To produce the catalog:

1. Press **FILE**.
2. Pick **Name** in **CATALOG**.
3. Enter '/users/larry'
4. Pick **SELECT**, then 'FILE_NAM' in **SORT DOWN**.
5. Enter "D*"
6. Pick Screen in **OPTIONS**.

The following shows the catalog listing.

DIRECTORY:LARRY

File Name	Size	Descript.	Created	Modified
DRW_01	3072	Model.MI	18-May-99	18-May-99
DRW_02	21504	Model.MI	18-May-99	18-May-99
DRW_03	10240	Model.MI	18-May-99	18-May-99
DRW_04	10240	Model.MI	18-May-99	18-May-99
DRW_05	8192	Model.MI	18-May-99	18-May-99
DRW_09	28672	Model.MI	18-May-99	18-May-99

Sorting the Catalog

This section shows how to produce sorted catalogs.

Both commands are used in the same way, only the order of the sort is different. For example, you would use SORT UP to produce a catalog such that all entries are sorted on file size with the smallest appearing first.

For a high to low sort you would use the SORT DOWN option.

To sort a catalog:

1. Press **FILE**.
2. First select the required CATALOG.
3. Pick either **SORT UP** or **SORT DOWN**.
4. Pick the items you wish to sort on in SORT UP or SORT DOWN.

You can also pick SELECT, LIST ALL, or both.

5. Pick the required destination in OPTIONS.

The catalog produced will be sorted on the selected items with the selected order, either low to high or high to low.

Sorting a Catalog – Example

Suppose you require a catalog of the directory 'larry' in directory '/users'. The catalog should be sorted low to high on file size. The catalog is to be written to the file '/users/cat_cont', overwriting the existing file.

To produce the catalog and write it to an existing file:

1. Press **FILE**.
2. Pick **Name** in CATALOG.
3. Enter '/users/larry'
4. Pick **SORT UP**.

5. Pick **'FILE_SIZ'** in **SORT UP**.
6. Pick **Delete Old** in **OPTIONS**.
7. Enter **'/users/cat_cont'**

The following shows **'/users/cat_cont'**.

DIRECTORY:LARRY

File Name	Size	Descript.	Created	Modified
DRW_01	3072	Model.MI	18-May-99	18-May-99
DRW_05	8192	Model.MI	18-May-99	18-May-99
larry_macros	8192	Model.MI	18-May-99	18-May-99
DRW_03	10240	Model.MI	18-May-99	18-May-99
DRW_04	10240	Model.MI	18-May-99	18-May-99
hp_catfile	13312	Sys.cat	18-May-99	18-May-99
DRW_02	21504	Model.MI	18-May-99	18-May-99
ASSY_15	28672	Model.MI	18-May-99	18-May-99
CYLINDER	28672	Model.MI	18-May-99	18-May-99
DRW_09	28672	Model.MI	18-May-99	18-May-99

Catalog Items

The nine sorting options in **SORT UP/SORT DOWN** are used to produce specially sorted catalogs.

When entering an Item Value that consists of letters, or a combination of letters and digits, it is necessary to use quotation marks. However, for Item Values consisting of digits only, it is not. [Table 14. Description of Catalog Items on page 490](#) gives details of how to use the catalog items and of the format for inputting the item values.

Table 14. Description of Catalog Items

Item Name	Example of Item Value	Comments
Filename	"Drw_101"	This is the name you use to store the file. Length is normally limited to 60 characters; however, some systems support longer names.
Physical Name	"Drw_101a"	In most cases the same as the filename. However, if the filename contains characters not allowed by the operating system (for example :), or if the filenames are longer than 14 characters, the application automatically generates a unique

Table 14. Description of Catalog Items (continued)

Item Name	Example of Item Value	Comments
		physical name. The physical name is used for external file handling.
File Size	3987	An integer value giving the size of the file in bytes.
File Type	"Data"	All drawings are classified as "Data". Other file types include "Code" and "Text" for text files.
File Description	"Model.MI"	Describes the type of file. Examples are "Catalog" for catalog files and "Comp.MI" for compressed MI format.
Create Date	"17-Apr-99"	The date the file was created. This is not affected by overwriting or copying.
Modify Date	"19-Apr-99"	The date the file was last modified. Date is changed by any append or overwrite command.
Access Date	"19-Apr-99"	The last date the file was loaded.
Number of Accesses.	3	Number of times the file has been accessed by any file command, except CATALOG
Program Name.	"Designer Drafting"	Not normally used
Program Revision	08.00	Not normally used.

Selecting the Current Directory

To select the directory in which you want to work:

1. Press **FILE**.
2. Pick **CURR DIR** (or use the FILE BROWSER window).
3. Enter the required directory path and directory name.

Creo Elements/Direct Drafting will now set the directory specified as the current one.

Copying Files and Directories

This section shows how to copy files and directories. Remember that filenames, directories, and subdirectories can be selected from the FILE BROWSER window or entered on the command line.

Copying Files

To copy a file:

1. Press **FILE**.
2. Pick **COPY**.
3. Enter the filename. The following four wildcards can be used in conjunction with the specified source name:
*, [...], ?, \
4. Select from the following options:
 - Enter **SELECT** and choose from the files already specified using the catalog sorting mechanism. You can also select one of the following relational operators: =, <>, >, <, >=, and <=.
 - Pick **Delete Old** or enter **SCREEN**, or both.
5. Enter 'destination_name'

Copying a File Using the Selection Mechanism

The following example shows how to:

- Find files in the current directory (**users**) with a filename beginning with **f**.
- Select files greater than 250 bytes in size.
- Copy those files to directory **mary**.

[Figure 260. File Structure Before Copy Command on page 493](#) shows the file structure before the copy command.

Figure 260. File Structure Before Copy Command

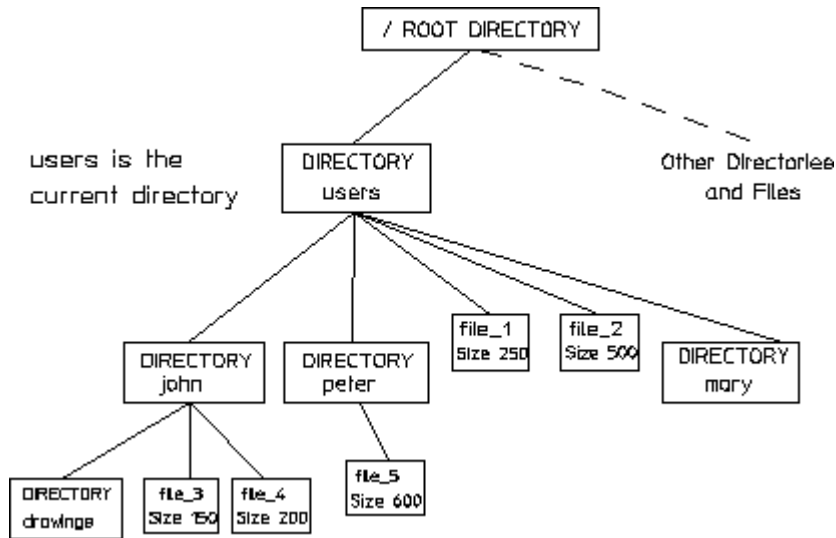

1. Press **FILE**.
2. Pick **COPY**.
3. Enter 'f*'

Creo Elements/Direct Drafting finds file_1 and file_2.

4. Pick SELECT in **FILE**.
5. Pick the catalog item 'FILE_SIZ' in SORT UP.
6. Enter '>250'

Creo Elements/Direct Drafting now searches for files that are larger than 250 bytes and finds file_2.

7. Enter 'mary'

Creo Elements/Direct Drafting will now copy file_2 to the directory mary.

Figure 261. File Structure After Copy Command on page 494 shows the file structure after the copy command.

Figure 261. File Structure After Copy Command

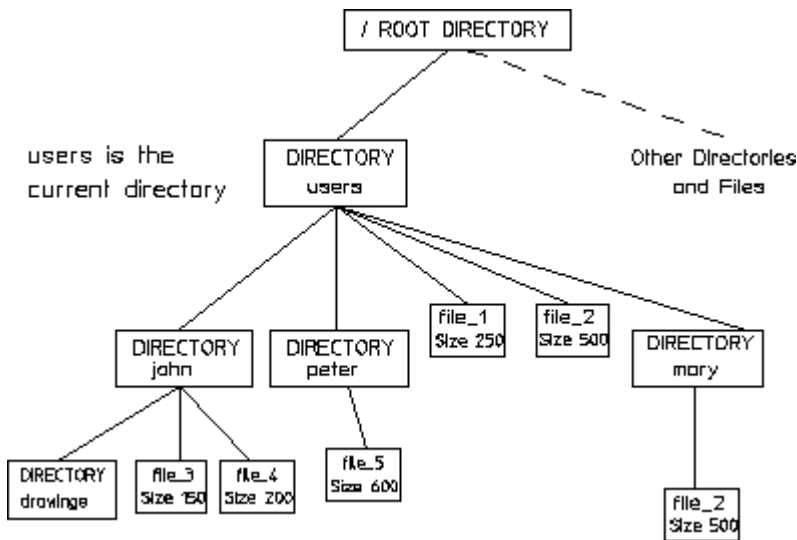

Copying Directories

You must use `RECURSIVE` to copy directories.

To copy directories you must specify the name of the directory as the source name (include a directory path if required). The entire directory with its files and subdirectories will then be copied to the directory specified as the destination file.

Note

- `RECURSIVE` is the only option that allows you to copy directories.
 - `RECURSIVE` must be typed in.
-

Copying a Directory Using Recursive

The following example shows how to copy the directory `/users/peter` to the directory `/john/drawings`.

[Figure 262. Directory Structure Before Copy Command on page 495](#) shows the directory structure before the copy command.

Figure 262. Directory Structure Before Copy Command

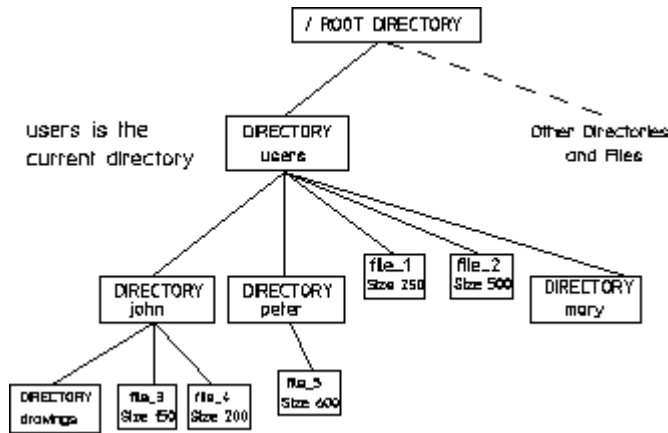

1. Press **FILE**.
2. Pick **COPY**.
3. Enter `'/users/peter'`
Creo Elements/Direct Drafting finds the directory `peter`.
4. Enter `RECURSIVE`
5. Enter `'/john/drawings'`
Creo Elements/Direct Drafting will now copy the directory `peter` to the directory `drawings`.

Figure 263. Directory Structure After Copy Command on page 495 shows the directory structure after the copy command.

Figure 263. Directory Structure After Copy Command

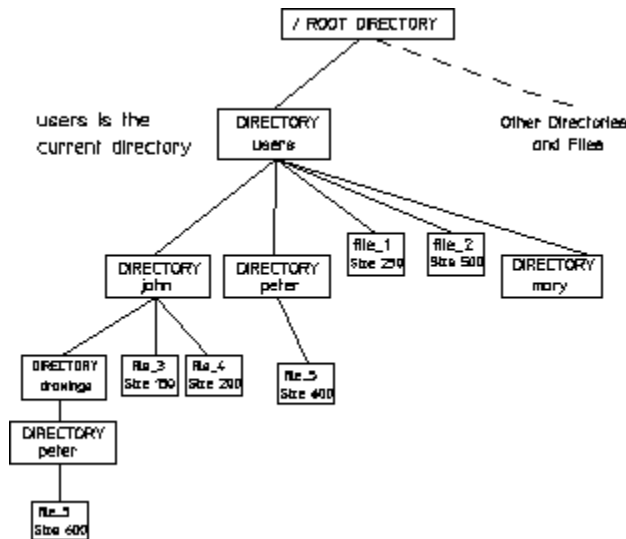

Copying Options

When you are copying files or directories, before entering your destination filename or directory name, you can pick one of the following two options.

- **Delete Old** — If you wish to overwrite an existing file, select **Delete Old** in **OPTIONS**.
- **Screen** — This option allows you to view the files and directories to be copied, on the built-in editor. If you leave the editor positively by pressing **[Ctrl] [D]**, the copy command will still be active and you will be prompted to specify a destination name. If however, you leave the editor negatively by pressing **[Esc] [Break]**, the copy command will be canceled, and your files and directories will not be copied.

Note

- If you have specified more than one file as the source name, you must specify a directory as the destination name, otherwise an error message will be displayed and the command will not operate.
 - It is not possible to specify more than one file or directory as the destination name.
 - It is not possible to copy device files, block special files, or char special files.
-

Purging Files or Directories

This section shows how to purge a file or directory.

To purge a file or directory:

1. Press **FILE**.
2. Pick **PURGE**.
3. Enter the name of the files or directories to be purged using a directory path if required.

The following four wildcards can be used in conjunction with the specified files or directories:

*****, **[...]**, **?**, and ****.

4. Choose one of the following options:
 - Pick **Screen** to display the files and/or directories for deletion.
 - Pick **SELECT** in **FILE** to use the catalog selection mechanism on the files or directories you have already specified.

- Press **CONFIRM** to complete the command.

Purging Examples

For the purpose of the following examples, assume the current directory is /users.

Figure 264. File Structure Before Purging on page 497 shows the file structure before purging.

Figure 264. File Structure Before Purging

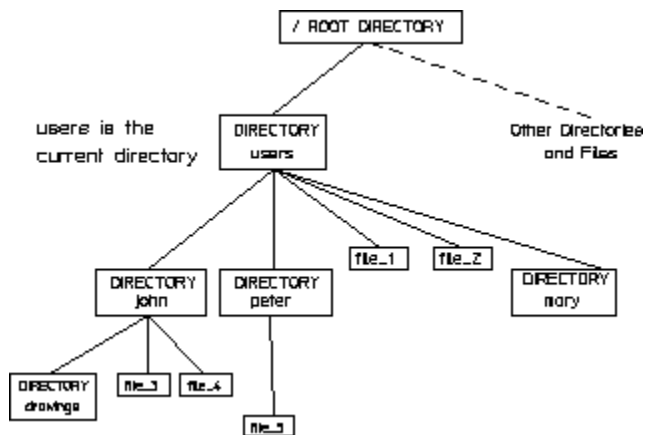

Example 1

To purge file_1 and file_2:

1. Press **FILE**.
2. Pick **PURGE** in **FILE**.
3. Enter ' * '

Creo Elements/Direct Drafting finds the directories john and peter, the files file_1 and file_2, and finally the directory mary.

4. Pick **SELECT** and the catalog item 'FILE_TYP'.
5. Enter <> 'DIR'

Creo Elements/Direct Drafting sorts through these three directories and two files and finds the files file_1 and file_2.

6. Press **CONFIRM**.

The files file_1 and file_2 are purged.

Figure 265. File Structure After Purging on page 498 shows the file structure after purging.

Figure 265. File Structure After Purging

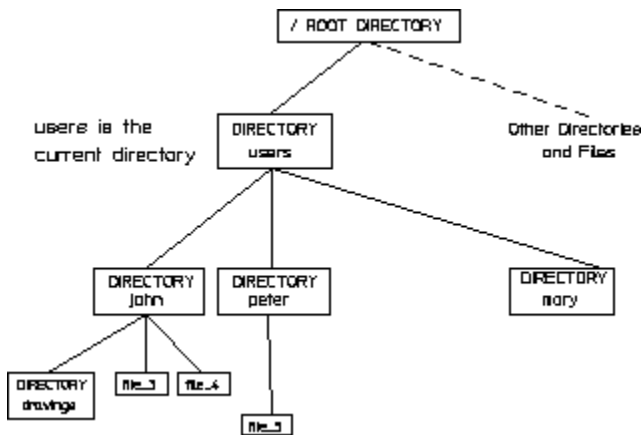

Example 2

Figure 266. Directory Structure Before Purging on page 498 shows the directory structure before purging.

Figure 266. Directory Structure Before Purging

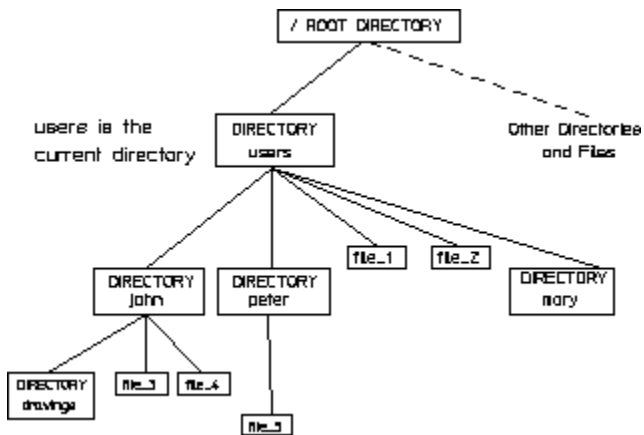

To purge directories john, peter and mary:

1. Press **FILE**.
2. Pick PURGE in **FILE**.
3. Enter ' * '

Creo Elements/Direct Drafting finds the directories john and peter, the files file_1 and file_2, and finally the directory mary.

4. Pick **SELECT** and the catalog item 'FILE_TYP'.
5. Enter 'DIR'

Creo Elements/Direct Drafting now sorts through these three directories and two files and finds the directories `john`, `peter` and `mary`.

6. Press **CONFIRM**.

In the last case (example 2) nothing will be purged. Creo Elements/Direct Drafting will try to purge the directory `john`. However, since this directory is not empty, an error message will be given and the operation will be terminated. If however, the empty directory `mary` had been the first directory to be found by Creo Elements/Direct Drafting, it would have been purged and Creo Elements/Direct Drafting would then have given an error message, since it would have then found either the directory `john` or `peter`, neither of which are empty.

To successfully delete `john`, `peter` and `mary`, you must use the `RECURSIVE` option.

Using `RECURSIVE` you can purge files, non-empty directories and empty directories. `RECURSIVE` operates on the whole directory path tree of the directory you have already specified.

 **Note**

- `RECURSIVE` is the only option that allows you to copy directories.
 - `RECURSIVE` must be typed in.
-

Example 3

The following example shows how to delete the directory `john` using the `RECURSIVE` option. [Figure 267. Directory Structure Before Purging on page 499](#) shows the directory `john` before purging.

Figure 267. Directory Structure Before Purging

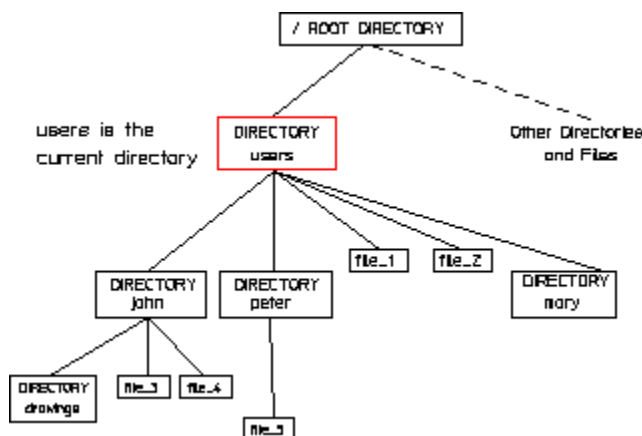

1. Press **FILE**.

2. Pick Purge in **FILE**.
3. Enter 'john'

Creo Elements/Direct Drafting will find the directory john.

4. Enter RECURSIVE

If you wish to view the files and directories you intend to purge on the built-in editor, pick Screen before pressing **CONFIRM**. If you leave the editor positively, [Ctrl] [D], the purge function will be performed. If however, you leave the editor negatively, by pressing [Esc] [Break], the purge command will be canceled, and your files and directories will remain.

5. Press **CONFIRM**.

The directory john, with its files, will now be purged.

Figure 268. Directory Structure After Purging on page 500 shows the directory structure after purging.

Figure 268. Directory Structure After Purging

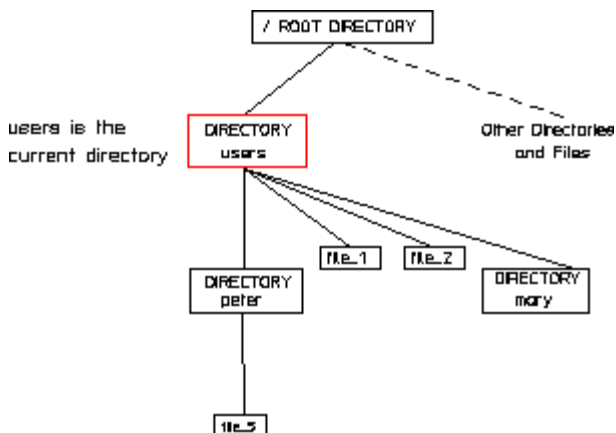

Creating Directories

To create a new directory:

1. Enter CREATE_DIRECTORY
2. Enter a name for the new directory.

Editing Files

This section shows how to edit the contents of a file using the text editor.

1. Press **FILE**.
2. Pick **EDIT FILE** in **FILE**.

-
3. Enter the directory path and name of the file to be edited.

The normal screen will now change and display the contents of the file.

4. Use the keyboard and edit keys to alter the file as required.
5. When you have finished editing the file, press [Ctrl] [D].

Creo Elements/Direct Drafting will restore the file and return you to the normal screen.

For details of macro writing and using the text editor, refer to the manual Writing Macros with Creo Elements/Direct Drafting.

Inputting Files

This section shows how to input the contents of a file into your system's main memory. The command is mainly used to input macros and text fonts:

1. Press **FILE**.
2. Pick **INPUT**.
3. Enter the name of the file to be input.

Creo Elements/Direct Drafting will now input the desired file into memory.

Saving Files

If for some reason you are unable to save your drawing in the normal way, you should save it using **SAVE**. This command translates all the drawing data into input commands and stores them in a file. Note that only the drawing geometry is saved; hatching and dimensions are lost:

1. Press **FILE**.
2. Pick **SAVE**.
3. Enter a name for the file.

Creo Elements/Direct Drafting saves the drawing geometry in a file.

If you want to recall the drawing geometry:

1. Press **FILE**.
2. Pick **INPUT**.
3. Enter "filename"

Creo Elements/Direct Drafting recalls the drawing geometry.

16

Revision Checking

Using Revision Checking 504

This chapter tells you how to use the commands and options that allow you to compare similar drawings. This facility is particularly useful in design offices where successive drawings are revised and you need to identify the differences between revisions. For example, suppose you create a drawing of a plate early on in the development stage. A few weeks later you revise this drawing by stretching it, adding fillets, and adding holes. You can now compare the original drawing with the revised drawing to see where changes have been made. The differences between the original and revised drawings are shown in color.

 **Note**

Revision checking is possible on drawings stored in MI-format 2.10 or higher. Incorrect results may occur if you attempt to compare drawings saved in MI-formats earlier than 2.10.

Figure 269. Original Drawing and Revised Drawing on page 503 shows the original drawing (A) and the revised drawing (B). Figure 270. Both Files Loaded on page 503 shows A and B superimposed so that you can easily identify the modified elements.

Figure 269. Original Drawing and Revised Drawing

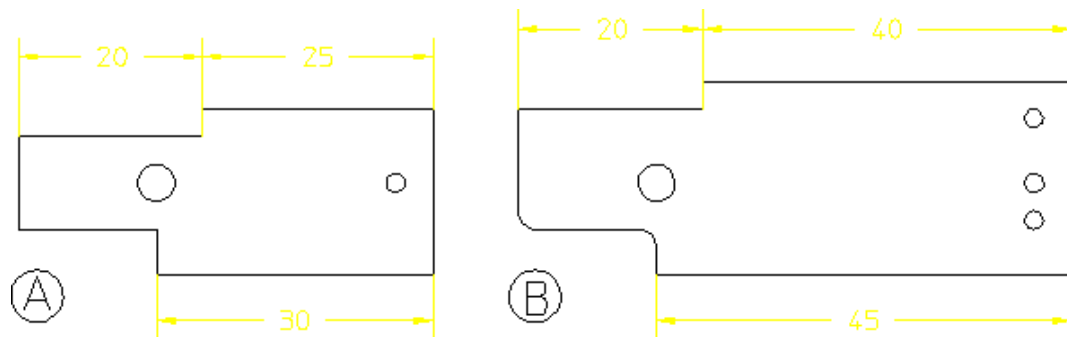
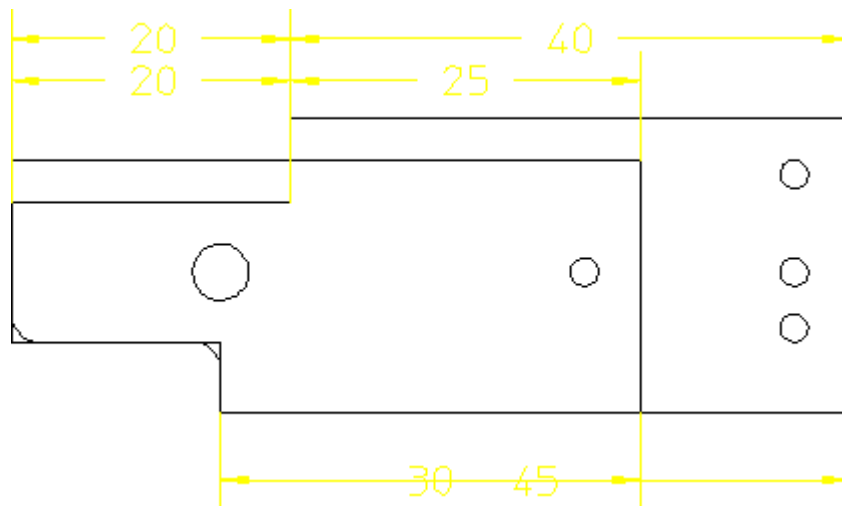

Figure 270. Both Files Loaded



Using Revision Checking

To use the revision checking facility, pick REVCHK in **FILE**. The menu appears on the screen; it contains the following commands:

- LOAD FILES
- COMPARE
- VIEW
- RESET SHOW
- SHOW DIFF
- CONTINUE
- SET COLOR

Before you begin, you must have two drawings available, for example:

dt_cs_rev06 The original drawing

dt_cs_rev10 The revised drawing

1. Pick REVCHK in **FILE**
2. Pick LOAD FILES
3. Enter `dt_cs_rev06'
4. Enter `dt_cs_rev10'

Creo Elements/Direct Drafting displays the two drawings overlapping.

5. Pick Geometry in COMPARE

Creo Elements/Direct Drafting compares the location of the geometry and texts (without comparing the parts structure) in the two drawings and shows the result of the comparison in different colors according to the following defaults:

Blue	Identical geometry elements in both drawings
Green	Differences in the original drawing
Red	Differences in the modified drawing

The other options in the COMPARE menu do the following:

+ Annotat	In addition to Geometry, this option also compares the properties of the geometry and texts—linetype, color, text attributes, info texts—and the dimensions and hatches in both drawings.
+ Parts	In addition to + Annotat, this option compares the parts structure in both drawings. If you modify a drawing solely by a scaling factor, picking Parts displays all elements in red (indicating a difference). However, the options + Geometry and + Annotat displays elements and annotation in blue (indicating identical elements).

 **Note**

Both drawings must have the same location compared to the drawing origin to get meaningful results from the comparison.

Be careful when working with scaling factors (PART SCALE).

Viewing Single Drawings

When both drawings are loaded, you can toggle between them using the VIEW command. To display the original drawing only, pick Drw 1 in VIEW. To display the revised drawing only, pick Drw 2 in VIEW. To display both drawings, pick Both in VIEW.

Continuing with the Drawing

When you are ready to continue with your drawing, pick With Drw 1 or With Drw 2 in the CONTINUE command. Creo Elements/Direct Drafting displays the selected drawing and deletes the other drawing. You can now continue working on this drawing in the usual manner.

Unlike the VIEW command, the CONTINUE command does not let you toggle between the two drawings as it deletes the one you do not select.

Resetting Colors and Showing Differences

The colors generated after picking an option in the COMPARE menu can be reset to their original colors.

RESET SHOW	Use this command to show the drawings in their original colors.
SHOW DIFF	Use this command to show the drawing elements in different colors, corresponding to the result of the last comparison.

Changing the Color Scheme

To change the color scheme:

1. Pick **Diff** in 1 in **SET COLOR**
2. Enter the new color (the default is green)
3. Pick **Identical** in **SET COLOR**
4. Enter the new color (the default is blue)
5. Pick **Diff** in 2 in **SET COLOR**
6. Enter the new color (the default is red)

The color changes take effect with the next redraw.

17

Annotation

Introduction.....	508
Loading an Annotation Drawing.....	511
Using the Sheet Browser to Navigate among Sheets and Views.....	511
Views	512
Showing Differences in a View Following a 3D Change	513
Handling Annotation Elements	514
Dimensions.....	514
Sheets.....	515
Hiding, Deleting, Unhiding.....	516
Unhiding Elements	516
Changing Colors, Linetypes and Hatches.....	517
Showing and Storing	517
Storing the Drawing for Further Use in Annotation.....	518

This chapter discusses the Creo Elements/Direct Annotation module.

Introduction

The Creo Elements/Direct Annotation module included in Creo Elements/Direct Drafting enables you to visualize, annotate and edit MI format 2D drawings generated by Creo Elements/Direct Annotation.

General Procedure

The general Creo Elements/Direct Annotation procedure comprises the following steps:

- Prepare the drawing environment Creo Elements/Direct Annotation.
- Load an MI file generated in Creo Elements/Direct Annotation.
- View, annotate and edit this file as appropriate. For example, you can manipulate views and you can hide or delete elements. Also, you can modify and/or add geometry by means of regular Creo Elements/Direct Drafting commands. Note that a warning message is displayed for any "structurally dangerous" operations that would impair 3D/2D associativity.
- Following changes to the underlying 3D model in Creo Elements/Direct Drafting, update the relevant view(s) to visualize and review the resulting changes in 2D.
- Edit the 2D views as appropriate.
- Check the part structure of the Annotation MI file by means of the Creo Elements/Direct Drafting Part Browser.
- Save the 2D drawing for further use in Creo Elements/Direct Drafting or in Creo Elements/Direct Annotation.

Annotation Rules

To ensure that the Annotation MI drawing file retains its 3D/2D associativity for further use in Creo Elements/Direct Annotation, you must observe the following rules when using the Creo Elements/Direct Drafting **Annotation** module:

- Do not copy one drawing into another drawing.
- Do not manually insert one or more sheets into another drawing.
- Do not manually insert views into a sheet (using the view definition commands of Creo Elements/Direct Annotation). Only use the **Sheet** commands provided by the Creo Elements/Direct Drafting **Annotation** module.
- Do not change or delete info texts beginning with "SD_" or "DOCU" or "AM_".

-
- Do not modify view parts or 3D parts below view parts with the commands in the **Modify** menu of Creo Elements/Direct Drafting. Only use the **View** commands provided by the Creo Elements/Direct Drafting **Annotation** module.
 - Do not scale view parts or 3D parts below view parts with the command in the **Parts** menu of Creo Elements/Direct Drafting. Only use the **Scale** command provided by the Creo Elements/Direct Drafting **Annotation** module.
 - Do not change the scale of the TOP part or the parts below the TOP part with the Creo Elements/Direct Drafting **Parts/Drawing Scale** commands.
 - Do not change the owner of a part or subassembly (which belong to the drawing) in Creo Elements/Direct Drafting.
 - Do not use Creo Elements/Direct Drafting to smash or gather any part created by Creo Elements/Direct Annotation (sheets, frames, view parts, parts below view parts, sketches).
 - Do not create detail parts in Creo Elements/Direct Drafting — these would not be associative to the 3D model. Use the **Detail** command in Creo Elements/Direct Annotation to create detail views.

Preservation of Modifications

The following modifications in the Creo Elements/Direct Drafting **Annotation** module are preserved when an update is performed in Creo Elements/Direct Annotation:

- Attribute changes such as line type or line color, info text added to geometry elements derived from the 3D model.
- Centerlines created in Creo Elements/Direct Drafting.
- Dimensions, texts, symbols and additional 2D geometry created in the appropriate view parts. (Note that symbols, text and additional 2D geometry can be added to each part except the TOP part).
- Geometry belonging to subparts which are not owned by the TOP part named "SD_drawing".
- Hatches added in Creo Elements/Direct Drafting.

Limitations

Some operations performed in the Creo Elements/Direct Drafting **Annotation** module will not deliver the expected results after reloading and updating in Creo Elements/Direct Annotation.

- Parts created in Creo Elements/Direct Drafting as sub-parts of the TOP part named "SD_drawing" will not be loaded into Creo Elements/Direct Annotation.

-
- Geometry or any other additional elements created in the TOP part named "SD_drawing" will not be loaded into Creo Elements/Direct Annotation.
 - Subparts created in Creo Elements/Direct Drafting (and which are not owned by the TOP part) will not be displayed in the Drawing Browser of Creo Elements/Direct Annotation. However, their geometry is displayed in the viewport.
 - Leader lines (or text with leaderlines) created in Creo Elements/Direct Drafting will not behave associatively in Creo Elements/Direct Annotation.
 - Hatch holes automatically created in Creo Elements/Direct Drafting (forced by dimensions or texts when Creo Elements/Direct Drafting option TEXT_HOLE_INSERTION is set to ON by default) do not update associatively in Creo Elements/Direct Annotation.
 - Hatch holes automatically created in Creo Elements/Direct Annotation for text do not update associatively in Creo Elements/Direct Drafting when the text is changed in Creo Elements/Direct Drafting.
 - Hatches that were automatically created in Creo Elements/Direct Annotation but deleted in Creo Elements/Direct Drafting will re-appear after the next update in Creo Elements/Direct Annotation.
 - 2D view parts created in Creo Elements/Direct Annotation that are renamed in Creo Elements/Direct Drafting get their original name during the next update in Creo Elements/Direct Annotation.
 - If you split or merge 2D geometry in Creo Elements/Direct Drafting which was derived from the 3D geometry during an update in Creo Elements/Direct Annotation, the geometry will look like the original one after the next update in Creo Elements/Direct Annotation.

Preparing the Creo Elements/Direct Drafting Drawing Environment

Before you load an MI file generated in Creo Elements/Direct Annotation, be sure to complete the following steps:

1. To make sure that the top part is empty, enter the following into the user input line:
RESET_SYSTEM
CONFIRM
2. Creo Elements/Direct Annotation does not update the preview data in the Annotation MI file loaded in Creo Elements/Direct Drafting. Therefore, switch off the Creo Elements/Direct Drafting **Preview** mode by entering the following in the Creo Elements/Direct Drafting user input line:
PRE_VIEW

OFF

3. Activate the Creo Elements/Direct Drafting **Annotation** module by clicking **MODULES, ANNOTATION**.

 **Note**

To toggle between the ANNOTATION screen menu levels, simply click DRAWING or VIEW or UNHIDE at the bottom of the ANNOTATION menu.

Loading an Annotation Drawing

When you have prepared the Creo Elements/Direct Drafting drawing environment as discussed in [Preparing the Creo Elements/Direct Drafting Drawing Environment on page 510](#), proceed as follows to load an MI file generated in Creo Elements/Direct Annotation.

1. In **ANNOTATION**, click **DRAWING, FBROWSER**.
2. Select the MI file you want to load from the file browser.

Using the Sheet Browser to Navigate among Sheets and Views

The Sheet Browser enables you to quickly and easily select a sheet or a view included in a sheet.

Displaying the Sheet Browser

To display the Sheet Browser:

1. In **ANNOTATION**, click **DRAWING, SHEETBROWS**.
2. Drag the Sheet Browser to where you want to display it.

Selecting a Sheet or View from the Sheet Browser

To select a sheet from the Sheet Browser:

1. In the Sheet Browser, click **Curr Sheet**.
2. Click on the associated sheet number in the Sheet Browser.

To select a view from the Sheet Browser:

1. In the Sheet Browser, select the sheet in which this view is included.

2. Click **Curr View**.
3. Click on the associated view number in the Sheet Browser.

Views

The Creo Elements/Direct Drafting **Annotation** module provides a number of commands for selecting, changing and manipulating views.

Selecting the Current View

In addition to the method described in [Selecting a Sheet or View from the Sheet Browser on page 511](#), you can proceed as follows to select the current view in the current sheet:

1. In **ANNOTATION**, click **DRAWING, CUR VIEW**.
2. Click on the view you want to make current.

Modifying Views

You can change the position of views on a sheet. Also, you can move views between sheets. Note that a warning message is displayed for any "structurally dangerous" operations that would impair 3D/2D associativity.

To change the position of one or multiple views:

1. In **ANNOTATION**, select the option for the view change you want to perform:

2 Pts in MOVE VIEW	Moves the selected view(s) from the first point to the second point.
Horiz in MOVE VIEW	Moves the selected view(s) by the specified horizontal distance.
Vert in MOVE VIEW	Moves the selected view(s) by the specified vertical distance.
Sht 2 Sht in MOVE VIEW	Moves the selected view(s) to another sheet.
ROT VIEW	Rotates the selected view(s) by the specified angle about the specified center.
SCALE VIEW	Scales the selected view(s).

2. Select the view(s) to which you want to apply this change.

Hiding Hidden Lines

To hide hidden lines in the Annotation MI file:

-
1. In **ANNOTATION**, click **HIDE** below **HID LINE**.
 2. Select the view(s) in which you want to hide hidden lines.

Hiding Tangent Lines

To hide tangent lines in the Annotation MI file:

1. In **ANNOTATION**, click **HIDE** below **TAN LINE**.
2. Select the view(s) in which you want to hide tangent lines.

Showing Hidden Lines

To show (previously hidden) hidden lines in the Annotation MI file:

1. In **ANNOTATION**, click **SHOW** below **HID LINE**.
2. Select the view(s) in which you want to show hidden lines.

Showing Tangent Lines

To show (previously hidden) tangent lines in the Annotation MI file:

1. In **ANNOTATION**, click **SHOW** below **TAN LINE**.
2. Select the view(s) in which you want to show tangent lines.

Showing Differences in a View Following a 3D Change

Any view you see in the Creo Elements/Direct Drafting **Annotation** module is a 2D derivative of a 3D model view in Creo Elements/Direct Modeling. When the underlying 3D model changes in Creo Elements/Direct Modeling, you can update the associated view in Creo Elements/Direct Drafting **Annotation** and check for differences in the view before and after this update.

Showing Differences

To show differences:

1. In **ANNOTATION**, click **VIEW** (unless the **VIEW** options are already displayed).
2. In **ANNOTATION**, click **SHOW DIFF**.
 - By default, the Creo Elements/Direct Annotation update colors are used to mark differences as well as unchanged elements.
 - Any unchanged elements are marked by the equal info text flag.

-
- Any changed elements are marked by the non-equal info text flag.

Hiding Differences

To hide the differences in a view before and after the update of the underlying 3D model, click **RESET SHOW**. Note that **RESET SHOW** returns the view to the state prior to **SHOW DIFF**.

Handling Annotation Elements

Optionally, you can change or accept annotation elements.

Changing an Annotation

You can change an annotation, e.g. by selecting a different reference element.

To change an annotation:

1. In **ANNOTATION**, click **CHANGE**.
2. Click on the annotation you want to change.
3. Follow the prompts displayed in the prompt line.

Accepting All Annotation Elements

To accept all (current or changed) annotation elements, click **ACCEPT** in **ANNOTATION**.

Dimensions

Moving a Dimension

To move a dimension:

1. In **ANNOTATION**, click **MOVE DIM**.
2. Click on the dimension you want to change.
3. Drag the dimension text to its new position.

Returning a Moved Dimension to Its Original Position

To move a dimension back to its original position:

1. In **ANNOTATION**, click **RESET DIM**.

2. Click on the dimension you want to restore.

Sheets

You can create, select, change, and modify sheets.

Creating a Sheet

To create a new sheet:

1. In **ANNOTATION**, click **CREA SHEET**.
2. Enter a number for the new sheet. Check the Sheet Browser for existing sheet numbers.
3. In the file browser, select a frame for the new sheet.

You can now add new views to this sheet, e.g. by moving from an existing sheet or by loading a view from Creo Elements/Direct Drafting.

Selecting the Current Sheet

To make a sheet current:

1. In **ANNOTATION**, click **CUR SHEET**.
2. Click on the sheet you want to make current.

Alternatively, select the current sheet from the Sheet Browser (see [Selecting a Sheet or View from the Sheet Browser on page 511](#)).

Modifying a Sheet

You can change the position of the frame of a sheet. Also, you can replace the current frame of a sheet by a different sheet, or you can delete a sheet. Note that a warning message is displayed for any "structurally dangerous" operations that would impair 3D/2D associativity.

To modify a sheet:

1. In **ANNOTATION**, select the **MOD SHEET** option you want to perform:

Frame Type	to select a different frame from the Load Frame browser, thus replacing the existing frame by the newly selected one.
Frame Pos	to move the frame to the desired position.
Del Sheet	to delete the sheet.
Renumber	to change the sheet number.

2. Select the sheet to which you want to apply this change.

Hiding, Deleting, Unhiding

The Creo Elements/Direct **Annotation** module provides a number of commands for selectively hiding, deleting or unhiding elements in the drawing.

Hiding or Deleting Elements

Any elements you hide are simply "invisible" in the drawing. Any elements you delete are physically removed from the drawing. Note that a warning message is displayed for any "structurally dangerous" operations that would impair 3D/2D associativity.

To hide or delete elements:

1. In **ANNOTATION**, select the option for the **HIDE** operation you want to perform:

No in DEL OPTN	Hides element but does not delete them. Elements hidden in this way can be restored through an UNHIDE operation.
Previous in DEL OPTN	Deletes any elements you have previously marked by means of the No option in DEL OPTN . Elements deleted in this way cannot be restored through an UNHIDE operation.
Final in DEL OPTN	Deletes (removes) elements. Elements deleted in this way cannot be restored through an UNHIDE operation.

2. Click **Selected** in **HIDE**.
3. Click or box the elements you want to hide or delete.

Unhiding Elements

Any elements that you have hidden by means of the **No Delete** Option can be unhidden.

Unhiding Selected Elements

Elements that have been hidden (but not deleted) can be selectively unhidden.

1. In **ANNOTATION**, click the **UNHIDE** option **Selected**. Any elements previously hidden by means of the **No** option in **HIDE** are now shown in a special highlight color for selection.
2. Click or frame the element(s) you want to unhide.

Sequentially Unhiding Elements

Optionally, you can sequentially unhide elements that have been hidden (but not deleted).

1. In **ANNOTATION**, click the **UNHIDE** option **Sequential**. Any hidden elements are shown in a special highlight color.
2. Select the direction for your sequential **Unhide** operation:

Backward	Undoes your Hide operations in reverse order; i.e. the last HIDE operation is undone first. Optionally, enter the number of backward UNHIDE steps.
Forward	Undoes your HIDE operations in the order in which they were performed; i.e. the first HIDE operation is undone first. Optionally, enter the number of forward UNHIDE steps.
NEXT	Undoes the next HIDE operation in the current direction (Backward or Forward).

3. Any unhidden elements are now shown in a special highlight color.

Changing Colors, Linetypes and Hatches

In the **Annotation** module, you can change the color and linetype of hidden lines and tangent lines. Also, you can change the color, angle, and distance of hatches.

1. In **Annotation**, click the option for the change you want to perform:

In HID LINE	to change the color and/or linetype of hidden lines.
In TAN LINE	to change the color and/or linetype of tangent lines.
In MOD HATCH	to change the color and/or angle and/or distance of hatches.

2. To change these settings, follow the general instructions provided in [Changing the Drawing Environment](#) and [Making Measurements](#) on page 50.

Showing and Storing

When you have completed your work on the Annotation MI drawing file, you may want to see what this drawing would look like in **Annotation** or in Creo Elements/Direct Drafting.

Showing the Drawing in Annotation Mode

To show the drawing in annotation mode, click **Annotation** in **SHOW AS**. This mode reflects your **HIDE** operations.

Showing the Drawing in Creo Elements/Direct Drafting Mode

To show the drawing in Creo Elements/Direct Drafting mode, click **Drafting** in **SHOW AS**. This mode ignores any **No** operations but reflects any **Previous** and **Final** operations performed in **HIDE**.

Storing the Drawing for Further Use in Annotation

To store the drawing for further use in the Creo Elements/Direct Drafting **Annotation** module or in Creo Elements/Direct Annotation:

1. In **ANNOTATION**, click **STORE Anno**.
2. Enter the name of the file in which you want to store the current Annotation MI drawing.

18

Plotting Drawings and Dumping Screens

Creating a Print Configuration	520
Defining the Plotting Parameters	520
Starting a Plot	530
Spool Plotting.....	531
Writing a Creo Elements/Direct Drafting Screendump to an Output File	531
Truecolor Plotting	532
Further Information.....	533

This chapter shows you how to plot drawings and dump screens to a printer/plotter.

Creating a Print Configuration

Pick **CONFIG** at the bottom of the **PLOT** menu. The **PLOT CONFIGURATION** menu appears. It contains the following commands and a table of predefined plot configurations including, for example:

- 'Spool7550': a predefined plot configuration.
- 'Spool7596': a predefined plot configuration.
- 'Laserplot': a predefined plot configuration.
- 'LJ/PostScript': a predefined plot configuration.
- PLOTTER TYPE
- IMAGE QA: specifies a high or low resolution.
- PLOT DESTINATION
- PLOT DEFAULT STRING

Creo Elements/Direct Drafting normally sends plots to a spooler. Depending on the system configuration, the spooler can:

- Continuously send plots to the plotter which plots them automatically.
- Queue up the plots, which means you must initiate each plot.

The spooler can store several drawings at one time so each user can send plots instantly. However, the plotting queue can delay plotting for several minutes (depending on the length of the queue).

To plot your drawing:

1. Press **PLOT**.
2. Set up the desired plot parameters. Pick **POSITION**, **SCALE**, **OUTPUT**, **CONTENTS**, **ROTATE ANG**, **LTYPE LEN**, and **PAPER SIZE** (refer to the appropriate sections in this chapter).
3. If required, select a predefined plot configuration from the **PLOT CONFIGURATION** menu. Refer to [Plot Config Menu on page 526](#).
4. Start the plot by picking **START PLOT**. Refer to [Starting a Plot on page 531](#).

Defining the Plotting Parameters

Before plotting a drawing, you should define exactly what will be plotted and how the drawing will be plotted. The following sections show you how to do this.

Positioning Your Drawing

Select **POSITION**:

- Center: the default option. Creo Elements/Direct Drafting places the bounding box centered on the paper
- Left Justifying the Drawing Left: to position your drawing at the lower left corner prior to printing/plotting. Creo Elements/Direct Drafting will place the bounding box in the lower left corner of the paper

Setting the Plot Scale

This section shows how to set the plotting scale to be used for the subsequent plots.

You can set a plotting scale factor or automatically scale the drawing as large as possible within the limits of your paper.

Entering a Scale Factor

This is the default option. The entire plot will be scaled, but dimension values are not affected.

Figure 271. Operation of Plot Scale on page 521 shows the operation of plot scale.

Figure 271. Operation of Plot Scale

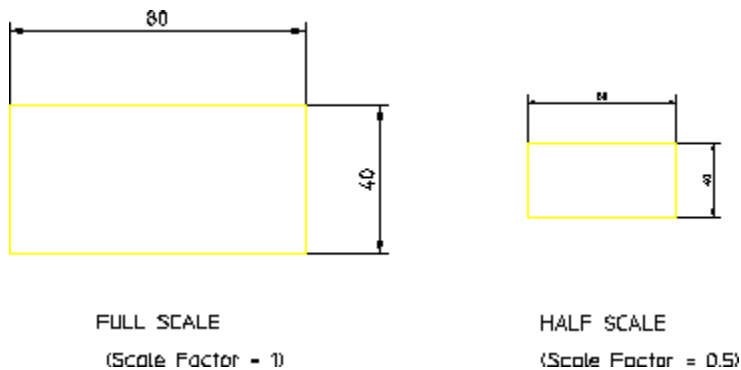

To set the plot scale factor:

1. Press **PLOT**.
2. Pick **SCALE**.

The current plotting scale is displayed:

- In the User Input Line.
- In the menu field immediately to the right of the **SCALE** command.

3. Enter the required plotting scale.

The new scale factor is displayed in the menu field immediately to the right of the **SCALE** command.

If you set the plotting scale such that the drawing is too large for the paper, Creo Elements/Direct Drafting will warn you at the start of a plot by displaying the maximum scale possible. Pressing [Break] will abort the plot and allow you to reset the plot scale. Otherwise, press the space bar and the plot will continue, cutting off elements outside the paper format.

Fitting a Drawing

Press **PLOT** and pick Fit. The subsequent plot of your drawing will be scaled as large as possible within the limits of the paper.

Selecting a Source for Output

The **PLOT** menu OUTPUT options are:

- **All**: to print/plot the entire drawing - irrespective of the current viewport contents. This is the default option.
- **Viewport**: to print/plot the contents of the current viewport.

For example, suppose you are currently viewing a part, and the other parts/elements exist in the same area but are not displayed. If you click **Box**, all the drawing elements existing in the boxed area, both displayed and not displayed, will be plotted.

- **Box**: to print/plot a specific area of a viewport. Click **Pick** and then use your cursor in the drawing viewport to specify two opposite corners of a box. Only the contents of the boxed area will be printed/plotted.

For example, if you are currently viewing a part, only the elements of that part contained within the window of the current viewport will be printed/plotted.

Setting the Image Color

When plotting images (pixmap), you can set the output of the image to be either black and white (B & W) or color (Color).

Setting the Plot Appearance

This section shows how to set the appearance of the plot.

The two CONTENTS options are:

- Drawing
- Curr Show

Contents Drawing Conventions

You can plot the drawing using standard drawing conventions. Drawing lines, dimensions, text and hatching will be plotted. Construction lines, spotlights for parts and so on are omitted.

The drawing will appear as a normal drawing irrespective of the screen status (that is, the plot is unaffected by the SHOW functions).

Press **PLOT** and pick Drawing in CONTENTS and the subsequent plots will conform to standard drawing conventions.

With Current Show Attributes

You can select the conventions used to plot the drawing. Thus any combination of drawing lines, dimensions, hatching, text, or layers can be plotted.

1. Select a viewport in which you want to set up your own drawing conventions.
2. Use the **SHOW** functions together with the SHOW function (in **PARTS 1**) to set up the desired attributes.
3. Press **PLOT**.
4. Pick **Curr Show** in CONTENTS.

The subsequent plots will contain whatever drawing conventions you have selected in the current viewport.



Note

Drawing and Curr Show only determine how the plot will appear. The plotting area is unaffected.

Setting the Rotation Angle

Pick ROTATE ANG to rotate the drawing on the plotter paper. The default angle is 0 degrees.

To set the angle of rotation:

1. Press **PLOT**.
2. Pick **ROTATE ANG**.

The current angle of rotation is displayed using the current angular units:

- In the User Input Line.
- In the menu field immediately to the right of the ROTATE ANG command.

3. Enter the required angle of rotation (in the current angular units).

The new angle of rotation is displayed in the menu field immediately to the right of the ROTATE ANG command.

Setting the Linetype Length

You can set the pattern length for any of the seven broken linetypes. Each broken linetype is a pattern repeated many times to produce a line. Using the LTYPE LEN command you can specify the length of each pattern and thus alter the fineness of the line. [Figure 272. Different Linetype Lengths on page 524](#) shows two DASH_CENTER lines drawn with different linetype lengths. The linetype length is shown arrowed.

Figure 272. Different Linetype Lengths

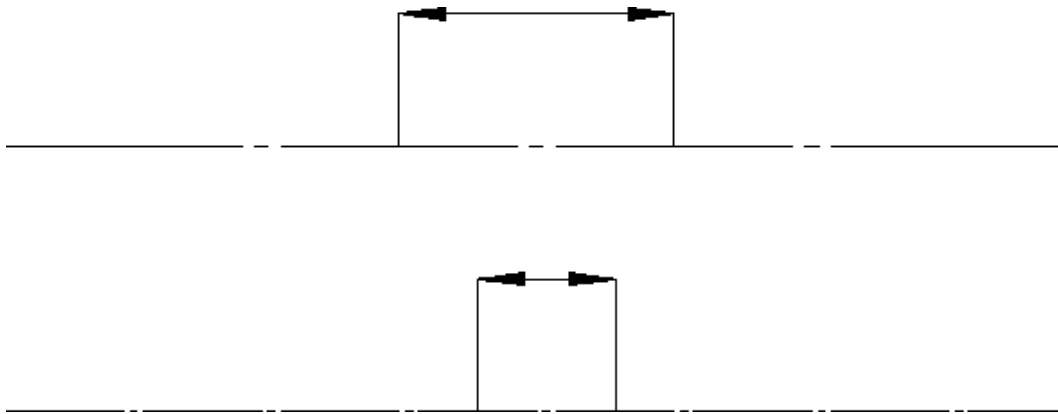

The seven broken linetypes that you can set are:

- DASHED
- LONG_DASHED
- DOT_CENTER
- DASH_CENTER
- PHANTOM
- CENTER_DASH_DASH
- DOTTED

To set the linetype length:

1. Press **PLOT**.
2. Pick LTYPE LEN.
3. Enter the name of the linetype.
4. Enter the required pattern length (the units used are the current length units).

If you wish to change all the linetype lengths:

1. Press **PLOT**.
2. Pick **LTYPE LEN**.
3. Press **ALL**.
4. Enter a single value and all seven broken linetypes will be set to the required length.

Selecting the Paper Size (if GDI printer)

This section shows how to tell Creo Elements/Direct Drafting what size of paper you will be using for your plot.

Each option sets the correct plotter limits for the paper to be loaded in the plotter (a full explanation of hard limits and other plotter terminology can be found in the manual supplied with your plotter).

To set the paper size:

Press **PLOT** and pick the required format in **PAPER SIZE**.

[Table 15. Paper Size Options on page 525](#) gives the eleven paper size options.

Table 15. Paper Size Options

	User Format
A	A4
B	A3
C	A2
D	A1
E	A0

If you want to use paper sizes other than those listed above, pick User Format and enter the following format information:

- Width
- Height
- X offset
- Y offset

All Sheets

When printing an Annotation drawing, you can select **ALL SHEETS ON** to print each Annotation sheet on a separate page. See **ON ERROR** for information on a possible warning when the largest sheet does not fit on your paper.

GDI SETUP

Only for GDI Printers. For generic print drivers, the local paper sizes must be used.

Print Manager Dialog

Set PRINT MGR:

- ON
- OFF

Previewing a Plot

Open the Plot Preview system viewport to see print/plot output on your screen. You can watch how output will look as you work on your drawing, or check it after you select all the necessary print settings.

To preview output:

1. Click **PLOT**.
2. Click a **PREVIEW** color setting for the viewport only:
 - Original: to preview color printer/plotter output.
 - Grey-scaled: to preview black and white printer/plotter with dithering capability output.
 - B&W: to preview black and white printer/plotter output.
3. The Plot Preview viewport appears.

The Plot Preview viewport remains open until you uncheck it in the PLOT dialog box.

Plot Config Menu

To save time when configuring a plot, you can select from the list of predefined plot configurations.

Each predefined configuration contains presettings for the following:

- PLOTTER TYPE
- PLOT DESTINATION
- Delete Old
- Gener Name

Note

If you manually change one of the above settings, the new value will overwrite the predefined value (until you restart Creo Elements/Direct Drafting).

To select a predefined plot configuration:

1. Press **PLOT**.
2. Pick CONFIG.
3. Pick the required configuration in the table of plot configurations.

If you have many entries in the plot configuration table, you can scroll through them with the scroll bar to the right of the table.

Use the scroll bar:

- To scroll to the next page of the plot configuration table: pick the white square at the bottom of the scroll bar.
- To scroll to the previous page of the plot configuration table: pick the white square at the top of the scroll bar.
- To scroll anywhere between the first and last pages: pick anywhere between the top and bottom white squares. Creo Elements/Direct Drafting displays the corresponding part of the plot configuration table.

If you scroll up or down one page, there is always one line overlap between one page and the other.

The scroll bar locator shows your position in the table. For example, if the locator is half-way down the scroll bar then the information you see on the top line (of the table) is halfway through the plot configuration table.

ON ERROR

This option tells you whether you have drawings that do not fit on the selected paper size. In the case of Annotation drawings, the system checks each sheet, finds the largest sheet, and checks whether it matches the chosen plot configuration.

The options are:

- CONT - no warning messages appear.
- STOP - If you are printing Annotation drawings, and the largest drawing does not fit on the selected paper format, you will see the warning, "Plot does not fit on the selected paper area" and you can stop the process.

PLOT OPTN for color

Creo Elements/Direct Drafting plots (prints) to color output devices that are capable of producing color rastering. This feature is available on PostScript Level 2 printers and HP-GL/2 printers. This means, for example that if you have access to an HP DesignJet 650C color printer, you can print any number of colors up to the capability of the printer.

If you plot to a pen-plotter, switch off truecolor plotting. This is because the pen-plotter cannot correctly assign colors (rastered) to pens.

Choose from

- **B&W.** Black and white printing
- **Pen Color.** If you plot to a pen-plotter, switch off truecolor plotting. This is because the pen-plotter cannot correctly assign colors (rastered) to pens.
- **True Color.** The best color palette will be used for printing
- **TC & ST.** True color with screen transformations.



Note

If you have a drawing that contains white color elements and you specify truecolor plotting, the elements are drawn in white. Normally, when sending drawings to a pen-plotter, the white elements on the screen are converted to black (truecolor plotting is switched off).

B/W IMAGE

- Normal: black pixels occur in black color on the paper
- Reverse: black pixels occur in white color on the paper

IMAGE QUALITY

- Low Pix: draft quality
- Best Pix: high quality

Resolutions are defined in the plotdefs file, and can be modified.

Selecting the Plotter/Printer Type

The types of printed output available from Creo Elements/Direct Drafting are:

- Plots, which are plotted on an HP-GL, HP-GL/2, PostScript® plotter

-
- Screen dumps, which are printed on a PostScript or PCL printer.

For a list of supported devices and output possibilities, refer to the configuration manual that corresponds to your operating system.

On start up, the system default plotter type is `7550`.

Use one of the following methods to specify the output device:

- Select a plotter/printer from the preconfigured list, or
- Enter the name of the plotter/printer.

To select a printer/plotter from the preconfigured list:

1. Press **PLOT**.
2. Pick **CONFIG**.
3. Select a device from the list.

Creo Elements/Direct Drafting displays the selected device in the field immediately below the **PLOTTER TYPE** menu entry.

To enter the name of a plotter/printer:

1. Press **PLOT**.
2. Pick **CONFIG**.
3. Pick **PLOTTER TYPE**. Creo Elements/Direct Drafting displays the current device name:
 - In the User Input Line.
 - In the menu field immediately below the **PLOTTER TYPE** menu entry.
4. Enter a valid plotter name enclosed in quotes.

Naming the Plot Destination

You can name the destination to which drawings are plotted. On system startup the default plot destination is `'/opt/CoCreate/ Drafting/spooldir1/p'`.

Note

The plot destination can be a file or the standard input of another process. If the plot destination is a file, Creo Elements/Direct Drafting automatically derives the extension for the output file according to the selected printer/plotter.

To name the plot destination:

1. Click on the appropriate option in **SEND TO** in the **PLOT** menu:

Print Mgr	Sends the output file to the Print Manager for further processing.
Clipboard	Sends the output file to the clipboard.
HPGL GENERIC	Sends the output to an HP-GL file.
HPGL2 GENERIC	Sends the output to an HP-GL2 file.
HPGL2 RTL GENERIC	Sends the output to a generic HP-GL2 RTL file.
PDF	Sends the output to PDF.

- When prompted, enter the name of the file to which you want to write your plot output.

Note

If you have a multi-sheet drawing, type `USE_SHEET_SETTINGS ON` in the User Input Line to automatically set the format and orientation of each sheet based on the sheet size. Refer to the *Creo Elements/Direct Drafting / Creo Elements/Direct 2D Access Programming Reference Guide* for the details of the command.

To set the orientation of a plot, use the `SET_PLOT_ORIENTATION` command with option `LANDSCAPE` or `PORTRAIT`. If you set the paper size such that the height and width are equal, the orientation is set to landscape by default.

Starting a Plot

Use the `START PLOT` command to send your drawing to one of the available spoolers. The spooler queues the drawing and then sends it to a plotter.

To initiate a plot:

- Press **PLOT**.
- Pick **CONFIG**.
- Pick a plot configuration from the table of predefined plot configurations. Refer to [Plot Config Menu on page 526](#). If you wish to define your own configuration, refer to [Selecting the Plotter/Printer Type on page 528](#) and [Naming the Plot Destination on page 529](#).
- Pick MENU 1.

The current plot configuration is displayed in the menu field to the right of the `START PLOT` command.

-
5. Set the plot parameter POSITION, SCALE, OUTPUT, CONTENTS ROTATE ANG, LTYPE LEN and PAPER SIZE (refer to the appropriate sections in this chapter).
 6. Pick START PLOT.
Creo Elements/Direct Drafting sends the drawing to the spooler, which then queues your plot request and sends your plot data to a plotter.

Spool Plotting

Use the SPOOL PLOT command to plot your drawing to a plotfile in the ME spooler. After each drawing has been plotted to a file, the ME spooler will queue the drawing on the selected and configured plotter.

Note

In order to spool plot, the commands PLOTFILE, PLOTTERTYPE, ORIGINAL NAME and GENERATE NAME in the SETUP menu must be set.

Starting a Plot

Pick Start from the screen menu, and the system plots the drawing to a file.

Writing a Creo Elements/Direct Drafting Screenshot to an Output File

You can output your drawings in high-resolution pixel format:

1. Click **File**
2. Click **Export**
3. Follow **Bitmap to File** across and choose an option:
 - BMP
 - JPEG
 - PNG
 - TIFF
4. You will be prompted through the rest of the export.

Prompts are:

Enter PORT, BOX, DEL_OLD or "destination" — to select input

-
- Enter `point`, `CURRENT` or viewport number — to further select after `PORT`
 - Enter lower left and upper right corner of box which is to be dumped — to select after `BOX`

Enter `RESOLUTION` or "`destination`"

- Enter `PAPER_TO_PIXELS` or output image width, height — if you select `RESOLUTION`
 - `PAPER_TO_PIXELS` — recalculates paper format and dpi to your X,Y resolution. You will be prompted for a paper format (A-E, A4-A0) or size, and then you will be prompted for dpi.
 - Enter output image width, height — enter width and height in pixels. Enter -1 for either width or height to retain the ratio of the current viewport and specify the other dimension in pixels.

Possible error messages are:

- Not enough memory available to perform the operation.
- ***The output image size is limited to a maximum of 4/3 billion pixels.

Truecolor Plotting

Creo Elements/Direct Drafting plots (prints) to color output devices that are capable of producing color rastering. This feature is available on PostScript Level 2 printers and HP-GL/2 printers. This means, for example, if you have access to an HP DesignJet 650C color printer you can print any number of colors up to the capability of the printer.

Truecolor plotting can be switched on or off with the **True Color** option in **PLOT OPTN** or by entering the following command:

```
true_color_plotting
```

You can change colors with the `rgb_color` command and then specify the intensities you want.

If you plot to a pen-plotter, switch off truecolor plotting. This is because the pen-plotter cannot correctly assign colors (rastered) to pens.

Note

If you have a drawing that contains elements in the color white and specify truecolor plotting, the elements are drawn in white. Normally, when sending drawings to a pen-plotter, the white elements on the screen are converted to black (truecolor plotting is switched off).

Further Information

For further technical information about plotting or dumping, refer to the Creo Elements/Direct Drafting help system:

Enter `help plot` or `help screen_dump` at the Creo Elements/Direct Drafting command line.

The screen will clear and Creo Elements/Direct Drafting will display further information about plotting or dumping.

19

Grouping

Create a group 535

You can group annotations or parts together. Groups may consists of a single dimension, multiple text elements, parts, and multiple symbols. Each group has one of its elements as the master element.

Creo Elements/Direct Drafting creates one invisible reflow line between each element in a group and its master element. These reflow lines can be shown with either the `SHOW_INV_RTL` or `SHOW_INV_GEO` command. Deleting an invisible reflow line deletes the group. You can change the flyby highlight color of the group box and of the group master element with the `FLYBY_GROUP_MASTER_COLOR` function.

Create a group

To create a group:

1. Click **MODIFY ► MENU 2 ► GROUP**.
2. Enter GLOBAL if you wish to group elements from different parts.
3. Select the master element for the group.
4. Select additional elements to add them to the group.
5. Click **End**.

Add elements to an existing group

To add elements to an existing group:

1. Click **MODIFY ► MENU 2 ► ADD GROUP**.
2. Select an element belonging to the group to which you wish to add.
3. Select elements to add them to the group.
4. Click **End**.

Remove elements from an existing group

To remove elements from an existing group:

1. Click **MODIFY ► MENU 2 ► DEL GROUP**.
2. Select an element belonging to the group to which you wish to add.
3. Select elements to remove them from the group.
4. Click **End**.

Ungroup all elements of a group

To ungroup all elements in an existing group:

1. Click **MODIFY ► MENU 2 ► UNGROUP**.
2. Select an element belonging to the group you wish to ungroup.
3. Click **End**.

Limitations

- A group may contain only one master element.
- If a group contains a dimension, it automatically becomes the master element.
- Each element can belong to only one group.

-
- You cannot add an active part to a group.

20

Managing drawings with Windchill

Activating the Windchill PDM Actions from Creo Elements/Direct Drafting.....	538
Windchill PDM commands	538

The Creo Elements/Direct Drafting and Windchill integration allows you to load, save, and manage data created by Creo Elements/Direct Drafting in Windchill.

Activating the Windchill PDM Actions from Creo Elements/Direct Drafting

1. Register Creo Elements/Direct Drafting with the Windchill Workgroup Manager. To do this, install and start the Windchill Unified Workgroup Manager (UWGM) and set the UWGM server as the primary server.
2. Click **Modules** ► **Windchill WGM** in Creo Elements/Direct Drafting to activate the Windchill Workgroup Manager. The **Windchill WGM** menu is now available in Creo Elements/Direct Drafting.

Windchill PDM commands

The following table explains the PDM commands that are inserted into Creo Elements/Direct Drafting when connected to the Windchill Workgroup Manager.

Action	Menu Location in Classic User Interface	Description
Open from Windchill	Windchill WGM ► FILE ► OPEN WT	Presents the Open from Windchill window. By default, the contents of your active workspace are displayed. You can also navigate to the server common space to select an object to open.
Save to Workspace	Windchill WGM ► FILE ► SAVE WT	Presents the Save to Workspace window. Upon execution of the save, the document is uploaded to the server-side workspace.
Check out	Windchill WGM ► FILE ► CHKOUT	Checks that the current drawing is not already checked out. If not, checks out the current document to the workspace.
Revise and Check out	Windchill WGM ► FILE ► REV&CHKOUT	Checks that the current drawing is not already checked out. If not, creates a new revision of the current file and checks the new revision out to the workspace, replacing the earlier revision in the workspace and in Creo Elements/Direct session.
Undo Check out	Windchill WGM ► FILE ► UNDOCHKOUT	Cancels the check out of the current document.

Action	Menu Location in Classic User Interface	Description
		 Note If the document was checked out via the Revise and Check out action, the higher revision label is maintained.
Custom Check In	Windchill WGM ► FILE ► CUSTCHKIN	Accesses the Check In page and allows you to change check in options.
Auto Check In	Windchill WGM ► FILE ► AUTOCHKIN	Automatically checks in the current file to the commonspace.
Load File from Windchill	Windchill WGM ► FILE ► LOAD WT	Presents the Open from Windchill window, allowing you to navigate to another document with drawing geometry to load into the current drawing.
Load Frame from Windchill	Windchill WGM ► FILE ► LOAD FRAME	Presents the Open from Windchill window, allowing you to navigate to a library containing frames and select a frame to load into the current drawing. The default location shown can be defined by the Windchill server preference, Default Drawing Frame Location .
Save Frame to Windchill	Windchill WGM ► FILE ► SAVE FRAME	Presents the Save to Workspace window, allowing an administrator to save a new drawing recognized as a frame to an appropriate library workspace.
Text Reference	Windchill WGM ► TEXT REFS	Calls or displays a submenu for text references enabling a user to assign, unassign, or update text references to document attributes. In addition, actions are available to display references, values, or a table of name-value pairs.
Workgroup	Windchill WGM ► MANAGERS	Opens the Windchill Workgroup

Action	Menu Location in Classic User Interface	Description
Manager	► WORKSPACE	Manager (if closed); accesses the Workgroup Manager (if open).
Server Management	Windchill WGM ► MANAGERS ► SERVER MGT	Opens the Server Manager window, where you can view or change Windchill servers and server active workspaces.
Event Management	Windchill WGM ► MANAGERS ► EVENT MGT	Opens the Event Manager on the current server.
Update	Windchill WGM ► UPDATE	Checks the server for a later iteration. If one is found, replaces the drawing in session and in the workspace with the latest server iteration. An UPDATE action also updates all drawing text references.
View Drawing Information	Windchill WGM ► FILE ► INFO	Opens the server information page (workspace view) for the drawing in session.
Windchill Workgroup Manager Help	Windchill WGM ► HELP	Opens the Windchill Workgroup Manager Help Center.

For more information on the Windchill PDM commands, see the Windchill WGM help from the Creo Elements/Direct Drafting user interface.

21

Customizing

Assigning Creo Elements/Direct Drafting Commands to Mouse Buttons	542
The Creo Elements/Direct Drafting Toolbox	542

Assigning Creo Elements/Direct Drafting Commands to Mouse Buttons

To facilitate your design tasks, you can assign frequently used Creo Elements/Direct Drafting commands to the buttons of your mouse. To execute such a command, hold down the [Shift] key and press the mouse button. The standard mouse actions and the `DEFINE_MOUSE_KEY` statements for each mouse button are specified in the following table.

Left Button	Middle Button	Right Button
[Ctrl] Pan	–	Zoom
[Shift] <code>DEFINE_MOUSE_KEY_1</code>	<code>DEFINE_MOUSE_KEY_2</code>	<code>DEFINE_MOUSE_KEY_3</code>
Standard Click or copy text (from another window)	Paste text (on the user input line or editor)	Emulates the [Enter] key

Example: Drawing a Rectangle by Pressing the Left Mouse Button

To assign the command for drawing a rectangle to the left mouse button:

1. On the user input line, type in:
`DEFINE_MOUSE_KEY 1 'line rectangle 0,0 50,40'`
2. Press [Enter]

The next time you press [Shift] + left mouse button, the line rectangle command string appears on the user input line. Press [Enter] to draw the rectangle.

The Creo Elements/Direct Drafting Toolbox

The Creo Elements/Direct Drafting screen-only version provides a special window from which you can run, view, and administer macros. Up to 24 macros can be assigned to the Toolbox window and you can define any number of macro-sets that can be called into Toolbox. The Toolbox window is shown in [Figure 273. Toolbox Window on page 543.](#)

Figure 273. Toolbox Window

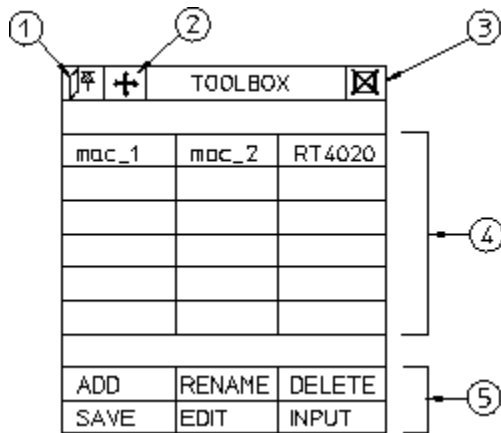

To display the Toolbox window, click **TOOLBOX** (in the interrupt-function block). The components of the Toolbox window are:

- 1 Pin the Toolbox
- 2 Move the Toolbox
- 3 Close the Toolbox
- 4 Macros
- 5 Administering Toolbox

Recording a Macro

To start recording a macro:

1. Pick ADD.

Numbers appear in the boxes to help you identify the correct box. If macros are already assigned, their names are shortened to make space for the box numbers.

2. Pick one of the 24 macro boxes.
3. Enter a name (up to six characters long and between quotes ' ').
4. Pick or enter a set of commands (the system records all your actions).
5. Pick END from the Toolbox menu.

The system stops recording the macro and displays the macro name in the box you assigned to it.

Example

This example shows you how to record a macro named RT4020 that draws a rectangle and dimensions it (rectangle size is 40x20mm). The macro is assigned to box number 3.

Before you start to record this macro, make sure Creo Elements/Direct Drafting is displaying the CREATE menu and the Toolbox window.

-
1. Pick ADD.
 2. Pick box number 3.
 3. Enter `RT4020`
 4. Pick Rectangle in CREATE.
 5. Enter 0,0
 6. Enter 40,20
 7. Pick END.

The macro is now defined.

Running a Macro

To run a macro, pick the macro name from the Toolbox window.

Renaming Macros

To rename a macro:

1. Pick RENAME.
2. Pick the required macro.
3. Enter the new name.

Deleting Macros

To delete a macro:

1. Pick DELETE.
2. Pick the required macro.

Editing Macros

Once you have created a macro, you can modify its contents using the EDIT command. For example, suppose you want to change the size of the rectangle you created in [Recording a Macro on page 543](#) to measure 38x22 instead of 40x20. To do this, first pick EDIT and then pick the macro RT4020. Creo Elements/Direct Drafting displays the macro string to be edited. Type over the old values with the new and press [Enter].

The next time you use this macro, the new rectangle is drawn. (You may wish to change the macro's name to reflect the new size.)

Loading Macro-Sets

Although Toolbox lets you display a maximum of 24 macros, you can group macros together into a file. Each file can contain up to 24 macros that can be loaded by Toolbox. For example, if you have a file called `tb_rectangle` containing the macros:

```
RT4020  
RT4025  
.  
.  
.  
RT5020
```

you can tell Toolbox to use this file by picking INPUT and then specifying the filename `tb_rectangle`.

Note

- The Toolbox window is a fixed size. Although you can reposition it around the screen, you cannot change its size.
 - If you interrupt a command sequence, you must recall Toolbox from the main menu in order to get the original Toolbox menu back again.
-

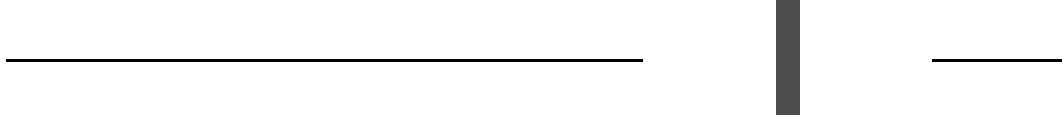

Unicode

1

Introduction

Creo Elements/Direct Drafting's different internal and external encoding schemes were Unicode incorporated for version 2007. Unicode allows text and symbols from all languages to be consistently represented and manipulated by computers.

All textual and string data processed by Creo Elements/Direct Drafting is held internally in Unicode (UTF-8) encoding. That means most of Creo Elements/Direct Drafting's functionality processes user input from almost any language, and string data from different languages can be mixed. For example, it is now possible to have German, Japanese, and Russian characters within a single string, such as a part name.

Drafting's font list contains all the Creo Elements/Direct true type fonts that are dynamically converted to internal font format when referenced. An appropriate font that contains all desired characters must be selected to display texts and dimension texts correctly. Fonts containing characters from the whole Unicode range are relatively rare, and they usually contain the word Unicode in their name (for example, Arial Unicode MS).

Symbols are a special Creo Elements/Direct Drafting feature and display with `hp_symbols` and `hp_symbols2` fonts. They can still be composed in old-style escape sequences (`#15#XY#16`) but for compatibility with Unicode are mapped to a private-use Unicode area [E000-E1FF]:

- `15#XY#16` → `0xE000 + XY`
- `30#XY#31` → `0xE100 + XY`

MI file format

Vesion 3.20 MI files are encoded in Unicode (UTF-8). Files stored to older MI versions are encoded as before, depending on the current locale. When loading older MI formats, the Creo Elements/Direct Drafting loader uses the information recorded in the info section (~1) of the MI file. MI formats without encoding information in their info sections are treated as if encoded in ROMAN8 or SJIS (Japanese locale).

2

Macro file encoding

Old macro files did not contain any encoding information. They were assumed to be encoded for current locales (e.g. ROMAN8 for English and SJIS for Japanese locales). However, this causes problems when using the same macros in different locales.

Version 2007 supports macro Unicode but maintains backward compatibility. We recommend you change old macro files such that their encoding is explicitly specified with the `DEFINE_ENCODING` directive.

Text macro files containing Unicode UTF-8 or UTF-16 BOMs (Byte Order Markers), supported by most popular Windows text editors, are read as Unicode.

Files containing the `DEFINE_ENCODING` directive are always read in the specified encoding. Otherwise they are treated as old macro files and encodings are locale dependent:

- SJIS for Japanese
- BIG5 for traditional Chinese
- GB2312 for simplified Chinese
- ROMAN8 for all else

Limitations

The displaying of Unicode texts is limited. Features such as combining characters, Arabic cursive connection, and bidirectional algorithm are not fully implemented.

`CHR`, `NUM` and `#` still work in old locale-dependent internal encodings (ROMAN8 & SJIS). They return different results in different locales. They are obsolete; their use is only for maintaining backward compatibility. For example,

((CHR 154)+(CHR 223)) or its equivalent (#154#223) displays a Japanese character with Unicode code 22756 (hex 58E4) on a Japanese locale and two Latin characters on other locales. To avoid problems and to display the same character regardless of locale, use Unicode versions of these functions: (UCHR 22756), (UCHR '58E4'), #u22756, or #ux58E4.

Combinations of # and CHR to compose 2-byte characters and symbols are not allowed. For example, ((CHR 154)+#223) does not work.

Strings that begin with (CHR 255) are icons and are not encoded in UTF-8. Pre-2007 CoCreate Drafting versions let you compose icons using a large variety of combinations (for example #255'abc'#212+CHR 12). In version 2007, only CHRs can be used to compose icons.

MI files of versions prior to 2.90 that do not contain encoding information in their info section (~1) load correctly only if loaded in the same locale as they were drawn. For example, you have 2 options to correctly load a Japanese MI file of version 2.80 in English Creo Elements/Direct Drafting:

1. Load the file in japanese locale and store it back in new format:
 - CHANGE_LOCALE 'ja'
 - LOAD 'japanese.mi'
 - STORE MI ALL DEL_OLD 'japanese.mi'
 - CHANGE_LOCALE 'en'
2. Load the MI file in a text editor and manually add section ~1 at the beginning of MI file:
 - #~1
 - ENCODING:SJIS
 - Such files load correctly in any locale.

AI modules call internal Creo Elements/Direct Drafting functions and use strings in internal encoding. Before CoCreate Drafting 15.00 (2007) these strings were encoded in ROMAN8 or SJIS, depending on locale. Compatibility is maintained only for characters in range [0, 127]. If AI modules use characters in a different range, they must be changed and recompiled to support UTF-8.

3

File names encoding

In CoCreate Drafting 2007, file names display in the same fashion as other Windows applications. Prior to 2007 they were shown in the internal encoding, which was different and dependant on locale. Files names were consequently shown differently if extended characters were used.

You can set the MEEXTFN option in the `.ini` file to zero to keep the old behavior.

4

Changed font concept

CoCreate Drafting 2007 does not distinguish between 1-byte and 2-byte fonts (in terms of default settings or text properties). Because Drafting now has Unicode support, there is just one current font at a time and each text and dimension text has just one assigned font.

CoCreate Drafting 2007 includes new default fonts which have been combined from the old 1- and 2-byte definitions:

- `osd_default` combines `hp_i3098_v` and `hp_kanj2_c`
- `osd_default2` combines `hp_i3098_c` and `hp_kanj2_c`
- `osd_default3` combines `hp_d17_v` and `hp_kanj2_c`

When loading old 2D files with texts or dimension texts using characters from 1- and 2-byte fonts (fonts that are not already included in any of the `osd_default` fonts), Drafting automatically combines the 2 fonts into a single font containing the character definitions from both fonts. It names them "1-byte=font name"#"1-byte=font name".

You can combine those fonts (1- and 2-byte fonts) into a single font using a new command `MERGE_TWO_FONTS`.

True Type fonts converted to Creo Elements/Direct Drafting fonts contain all defined characters. Separate symbol fonts are used

Index

A

- adding
 - spline, 145
 - tolerance, 286
- adding new postfix, 233
- adding new prefix, 232
- adding new tolerance, 234
- adding symbols to drawing, 346
- alignment symbols, 351
- appending text, 352
- arc
 - by center and end points, 127
 - by center and radius, 127
 - by diameter, 128
 - by mid-point and radius, 128
 - by three points, 127
- assigning
 - z-value, 426
- automatic
 - automatic, 309
- automatic hatching, 307
- automatic splitting, 309
- autosave command, 25

B

- balloon frame, 336
- beeper
 - switching on or off, 27
- box frame, 337
- B/W image, 528

C

- cancel a dimension text edit, 293
- CANCEL command, 48

- canceling
 - a command or function, 48
 - hatch pattern, 315
- catalog
 - current directory, 484
 - items, 490
 - listing items, 485
 - named directory, 485
 - selecting entries, 486
 - sorting, 489
 - view, 484
- catching lines, 253
- centerline dimensions, 199
- chamfer
 - at an angle, 136
 - at distance from vertex, 136
 - by two distances, 136
 - by two points, 135
 - drawing, 135
- change
 - color, 517
 - color of pixels, 474
 - color scheme, 506
 - dimension color, 270
 - dimension location and orientation, 284
 - dimension text format, 269
 - dimension text frame, 284
 - dimension tolerance, 285
 - dimension-line pensize, 274
 - fonts, 341
 - hatch, 315
 - hatch angle, 316
 - hatch color, 317
 - hatch distance, 316
 - hatch match point, 316

- hatch pattern, 317
- hatches, 517
- hidden line color, 442
- hidden linetype, 442
- line attributes, 269
- linetype, 317
- lintypes, 517
- part into symbols, 407
- terminator position, 274
- terminators, 270
- text, 337
 - text adjust, 339
 - text angle, 338
 - text attributes, 276
 - text block line spacing, 338
 - text character spacing, 344
 - text font, 334
 - text frame, 340
 - text ratio, 339
 - text size, 338
 - text slant, 339
- change dimension prefix, 288
- check
 - z-values, 428
- circle
 - by center and circumference point, 125
 - by diameter, 126
 - by radius and two elements, 125
 - by three points, 125
- clean a drawing, 175
- CLEAN command, 175
- clearing a style, 296
- clearing current postfix, 233
- clearing current prefix, 233
- clearing current tolerance, 236
- color filter, 241
- coloring faces, 437
- command
 - PART, 373
- commands
 - canceling, 48
 - commonly used, 35
 - confirming, 48
 - ending, 48
 - undoing, 48
- common interrupt functions, 232
- concentric
 - arcs, 128
 - circles, 125
- CONFIRM command, 48
- construction
 - circles, 108
 - geometry, 105
 - lines, 105
- construction line
 - at an angle, 107
 - bisecting, 107
 - bisecting an angle, 107
 - by two points, 105
 - horizontal, 105
 - parallel, 106
 - perpendicular, 106
 - tangent from point to circle, 107
 - tangent to two circles, 108
 - vertical, 106
- construction symbol, 111
- Contour level, 45
- contours
 - selecting, 44
- convert
 - text to geometry, 345
- converting splines, 153
- COPILOT command
 - SETUP menu, 29
 - switching on and off, 33
- copilot functionality, 94
- copy
 - shared parts, 399
 - text, 331
- Copy Contour, 47
- copy directories, 494
- copy directories using recursive, 494

-
- copy files using selection mechanism, 492
 - copy options, 496
 - counting parts, 403
 - create
 - contour, 174
 - crank assembly, 443
 - datum dimensions, 203
 - detail drawing, 387
 - directories, 500
 - final engine assembly drawing, 381
 - frame assembly, 419
 - further assemblies, 381
 - group, 535
 - hatch pattern, 313
 - parallel perspective, 168
 - parts, 386
 - print configuration, 520
 - sheet, 515
 - subpart, 387
 - wrist assembly, 380
 - Create
 - new Creo Elements/Direct Drafting instance, 483
 - creating
 - centerline, 129
 - hyperbolas and parabolas, 140
 - polyline, 137
 - reference line, 132
 - symmetric elements, 130
 - creating an assembly drawing, 378
 - creating points, 120
 - Creo Elements/Direct Annotation, 507
 - change element, 514
 - display sheet browser, 511
 - hide difference, 514
 - hiding hidden lines, 512
 - hiding tangent lines, 513
 - limitation, 509
 - load drawing, 511
 - modify views, 512
 - move dimension, 514
 - preserve modification, 509
 - rules, 508
 - select current view, 512
 - select sheet browser, 511
 - sheets, 515
 - show difference, 513
 - showing hidden lines, 513
 - showing tangent lines, 513
 - views, 512
 - Creo Elements/Direct Drafting
 - activating Windchill PDM actions, 538
 - basic working methods, 20
 - common definitions, 20
 - customization, 541
 - dimensioning, 186
 - fonts, 335
 - getting started with, 17
 - preparing the drawing environment, 510
 - toolbox, 542
 - user interface, 17
 - writing screendump to an output file, 531
 - current directory command, 465
 - current z-value, 431
 - cutting
 - middle section, 174
- ## D
- database-matching, 225
 - datum dimension Text, 251
 - datum dimensioning, 203
 - datum stepping, 251
 - define
 - plot parameters, 520
 - defining
 - your own units, 32
 - defining softkeys, 232
 - delete
 - elements, 24

- layers, 455
- delete command, 36
- delete cover faces, 435
- delete operation, 48
- deleting
 - elements, 36
 - general, 36
 - hatching, 36
 - points, 151
 - tolerance, 286
- deleting hatching, 310
- Deleting Macros, 544
- deleting symbols, 347
- diameter dimensioning, 211
- dimension
 - modify, 297
- dimension assignment features, 189
- dimension geometry, 183
- dimension lines, 184
- dimension text, 181
- dimension text frames, 184
- dimension underlining, 292
- dimension value, 182
- dimensioning
 - angle, 217
 - arc, 216
 - between parts, 191
 - chamfer, 217, 220
 - datum, 203
 - details parts, 191
 - horizontal, 197
 - on layers, 191
 - parallel, 197
 - parallel to reference line, 198
 - perpendicular, 197
 - preparation, 192
 - single, 194
 - using tangents, 212
 - vertical, 197
 - with GEO SENS, 222
 - with SCAN, 224
- dimensioning commands, 187
- dimensioning commands and functions, 187
- dimensioning database, 225
 - adding entries, 228
 - assigning, 229
 - deleting entries, 228
 - exporting entries, 230
 - saving and loading, 230
 - unloading, 231
- dimensioning drawing, 180
- dimensioning elements, 190
- dimensioning functions, 187
- dimensioning standards, 192
- dimensions
 - centerline, 199
 - chain, 199
 - diameter, 211
 - horizontal, 202
 - parallel, 201
 - parallel to a reference line, 203
 - perpendicular, 202
 - radii, 209
 - vertical, 202
- divide
 - splines, 155
- DRAW SCALE set command, 33
- drawing
 - arcs, 126
 - chamfers, 135
 - circle, 124
 - closed spline, 145
 - ellipses, 138
 - fillets, 135
 - isometric view, 171
 - leaders and terminators, 333
 - lines, 121
 - mirror, 165
 - open spline, 144
 - parallel contours, 158
 - rotate, 164
 - similar elements, 168

- spline by specifying control points, 144
- splines, 142
- using layers, 450
- drawing a lever using construction geometry, 110
- drawing dimension lines, 253
- drawing lines, 121
- drawing modifiers, 353
- drawing scale
 - maximum, 33
 - setting, 33
- drawing symbols, 349
- dual dimensioning, 231
- dumping hidden lines, 443
- dumping screens, 519
- duplicating elements in other layers, 453
- DXF/DWG and IGES 2D Translation, 345

E

- EDIT ENV command, 29
- editing
 - tolerance, 285-286
- editing font, 343
- editing text, 291
- element
 - adding to your selection, 41
 - identifying, 21
- elements
 - boxing, 41
 - dividing fractionally, 134
 - drawing, 98
 - enclosing within a polyline, 42
 - hiding or deleting, 516
 - merging, 134
 - move, 162
 - offsetting, 99
 - preselecting, 47
 - removing them from your selection, 41

- selecting, 38
- selecting all, 42
- trimming, 172
- unhiding, 516
- ellipse
 - by center and two points, 139
 - by center, angle and radii, 138
 - by focus and points, 139
 - by vertices and point, 138
 - drawing, 138
- END command, 48
- ending
 - a command or function, 48
- entering
 - a value, 21
- environment, 30
- environment file
 - preparing, 28
 - saving, 30
 - setting a drawing frame, 32
 - setting the current units, 31
- environmental file
 - editing, 29
- exporting bitmap file, 470
- extension lines, 184

F

- faces?, 415
- file browser menu, 466
- file browser options, 470
- file names, 463
- file names encoding, 552
- file organization, 463
- file path name, 464
- files
 - edit, 500
 - inputting, 501
 - saving, 501
- fillets
 - changing, 135
 - drawing, 135
- filter

- clearing the selection, 242
- fit a drawing, 522
- fixing menus, 24
- flag frame, 337
- font editor, 341
- form symbol, 349
- frame
 - loading a drawing frame, 32
 - option, 32

G

- gathering dimensions into other parts, 391
 - with all above, 392
 - with all below, 392
- gathering elements into other parts, 389
 - with copy, 390
 - with delete old, 389
- gathering parts, 392
 - with copy, 393
 - with delete old, 393
- GDI printer, 525
- GDI setup, 526
- generate
 - hidden lines, 413, 440
- generating all faces, 428
- generating faces, 427, 433
 - automatically, 433
 - manually, 434
- generation mode, 418
- GEO command, 43
- geometric tolerance group, 347
- geometric tolerancing symbols, 347
- geometry
 - angular construction, 97
 - circular construction, 98
 - horizontal and vertical construction, 97
- group
 - add elements, 535

- create, 535
- limitations, 535
- remove elements, 535
- ungroup elements, 535

grouping, 345, 534

H

- handling parts and assemblies, 372
- hatch color, 313
- hatch distance, 311
- hatch linetype, 312
- hatch to geometry, 309
- hatching
 - around dimension text, 318
 - around text, 318
 - automatic, 307
 - manual, 307
- hatching a drawing, 306
- hatching a drawing area, 307
- help
 - general, 25
- HELP command, 26, 48
- hidden lines
 - generate, 413
 - introduction, 414
- hidden lines modes, 418
- hide and show image, 472
- hiding, deleting, unhiding, 516
- history table, 469
- horizontal copy, 163
- horizontal move, 163
- how to use selection, 488
- hyperbolas and parabolas
 - creating, 140

I

- identify files, 464
- identifying
 - a point, 21
 - an element, 21
- image quality, 473, 528

- import a bitmap file, 471
- indicating
 - a point, 21
- INFO command, 43
- infos, 455
 - add, 456
 - change, 459
 - delete, 458
 - edit, 457
 - listing, 460
- initiating
 - part, 385
 - subpart, 386
- intersection testing, 194

K

- keeping cornets, 136

L

- language
 - switching, 26
- LAYER command, 43
- layers and infos, 449
- limit tolerances, 182
- line, 19
 - by two points, 121
 - horizontal, 122
 - index, 19
 - parallel, 122
 - perpendicular, 123
 - prompt, 19
 - tangent from point to arc or circle, 123
 - tangent to two arcs or circles, 123
 - user input, 19
 - vertical, 122
 - with length and angle, 124
- line attributes, 269
- line drawing set, 119
- linesize filter, 240
- linetype filter, 240

- listing, 31
 - environment, 31
- listing compressed MI files, 467
- listing fonts, 340
- load
 - backup drawing, 441
- load a drawing, 477
- load a drawing or part, 477
- load a part, 478
- load a subpart, 478
- load a workfile, 479
- load an HPGL file, 479
- load and store drawing, 466
- load fonts
 - automatically, 336
- LOAD FRAME command, 32
- load table entry, 296
- load value, 431
- loading
 - a standard drawing frame, 32
- loading fonts, 335
- location symbol, 351
- loop slope filter, 239

M

- macro file encoding, 550
- macro-sets, 545
- macros
 - deleting, 544
 - editing, 544
 - loading, 545
 - recording, 543
 - renaming, 544
 - running, 544
- making the parent part active, 386
- managing drawings with Windchill, 537
- manual hatching, 307
- match point, 311
- menu
 - pinning, 24

- positioning, 24
- MI file format, 549
- mirror
 - about horizontal, 166
 - about two points, 165
 - about vertical, 166
 - center point, 166
 - drawing, 165
 - text, 332
- modify
 - drawing, 160
 - layers, 455
 - sheet, 515
 - spline angle, 152
 - splines, 148
 - text, 330
 - using selection, 162
- modify operation, 48
- modify picture, 475
- mouse
 - dynamic, 20
- move
 - elements, 162
 - horizontal, 163
 - multiple, 164
 - vertical, 163
- moving
 - text, 331
- moving elements between layers, 453
- moving symbols, 347
- multiple assignment methods, 189
- multiple copy, 164
- multiple move, 164

N

- naming plot destination, 529

O

- options
 - parts list, 405
- overlapping viewports, 23

P

- PART command, 43, 373
- part editor, 401
- part name
 - rules, 377
- part structure, 375
- parts, 375
 - advantages, 378
 - delete, 382
 - edit, 384
 - modify, 383
 - renaming, 408
- parts list, 403
- parts list options, 405
- pensize filter, 240
- picture browser, 476
- picture transparency, 475
- pinning menus, 24
- plot
 - spool, 531
 - start, 530
- plot config menu, 526
- plot option for color, 528
- plot output, 522
- plotting drawings, 519
- plotting hidden lines, 443
- plus and minus tolerances, 182
- point
 - identifying, 21
 - indicating, 21
- polyline
 - creating, 137
 - smashing, 138
- position of points, 149
- positioning
 - drawing, 520
- positioning menus, 24
- postfix, 183
 - add, 291
 - change, 290
 - delete, 291
 - edit, 290

Postfixes,, 236
Predefining, 236
Predefining Prefixes, Postfixes,
 Superfixes, Subfixes, and Tolerances,
 236
prefix, 181
 add, 289
 change, 288
 delete, 290
 edit, 289
Prefixes, 236
preview a plot, 526
PREVIEW command, SETUP menu,
 30
previewing drawings, 469
print manager, 526
printing file browser, 468
producing parts tree, 404
profile symbol, 350
project reference point, 131
prompt
 line, 19
purging files directories, 496

R

radii dimensioning, 209
redraw
 hidden mode, 436
 normal mode, 437
reset colors, 505
resetting
 default color for hidden line, 442
revision checking, 502
rotate
 about a center, 164
 by reference point, 165
 drawing, 164
 text, 331
rotating drawing, 164
runout symbol, 352

S

SAVE ENV command, 30
save fonts, 336
save STYLE table, 296
scale factor, 521
scaling parts, 411
scrollbar position, 468
scrolling file browser, 471
search command, 465
selecting
 dimension offset, 250
 plotter/printer type, 528
 terminator attributes, 245, 271
 text attributes, 278
selecting for deletion, 43
selection filter
 naming, 242
 saving and loading, 242
selection filtering, 237
 enable and disable, 238
 geometry, 238
 setting up, 238
setting
 active layer, 453
 active part, 377
 all z-values, 428
 current offset, 424
 cursor delay time, 97
 default color for hidden line, 442
 default face color, 437
 default hidden linetype, 441
 dimension attributes with style table,
 293
 dimension catch range, 267
 dimension geometry, 185
 dimension geometry color, 248
 dimension line pensize, 248
 dimension location, 264
 dimension offset, 275
 dimension orientation, 264
 dimension text format, 259
 dimension text frame, 263

- dimension text offset, 265
- dimension text space, 266
- dimension units, 261
- dimensioning attributes, 243
- font, 334
- hatch linetype and color, 312
- hatch parameters, 310
- hatch patterns, 313
- hidden lines display, 441
- image color, 522
- line attributes, 243
- linetype length, 524
- minimum space, 252
- offset point, 249, 274
- paper size, 525
- part reference point, 408
- plot appearance, 522
- plot scale, 521
- rotation angle, 523
- snap values, 97
- standard hatch pattern, 319
- symbol size, 347
- symbol type, 349
- terminator size and type, 333
- terminators, 243
- text attributes, 254
- text distances, 185
- text frame, 336
- z-values, 424
 - z-values in a complete part, 427
- setting an element's z-value, 427
- setting default z-value, 431
- setting load value, 432
- settings
 - auto-placement, 193
- SETUP menu
 - copilot, 28
- sharing parts, 398
- show block with layers, 454
- Showing Layer Color, 455
- Showing Layers On & Off, 454
- showing parts, 395
 - with all, 395
 - with part, 395
 - with part boxed, 396
- smashing subparts, 396
- spline angle, 146
- SPLINE command, 144
- spline components, 143
- spline order, 146
- splitting
 - elements, 133
 - elements automatically, 133
 - single elements in a box, 134
 - splines, 154
- spotlighting parts, 407
- status line color, 19
- store a drawing, 480
- store a drawing file in HPGL format, 482
- store a workfile, 482
- store compressed MI format, 481
- storing
 - the workfile, 25
- storing and showing, 517
- storing, loading and filing, 462
- stretch a drawing, 170
- STYLE table, 293
- Subfixes, 236
- Superfixes, 236
- surface symbols, 356
- switching COPILOT on/off, 33
- Switching Hidden Lines On/Off, 443
- symbol
 - alignment, 351
 - drawing target and revision, 354
 - form, 349
 - location, 351
 - profile, 350
 - runout, 352
- symmetry-style dimensions, 198

T

table entry
 add, 294
 delete, 296
 edit, 296
Text
 edit, 291
text abbreviation, 111
TEXT command, 43
tolerance, 182
 add, 286
 convert, 286
 delete, 286
 edit, 285
 type, 286
Tolerances, 236
top part, 375
truecolor plotting, 532

U

undo faces, 435
unicode
 limitations, 550
Unicode, 548
unique part, 411
units
 setting, 31
UNITS command, 31
unshared parts, 400
upper and lower tolerances, 183
user interface, 18
using overdraw, 120

V

VERTEX command, 42
vertical copy, 163
vertical move, 163
view
 range of z-values, 438
view mode, 418

viewing parts, 406
 with parent, 407
 with part, 406
 with top, 406
viewport, 23
 general description, 23

W

weld, 367
welding symbols, 363
 construction lines, 366
 positioning, 364
 setting up, 367
 stretching, 366
wildcards, 487
Windchill, 537
Windchill PDM commands, 538
workfile
 how to store, 25
working
 basic methods, 20
working directory, 468

Z

z-value
 assigning, 426
 assigning to a shared part, 426
 setting, 424
z-value deleting, 426
z-value positioning an element, 426
z-values, 416
z-values and shared parts, 418