

# SINGLE PHASE AC CIRCUITS

## Definition of Alternating Quantity

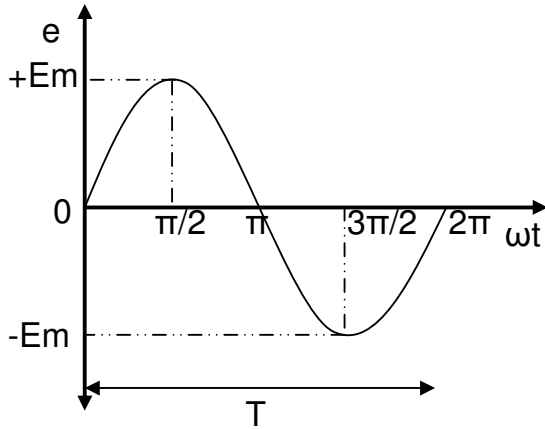

An alternating quantity changes continuously in magnitude and alternates in direction at regular intervals of time. Important terms associated with an alternating quantity are defined below.

### 1. Amplitude

It is the maximum value attained by an alternating quantity. Also called as maximum or peak value

### 2. Time Period (T)

It is the Time Taken in seconds to complete one cycle of an alternating quantity

### 3. Instantaneous Value

It is the value of the quantity at any instant

### 4. Frequency (f)

It is the number of cycles that occur in one second. The unit for frequency is Hz or cycles/sec.

The relationship between frequency and time period can be derived as follows.

Time taken to complete  $f$  cycles = 1 second

Time taken to complete 1 cycle =  $1/f$  second

$$T = 1/f$$

## Advantages of AC system over DC system

1. AC voltages can be efficiently stepped up/down using transformer
2. AC motors are cheaper and simpler in construction than DC motors
3. Switchgear for AC system is simpler than DC system

## Generation of sinusoidal AC voltage

Consider a rectangular coil of  $N$  turns placed in a uniform magnetic field as shown in the figure. The coil is rotating in the anticlockwise direction at a uniform angular velocity of  $\omega$  rad/sec.

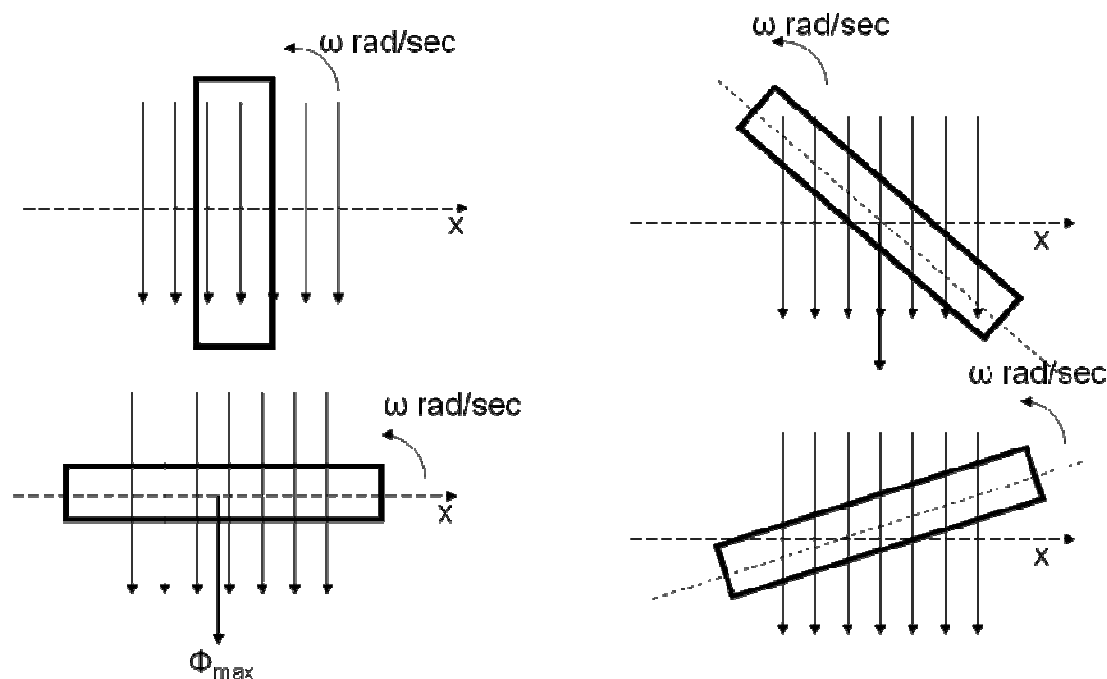

When the coil is in the vertical position, the flux linking the coil is zero because the plane of the coil is parallel to the direction of the magnetic field. Hence at this position, the emf induced in the coil is zero. When the coil moves by some angle in the anticlockwise direction, there is a rate of change of flux linking the coil and hence an emf is induced in the coil. When the coil reaches the horizontal position, the flux linking the coil is maximum, and hence the emf induced is also maximum. When the coil further moves in the anticlockwise direction, the emf induced in the coil reduces. Next when the coil comes to the vertical position, the emf induced becomes zero. After that the same cycle repeats and the emf is induced in the opposite direction. When the coil completes one complete revolution, one cycle of AC voltage is generated.

The generation of sinusoidal AC voltage can also be explained using mathematical equations. Consider a rectangular coil of  $N$  turns placed in a uniform magnetic field in the position shown in the figure. The maximum flux linking the coil is in the downward direction as shown in the figure. This flux can be divided into two components, one component acting along the plane of the coil  $\Phi_{\max}\sin\omega t$  and another component acting perpendicular to the plane of the coil  $\Phi_{\max}\cos\omega t$ .

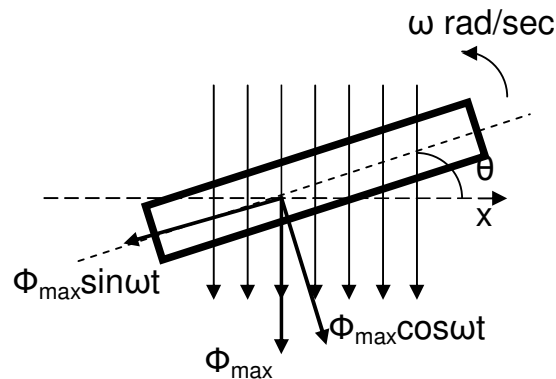

The component of flux acting along the plane of the coil does not induce any flux in the coil. Only the component acting perpendicular to the plane of the coil ie  $\Phi_{\max}\cos\omega t$  induces an emf in the coil.

$$\Phi = \Phi_{\max} \cos \omega t$$

$$e = -N \frac{d\Phi}{dt}$$

$$e = -N \frac{d}{dt} \Phi_{\max} \cos \omega t$$

$$e = N\Phi_{\max} \omega \sin \omega t$$

$$e = E_m \sin \omega t$$

Hence the emf induced in the coil is a sinusoidal emf. This will induce a sinusoidal current in the circuit given by

$$i = I_m \sin \omega t$$

## Angular Frequency ( $\omega$ )

Angular frequency is defined as the number of radians covered in one second (ie the angle covered by the rotating coil). The unit of angular frequency is rad/sec.

$$\omega = \frac{2\pi}{T} = 2\pi f$$

### Problem 1

An alternating current  $i$  is given by

$$i = 141.4 \sin 314t$$

Find i) The maximum value

ii) Frequency

iii) Time Period

iv) The instantaneous value when  $t=3\text{ms}$

$$i = 141.4 \sin 314t$$

$$i = I_m \sin \omega t$$

i) Maximum value  $I_m=141.4 \text{ V}$

ii)  $\omega = 314 \text{ rad/sec}$

$$f = \omega/2\pi = 50 \text{ Hz}$$

iii)  $T=1/f = 0.02 \text{ sec}$

iv)  $i=141.4 \sin(314 \times 0.003) = 114.35 \text{ A}$

## Average Value

The arithmetic average of all the values of an alternating quantity over one cycle is called its average value

Average value = Area under one cycle

Base

$$V_{av} = \frac{1}{2\pi} \int_0^{2\pi} v d(\omega t)$$

For Symmetrical waveforms, the average value calculated over one cycle becomes equal to zero because the positive area cancels the negative area. Hence for symmetrical waveforms, the average value is calculated for half cycle.

$$\text{Average value} = \frac{\text{Area under one half cycle}}{\text{Base}}$$

$$V_{av} = \frac{1}{\pi} \int_0^{\pi} v d(\omega t)$$

Average value of a sinusoidal current

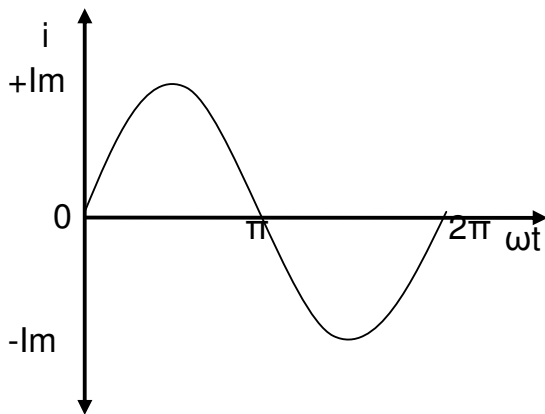

$$i = I_m \sin \omega t$$

$$I_{av} = \frac{1}{\pi} \int_0^{\pi} i d(\omega t)$$

$$I_{av} = \frac{1}{\pi} \int_0^{\pi} I_m \sin \omega t d(\omega t)$$

$$I_{av} = \frac{2I_m}{\pi} = 0.637I_m$$

Average value of a full wave rectifier output

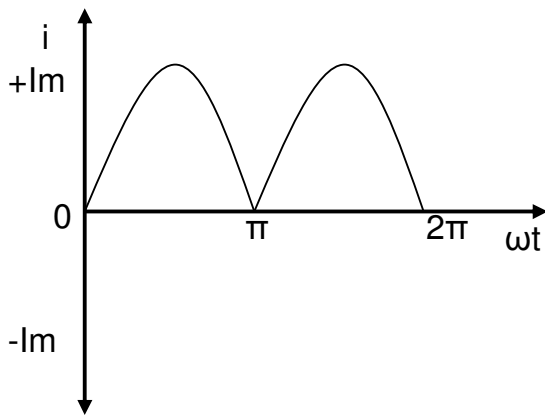

$$i = I_m \sin \omega t$$

$$I_{av} = \frac{1}{\pi} \int_0^{\pi} i d(\omega t)$$

$$I_{av} = \frac{1}{\pi} \int_0^{\pi} I_m \sin \omega t d(\omega t)$$

$$I_{av} = \frac{2I_m}{\pi} = 0.637I_m$$

Average value of a half wave rectifier output

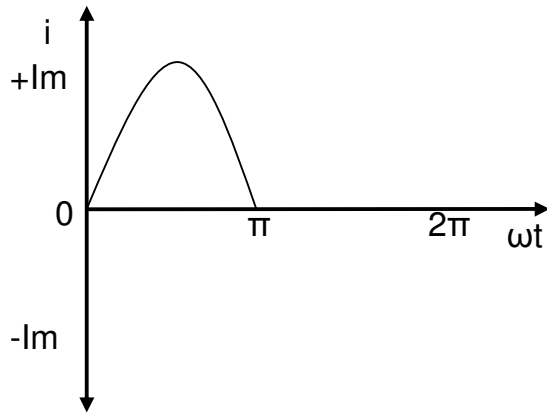

$$i = I_m \sin \omega t$$

$$I_{av} = \frac{1}{2\pi} \int_0^{2\pi} i d(\omega t)$$

$$I_{av} = \frac{1}{2\pi} \int_0^{\pi} I_m \sin \omega t d(\omega t)$$

$$I_{av} = \frac{I_m}{\pi} = 0.318 I_m$$

### RMS or Effective Value

The effective or RMS value of an alternating quantity is that steady current (dc) which when flowing through a given resistance for a given time produces the same amount of heat produced by the alternating current flowing through the same resistance for the same time.



$$RMS = \sqrt{\frac{\text{Area under squared curve}}{\text{base}}}$$

$$V_{rms} = \sqrt{\frac{1}{2\pi} \int_0^{2\pi} v^2 d(\omega t)}$$

RMS value of a sinusoidal current

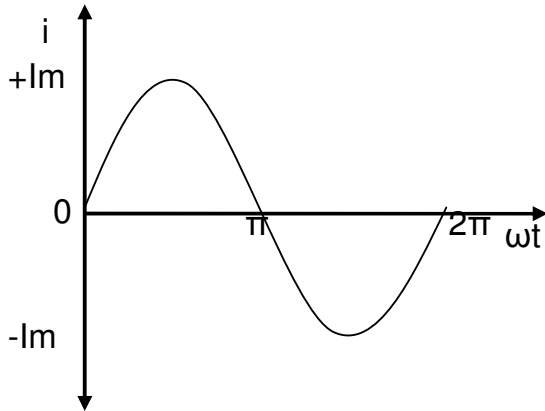

$$i = I_m \sin \omega t$$

$$I_{rms} = \sqrt{\frac{1}{2\pi} \int_0^{2\pi} i^2 d(\omega t)}$$

$$I_{rms} = \sqrt{\frac{1}{\pi} \int_0^{\pi} I_m^2 \sin^2 \omega t d(\omega t)}$$

$$I_{rms} = \frac{I_m}{\sqrt{2}} = 0.707 I_m$$

RMS value of a full wave rectifier output

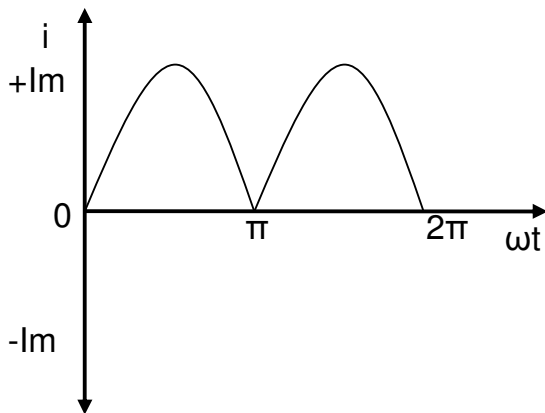

$$i = I_m \sin \omega t$$

$$I_{rms} = \sqrt{\frac{1}{2\pi} \int_0^{2\pi} i^2 d(\omega t)}$$

$$I_{rms} = \sqrt{\frac{1}{\pi} \int_0^{\pi} I_m^2 \sin^2 \omega t d(\omega t)}$$

$$I_{rms} = \frac{I_m}{\sqrt{2}} = 0.707 I_m$$

RMS value of a half wave rectifier output

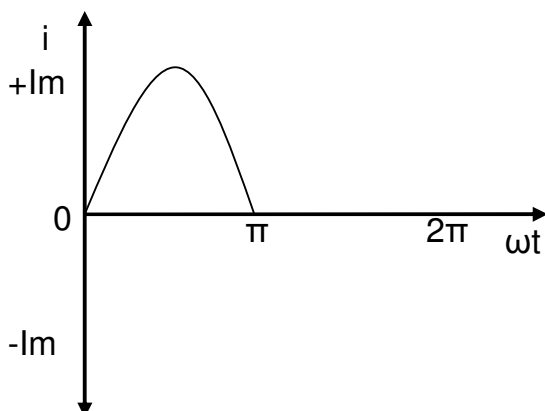

$$i = I_m \sin \omega t$$

$$I_{rms} = \sqrt{\frac{1}{2\pi} \int_0^{2\pi} i^2 d(\omega t)}$$

$$I_{rms} = \sqrt{\frac{1}{2\pi} \int_0^{\pi} I_m^2 \sin^2 \omega t d(\omega t)}$$

$$I_{rms} = \frac{I_m}{2} = 0.5 I_m$$

## Form Factor

The ratio of RMS value to the average value of an alternating quantity is known as Form Factor

$$FF = \frac{RMS\,Value}{Average\,Value}$$

## Peak Factor or Crest Factor

The ratio of maximum value to the RMS value of an alternating quantity is known as the peak factor

$$PF = \frac{Maximum\,Value}{RMS\,Value}$$

For a sinusoidal waveform

$$I_{av} = \frac{2I_m}{\pi} = 0.637I_m$$

$$I_{rms} = \frac{I_m}{\sqrt{2}} = 0.707I_m$$

$$FF = \frac{I_{rms}}{I_{av}} = \frac{0.707I_m}{0.637I_m} = 1.11$$

$$PF = \frac{I_m}{I_{rms}} = \frac{I_m}{0.707I_m} = 1.414$$

For a Full Wave Rectifier Output

$$I_{av} = \frac{2I_m}{\pi} = 0.637I_m$$

$$I_{rms} = \frac{I_m}{\sqrt{2}} = 0.707I_m$$

$$FF = \frac{I_{rms}}{I_{av}} = \frac{0.707I_m}{0.637I_m} = 1.11$$

$$PF = \frac{I_m}{I_{rms}} = \frac{I_m}{0.707I_m} = 1.414$$



For a Half Wave Rectifier Output

$$I_{av} = \frac{I_m}{\pi} = 0.318I_m$$

$$I_{rms} = \frac{I_m}{2} = 0.5I_m$$

$$FF = \frac{I_{rms}}{I_{av}} = \frac{0.5I_m}{0.318I_m} = 1.57$$

$$PF = \frac{I_m}{I_{rms}} = \frac{I_m}{0.5I_m} = 2$$

### Phasor Representation

An alternating quantity can be represented using

- (i) Waveform
- (ii) Equations
- (iii) Phasor

A sinusoidal alternating quantity can be represented by a rotating line called a **Phasor**. A phasor is a line of definite length rotating in anticlockwise direction at a constant angular velocity

The waveform and equation representation of an alternating current is as shown. This sinusoidal quantity can also be represented using phasors.

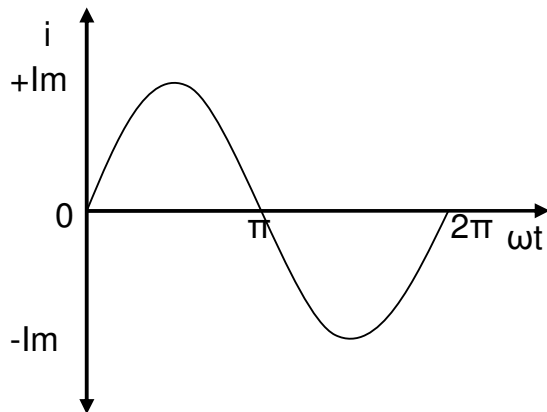

$$i = I_m \sin \omega t$$

Draw a line OP of length equal to  $I_m$ . This line OP rotates in the anticlockwise direction with a uniform angular velocity  $\omega$  rad/sec and follows the circular trajectory shown in figure. At any instant, the projection of OP on the y-axis is given by  $OM = OP \sin \theta = I_m \sin \omega t$ . Hence the line OP is the phasor representation of the sinusoidal current

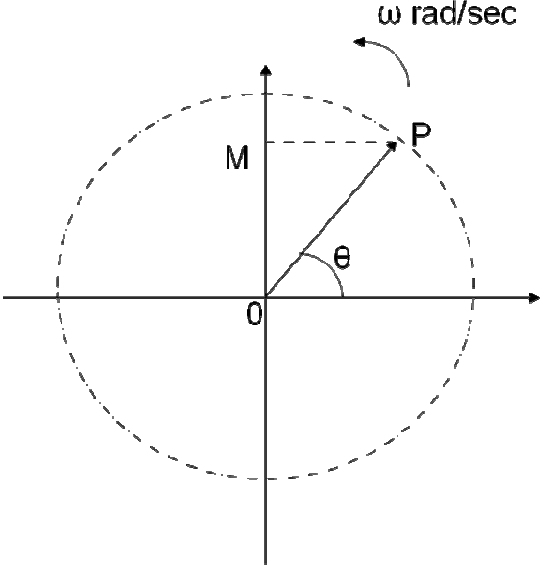

**Phase**

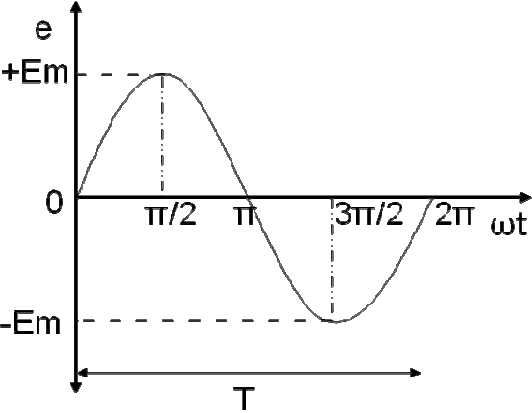

Phase is defined as the fractional part of time period or cycle through which the quantity has advanced from the selected zero position of reference

Phase of  $+E_m$  is  $\pi/2$  rad or  $T/4$  sec

Phase of  $-E_m$  is  $3\pi/2$  rad or  $3T/4$  sec

### Phase Difference

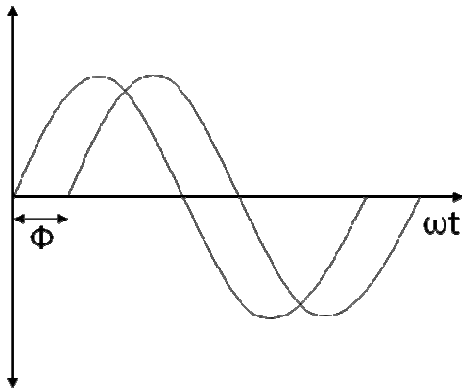

When two alternating quantities of the same frequency have different zero points, they are said to have a phase difference. The angle between the zero points is the angle of phase difference.

### In Phase

Two waveforms are said to be in phase, when the phase difference between them is zero. That is the zero points of both the waveforms are same. The waveform, phasor and equation representation of two sinusoidal quantities which are in phase is as shown. The figure shows that the voltage and current are in phase.

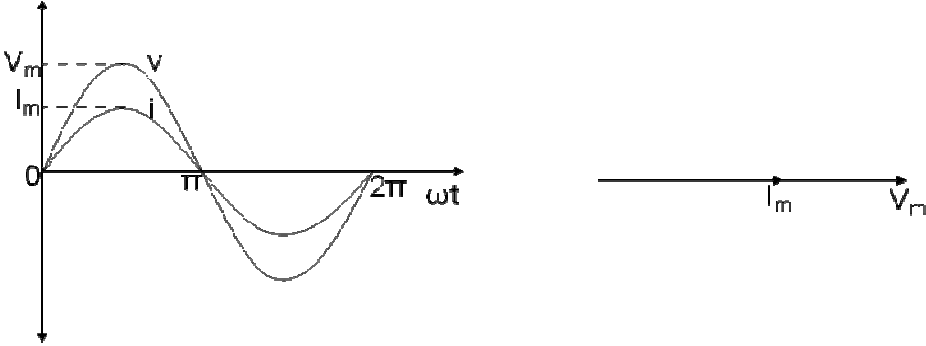

$$v = V_m \sin \omega t$$

$$i = I_m \sin \omega t$$

## Lagging

In the figure shown, the zero point of the current waveform is after the zero point of the voltage waveform. Hence the current is lagging behind the voltage. The waveform, phasor and equation representation is as shown.

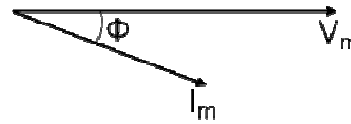
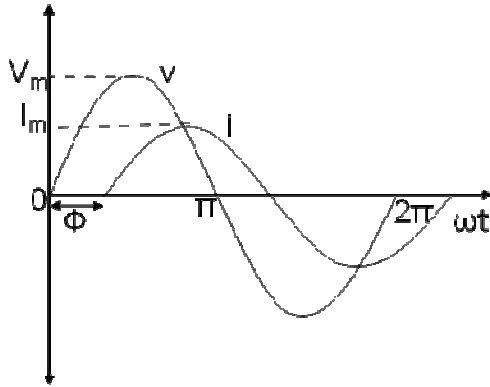

$$v = V_m \sin \omega t$$

$$i = I_m \sin(\omega t - \Phi)$$

## Leading

In the figure shown, the zero point of the current waveform is before the zero point of the voltage waveform. Hence the current is leading the voltage. The waveform, phasor and equation representation is as shown.

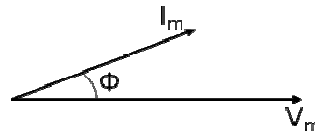
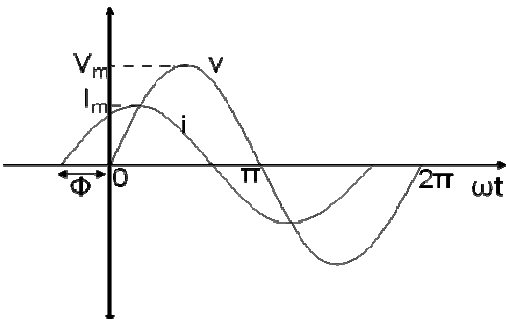

$$v = V_m \sin \omega t$$

$$i = I_m \sin(\omega t + \Phi)$$

## AC circuit with a pure resistance

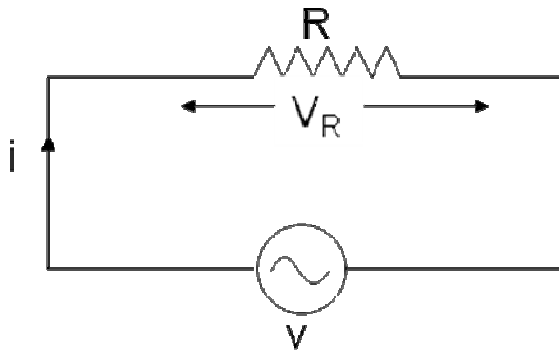

Consider an AC circuit with a pure resistance  $R$  as shown in the figure. The alternating voltage  $v$  is given by

$$v = V_m \sin \omega t \quad \text{----- (1)}$$

The current flowing in the circuit is  $i$ . The voltage across the resistor is given as  $V_R$  which is the same as  $v$ .

Using ohms law, we can write the following relations

$$i = \frac{v}{R} = \frac{V_m \sin \omega t}{R}$$

$$i = I_m \sin \omega t \quad \text{-----(2)}$$

Where  $I_m = \frac{V_m}{R}$

From equation (1) and (2) we conclude that in a pure resistive circuit, the voltage and current are in phase. Hence the voltage and current waveforms and phasors can be drawn as below.

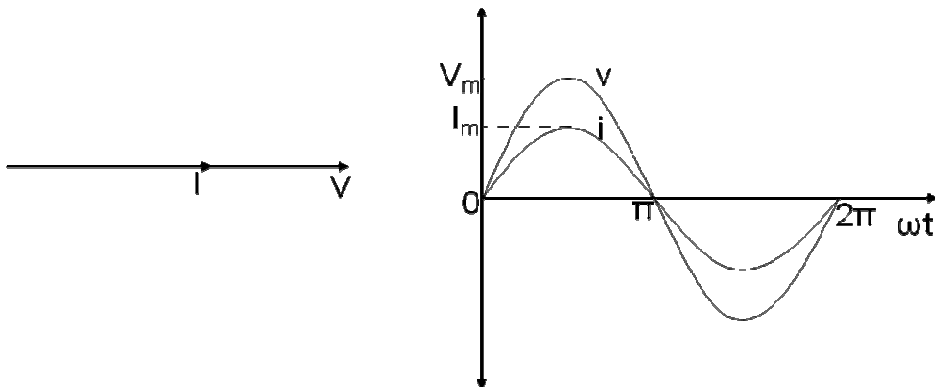

## Instantaneous power

The instantaneous power in the above circuit can be derived as follows

$$\begin{aligned}p &= vi \\p &= (V_m \sin \omega t)(I_m \sin \omega t) \\p &= V_m I_m \sin^2 \omega t \\p &= \frac{V_m I_m}{2} (1 - \cos 2\omega t) \\p &= \frac{V_m I_m}{2} - \frac{V_m I_m}{2} \cos 2\omega t\end{aligned}$$

The instantaneous power consists of two terms. The first term is called as the constant power term and the second term is called as the fluctuating power term.

## Average power

From the instantaneous power we can find the average power over one cycle as follows

$$\begin{aligned}P &= \frac{1}{2\pi} \int_0^{2\pi} \left[ \frac{V_m I_m}{2} - \frac{V_m I_m}{2} \cos 2\omega t \right] d\omega t \\P &= \frac{V_m I_m}{2} - \frac{1}{2\pi} \int_0^{2\pi} \left[ \frac{V_m I_m}{2} \cos 2\omega t \right] d\omega t \\P &= \frac{V_m I_m}{2} = \frac{V_m}{\sqrt{2}} \frac{I_m}{\sqrt{2}} \\P &= V.I\end{aligned}$$

As seen above the average power is the product of the rms voltage and the rms current.

The voltage, current and power waveforms of a purely resistive circuit is as shown in the figure.

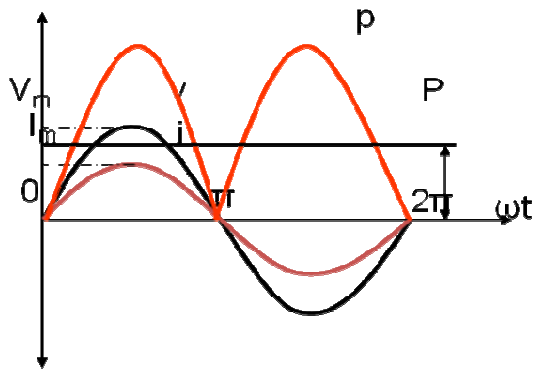

As seen from the waveform, the instantaneous power is always positive meaning that the power always flows from the source to the load.

Phasor Algebra for a pure resistive circuit

$$\bar{V} = V\angle 0^\circ = V + j0$$

$$\bar{I} = \frac{\bar{V}}{R} = \frac{V + j0}{R} = I + j0 = I\angle 0^\circ$$

Problem 2

An ac circuit consists of a pure resistance of  $10\Omega$  and is connected to an ac supply of 230 V, 50 Hz. Calculate the (i) current (ii) power consumed and (iii) equations for voltage and current.

$$(i) I = \frac{V}{R} = \frac{230}{10} = 23A$$

$$(ii) P = VI = 230 \times 23 = 5260W$$

$$(iii) V_m = \sqrt{2}V = 325.27V$$

$$I_m = \sqrt{2}I = 32.52A$$

$$\omega = 2\pi f = 314 \text{ rad / sec}$$

$$v = 325.25 \sin 314t$$

$$i = 32.52 \sin 314t$$

## AC circuit with a pure inductance

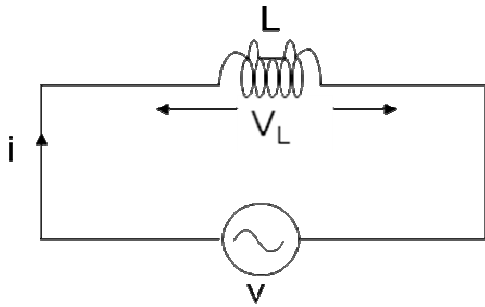

Consider an AC circuit with a pure inductance  $L$  as shown in the figure. The alternating voltage  $v$  is given by

$$v = V_m \sin \omega t \quad \text{----- (1)}$$

The current flowing in the circuit is  $i$ . The voltage across the inductor is given as  $V_L$  which is the same as  $v$ .

We can find the current through the inductor as follows

$$v = L \frac{di}{dt}$$

$$V_m \sin \omega t = L \frac{di}{dt}$$

$$di = \frac{V_m}{L} \sin \omega t dt$$

$$i = \frac{V_m}{L} \int \sin \omega t dt$$

$$i = \frac{V_m}{\omega L} (-\cos \omega t)$$

$$i = \frac{V_m}{\omega L} \sin(\omega t - \pi / 2)$$

$$i = I_m \sin(\omega t - \pi / 2) \quad \text{-----(2)}$$

Where  $I_m = \frac{V_m}{\omega L}$



From equation (1) and (2) we observe that in a pure inductive circuit, the current lags behind the voltage by  $90^\circ$ . Hence the voltage and current waveforms and phasors can be drawn as below.

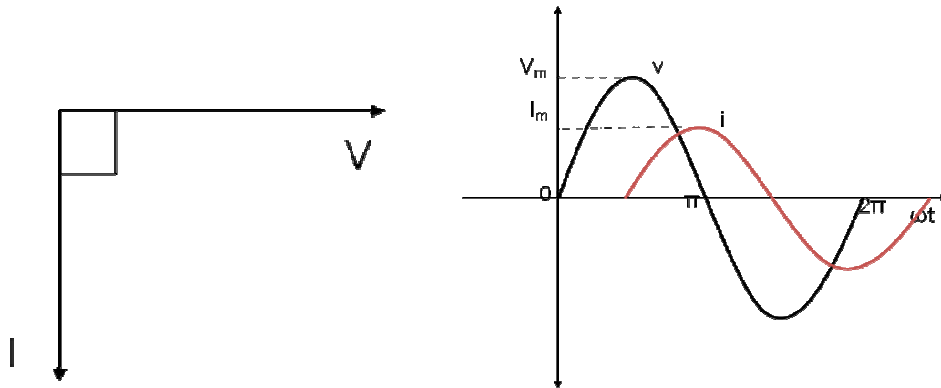

### Inductive reactance

The inductive reactance  $X_L$  is given as

$$X_L = \omega L = 2\pi fL$$

$$I_m = \frac{V_m}{X_L}$$

It is equivalent to resistance in a resistive circuit. The unit is ohms ( $\Omega$ )

### Instantaneous power

The instantaneous power in the above circuit can be derived as follows

$$p = vi$$

$$p = (V_m \sin \omega t)(I_m \sin(\omega t - \pi / 2))$$

$$p = -V_m I_m \sin \omega t \cos \omega t$$

$$p = -\frac{V_m I_m}{2} \sin 2\omega t$$

As seen from the above equation, the instantaneous power is fluctuating in nature.

## Average power

From the instantaneous power we can find the average power over one cycle as follows

$$P = \frac{1}{2\pi} \int_0^{2\pi} -\frac{V_m I_m}{2} \sin 2\omega t d\omega t$$
$$P = 0$$

The average power in a pure inductive circuit is zero. Or in other words, the power consumed by a pure inductance is zero.

The voltage, current and power waveforms of a purely inductive circuit is as shown in the figure.

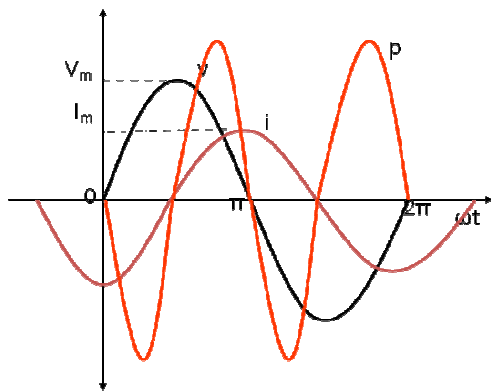

As seen from the power waveform, the instantaneous power is alternately positive and negative. When the power is positive, the power flows from the source to the inductor and when the power is negative, the power flows from the inductor to the source. The positive power is equal to the negative power and hence the average power in the circuit is equal to zero. The power just flows between the source and the inductor, but the inductor does not consume any power.

## Phasor algebra for a pure inductive circuit

$$\bar{V} = V\angle 0^\circ = V + j0$$

$$\bar{I} = I\angle -90^\circ = 0 - jI$$

$$\frac{\bar{V}}{\bar{I}} = \frac{V\angle 0^\circ}{I\angle -90^\circ} = X_L\angle 90^\circ$$

$$\bar{V} = \bar{I}(jX_L)$$

### Problem 3

A pure inductive coil allows a current of 10A to flow from a 230V, 50 Hz supply. Find (i) inductance of the coil (ii) power absorbed and (iii) equations for voltage and current.

$$(i) X_L = \frac{V}{I} = \frac{230}{10} = 23\Omega$$

$$X_L = 2\pi fL$$

$$L = \frac{X_L}{2\pi f} = 0.073H$$

$$(ii) P = 0$$

$$(iii) V_m = \sqrt{2}V = 325.27V$$

$$I_m = \sqrt{2}I = 14.14A$$

$$\omega = 2\pi f = 314 \text{ rad / sec}$$

$$v = 325.25 \sin 314t$$

$$i = 14.14 \sin(314t - \pi / 2)$$

### AC circuit with a pure capacitance

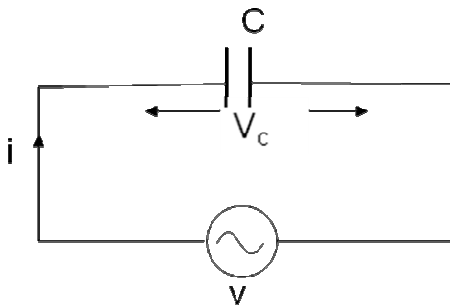

Consider an AC circuit with a pure capacitance  $C$  as shown in the figure. The alternating voltage  $v$  is given by

$$v = V_m \sin \omega t \quad \text{----- (1)}$$

The current flowing in the circuit is  $i$ . The voltage across the capacitor is given as  $V_C$  which is the same as  $v$ .

We can find the current through the capacitor as follows

$$q = Cv$$

$$q = CV_m \sin \omega t$$

$$i = \frac{dq}{dt}$$

$$i = CV_m \omega \cos \omega t$$

$$i = \omega CV_m \sin(\omega t + \pi / 2)$$

$$i = I_m \sin(\omega t + \pi / 2) \quad \text{-----(2)}$$

Where  $I_m = \omega CV_m$

From equation (1) and (2) we observe that in a pure capacitive circuit, the current leads the voltage by  $90^\circ$ . Hence the voltage and current waveforms and phasors can be drawn as below.

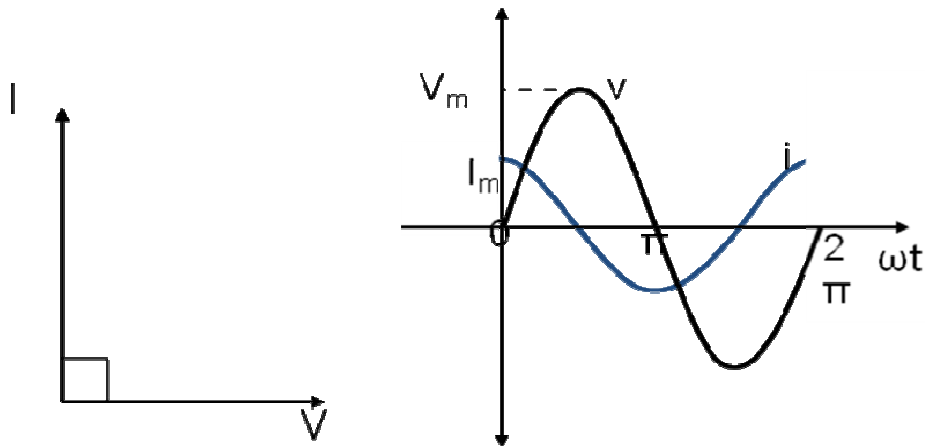

## Capacitive reactance

The capacitive reactance  $X_C$  is given as

$$X_L = \frac{1}{\omega C} = \frac{1}{2\pi f C}$$

$$I_m = \frac{V_m}{X_C}$$

It is equivalent to resistance in a resistive circuit. The unit is ohms ( $\Omega$ )

## Instantaneous power

The instantaneous power in the above circuit can be derived as follows

$$p = vi$$

$$p = (V_m \sin \omega t)(I_m \sin(\omega t + \pi / 2))$$

$$p = V_m I_m \sin \omega t \cos \omega t$$

$$p = \frac{V_m I_m}{2} \sin 2\omega t$$

As seen from the above equation, the instantaneous power is fluctuating in nature.

## Average power

From the instantaneous power we can find the average power over one cycle as follows

$$P = \frac{1}{2\pi} \int_0^{2\pi} \frac{V_m I_m}{2} \sin 2\omega t d\omega t$$

$$P = 0$$

The average power in a pure capacitive circuit is zero. Or in other words, the power consumed by a pure capacitance is zero.

The voltage, current and power waveforms of a purely capacitive circuit is as shown in the figure.

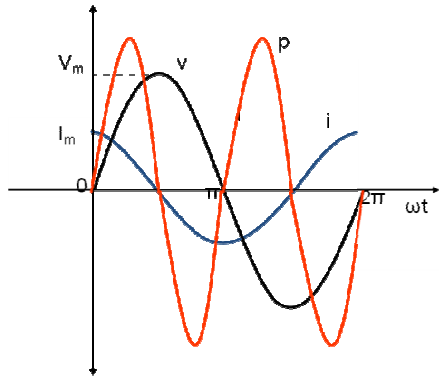

As seen from the power waveform, the instantaneous power is alternately positive and negative. When the power is positive, the power flows from the source to the capacitor and when the power is negative, the power flows from the capacitor to the source. The positive power is equal to the negative power and hence the average power in the circuit is equal to zero. The power just flows between the source and the capacitor, but the capacitor does not consume any power.

Phasor algebra in a pure capacitive circuit

$$\bar{V} = V \angle 0^\circ = V + j0$$

$$\bar{I} = I \angle 90^\circ = 0 + jI$$

$$\frac{\bar{V}}{\bar{I}} = \frac{V \angle 0^\circ}{I \angle 90^\circ} = X_C \angle -90^\circ$$

$$\bar{V} = \bar{I}(-jX_C)$$

Problem 4

A  $318\mu\text{F}$  capacitor is connected across a 230V, 50 Hz system. Find (i) the capacitive reactance (ii) rms value of current and (iii) equations for voltage and current.

$$(i) X_C = \frac{1}{2\pi f C} = 10\Omega$$

$$(ii) I = \frac{V}{X_C} = 23A$$

$$(iii) V_m = \sqrt{2}V = 325.27V$$

$$I_m = \sqrt{2}I = 32.53A$$

$$\omega = 2\pi f = 314 \text{ rad / sec}$$

$$v = 325.25 \sin 314t$$

$$i = 32.53 \sin(314t + \pi / 2)$$

### R-L Series circuit

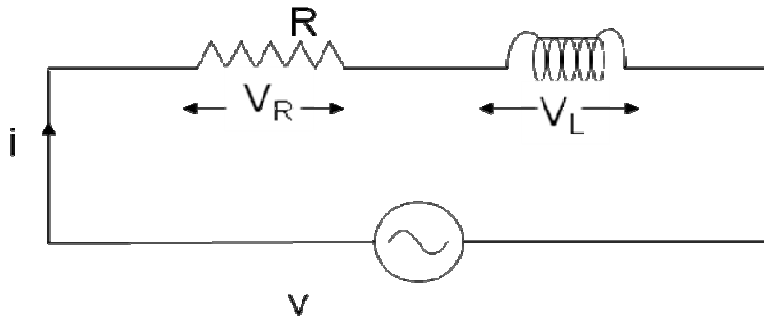

Consider an AC circuit with a resistance  $R$  and an inductance  $L$  connected in series as shown in the figure. The alternating voltage  $v$  is given by

$$v = V_m \sin \omega t$$

The current flowing in the circuit is  $i$ . The voltage across the resistor is  $V_R$  and that across the inductor is  $V_L$ .

$V_R = IR$  is in phase with  $I$

$V_L = IX_L$  leads current by 90 degrees

With the above information, the phasor diagram can be drawn as shown.

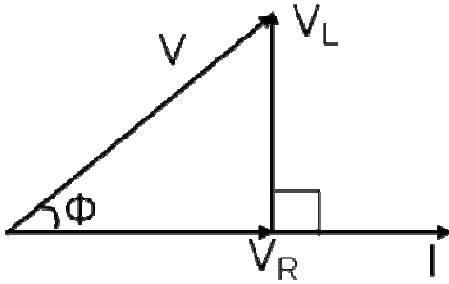

The current  $I$  is taken as the reference phasor. The voltage  $V_R$  is in phase with  $I$  and the voltage  $V_L$  leads the current by  $90^\circ$ . The resultant voltage  $V$  can be drawn as shown in the figure. From the phasor diagram we observe that the voltage leads the current by an angle  $\Phi$  or in other words the current lags behind the voltage by an angle  $\Phi$ .

The waveform and equations for an RL series circuit can be drawn as below.

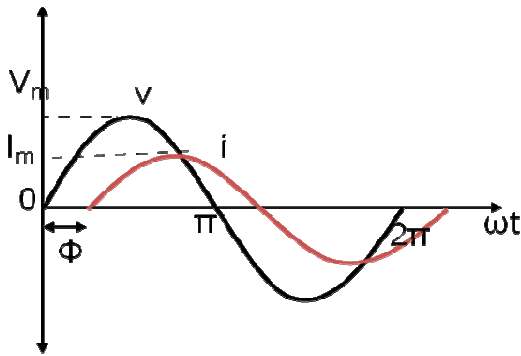

$$V = V_m \sin \omega t$$

$$I = I_m \sin(\omega t - \Phi)$$

From the phasor diagram, the expressions for the resultant voltage  $V$  and the angle  $\Phi$  can be derived as follows.

$$V = \sqrt{V_R^2 + V_L^2}$$

$$V_R = IR$$

$$V_L = IX_L$$

$$V = \sqrt{(IR)^2 + (IX_L)^2}$$

$$V = I\sqrt{R^2 + X_L^2}$$

$$V = IZ$$

Where impedance  $Z = \sqrt{R^2 + X_L^2}$

The impedance in an AC circuit is similar to a resistance in a DC circuit. The unit for impedance is ohms ( $\Omega$ ).



Phase angle

$$\Phi = \tan^{-1}\left(\frac{V_L}{V_R}\right)$$

$$\Phi = \tan^{-1}\left(\frac{IX_L}{IR}\right)$$

$$\Phi = \tan^{-1}\left(\frac{X_L}{R}\right)$$

$$\Phi = \tan^{-1}\left(\frac{\omega L}{R}\right)$$

Instantaneous power

The instantaneous power in an RL series circuit can be derived as follows

$$p = vi$$

$$p = (V_m \sin \omega t)(I_m \sin(\omega t - \Phi))$$

$$p = \frac{V_m I_m}{2} \cos \Phi - \frac{V_m I_m}{2} \cos(2\omega t - \Phi)$$

The instantaneous power consists of two terms. The first term is called as the constant power term and the second term is called as the fluctuating power term.

Average power

From the instantaneous power we can find the average power over one cycle as follows

$$P = \frac{1}{2\pi} \int_0^{2\pi} \left[ \frac{V_m I_m}{2} \cos \Phi - \frac{V_m I_m}{2} \cos(2\omega t - \Phi) \right] d\omega t$$

$$P = \frac{V_m I_m}{2} \cos \Phi$$

$$P = \frac{V_m}{\sqrt{2}} \frac{I_m}{\sqrt{2}} \cos \Phi$$

$$P = VI \cos \Phi$$

The voltage, current and power waveforms of a RL series circuit is as shown in the figure.

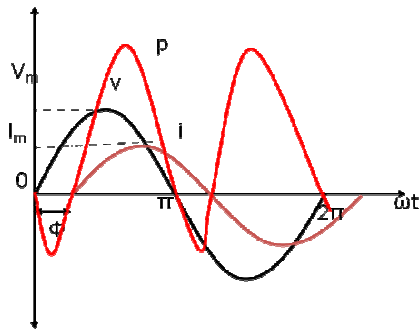

As seen from the power waveform, the instantaneous power is alternately positive and negative. When the power is positive, the power flows from the source to the load and when the power is negative, the power flows from the load to the source. The positive power is not equal to the negative power and hence the average power in the circuit is not equal to zero.

From the phasor diagram,

$$\cos \Phi = \frac{V_R}{V} = \frac{IR}{IZ} = \frac{R}{Z}$$

$$P = VI \cos \Phi$$

$$P = (IZ) \times I \times \frac{R}{Z}$$

$$P = I^2 R$$

Hence the power in an RL series circuit is consumed only in the resistance. The inductance does not consume any power.

### Power Factor

The power factor in an AC circuit is defined as the cosine of the angle between voltage and current ie  $\cos \Phi$

$$P = VI \cos \Phi$$

The power in an AC circuit is equal to the product of voltage, current and power factor.

### Impedance Triangle

We can derive a triangle called the impedance triangle from the phasor diagram of an RL series circuit as shown

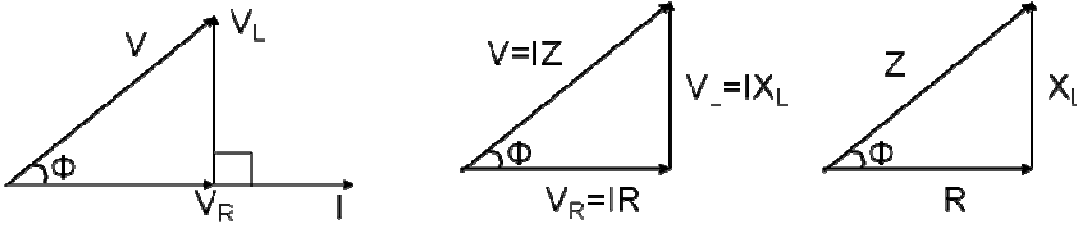

The impedance triangle is right angled triangle with  $R$  and  $X_L$  as two sides and impedance as the hypotenuse. The angle between the base and hypotenuse is  $\Phi$ . The impedance triangle enables us to calculate the following things.

1. Impedance  $Z = \sqrt{R^2 + X_L^2}$
2. Power Factor  $\cos \Phi = \frac{R}{Z}$
3. Phase angle  $\Phi = \tan^{-1}\left(\frac{X_L}{R}\right)$
4. Whether current leads or lags behind the voltage

## Power

In an AC circuit, the various powers can be classified as

1. Real or Active power
2. Reactive power
3. Apparent power

Real or active power in an AC circuit is the power that does useful work in the circuit. Reactive power flows in an AC circuit but does not do any useful work. Apparent power is the total power in an AC circuit.

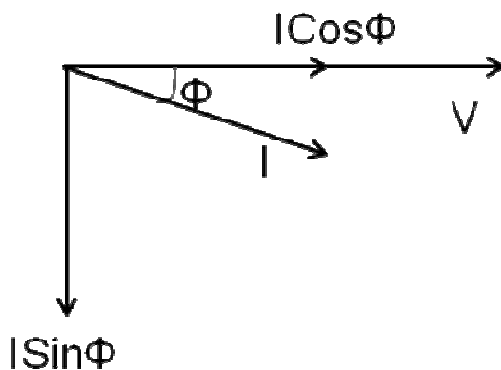

From the phasor diagram of an RL series circuit, the current can be divided into two components. One component along the voltage  $I\cos\Phi$ , that is called as the active component of current and another component perpendicular to the voltage  $I\sin\Phi$  that is called as the reactive component of current.

### Real Power

The power due to the active component of current is called as the active power or real power. It is denoted by P.

$$P = V \times I \cos\Phi = I^2 R$$

Real power is the power that does useful power. It is the power that is consumed by the resistance.

The unit for real power in Watt(W).

### Reactive Power

The power due to the reactive component of current is called as the reactive power. It is denoted by Q.

$$Q = V \times I \sin\Phi = I^2 X_L$$

Reactive power does not do any useful work. It is the circulating power in th L and C components.

The unit for reactive power is Volt Amperes Reactive (VAR).

### Apparent Power

The apparent power is the total power in the circuit. It is denoted by S.

$$S = V \times I = I^2 Z$$

$$S = \sqrt{P^2 + Q^2}$$

The unit for apparent power is Volt Amperes (VA).

### Power Triangle

From the impedance triangle, another triangle called the power triangle can be derived as shown.

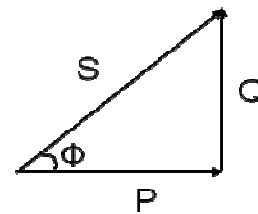
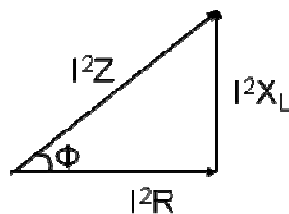
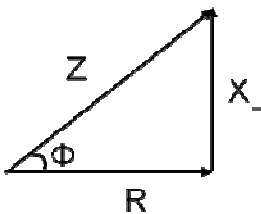

The power triangle is right angled triangle with P and Q as two sides and S as the hypotenuse. The angle between the base and hypotenuse is  $\Phi$ . The power triangle enables us to calculate the following things.

$$1. \text{ Apparent power } S = \sqrt{P^2 + Q^2}$$

$$2. \text{ Power Factor } \cos\Phi = \frac{P}{S} = \frac{\text{RealPower}}{\text{ApparentPower}}$$

The power Factor in an AC circuit can be calculated by any one of the following methods

- ❖ Cosine of angle between V and I
- ❖ Resistance/Impedance  $R/Z$
- ❖ Real Power/Apparent Power  $P/S$

Phasor algebra in a RL series circuit

$$\bar{V} = V + j0 = V\angle 0^\circ$$

$$\bar{Z} = R + jX_L = Z\angle\Phi$$

$$\bar{I} = \frac{\bar{V}}{\bar{Z}} = \frac{V}{Z}\angle -\Phi$$

$$\bar{S} = \bar{V}\bar{I}^* = P + jQ$$

### Problem 5

A coil having a resistance of  $7\Omega$  and an inductance of  $31.8\text{mH}$  is connected to  $230\text{V}$ ,  $50\text{Hz}$  supply.

Calculate (i) the circuit current (ii) phase angle (iii) power factor (iv) power consumed

$$X_L = 2\pi fL = 2 \times 3.14 \times 50 \times 31.8 \times 10^{-3} = 10\Omega$$

$$Z = \sqrt{R^2 + X_L^2} = \sqrt{7^2 + 10^2} = 12.2\Omega$$

$$(i) I = \frac{V}{Z} = \frac{230}{12.2} = 18.85A$$

$$(ii) \phi = \tan^{-1}\left(\frac{X_L}{R}\right) = \tan^{-1}\left(\frac{10}{7}\right) = 55^\circ \text{ lag}$$

$$(iii) PF = \cos \Phi = \cos(55^\circ) = 0.573 \text{ lag}$$

$$(iv) P = VI \cos \Phi = 230 \times 18.85 \times 0.573 = 2484.24W$$

### Problem 6

A 200 V, 50 Hz, inductive circuit takes a current of 10A, lagging 30 degree. Find (i) the resistance

(ii) reactance (iii) inductance of the coil

$$Z = \frac{V}{I} = \frac{200}{10} = 20\Omega$$

$$(i) R = Z \cos \phi = 20 \times \cos 30^\circ = 17.32\Omega$$

$$(ii) X_L = Z \sin \phi = 20 \times \sin 30^\circ = 10\Omega$$

$$(iii) L = \frac{X_L}{2\pi f} = \frac{10}{2 \times 3.14 \times 50} = 0.0318H$$

### R-C Series circuit

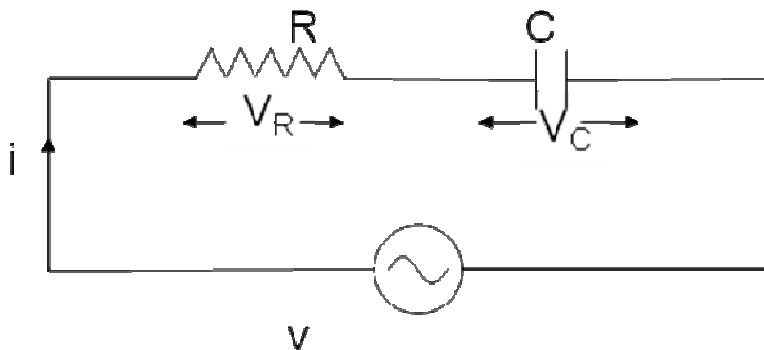

Consider an AC circuit with a resistance R and a capacitance C connected in series as shown in the figure. The alternating voltage v is given by

$$v = V_m \sin \omega t$$

The current flowing in the circuit is i. The voltage across the resistor is  $V_R$  and that across the capacitor is  $V_C$ .

$V_R = IR$  is in phase with I

$V_C = IX_C$  lags behind the current by 90 degrees

With the above information, the phasor diagram can be drawn as shown.

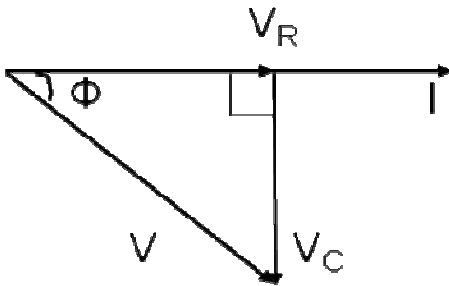

The current I is taken as the reference phasor. The voltage  $V_R$  is in phase with I and the voltage  $V_C$  lags behind the current by  $90^\circ$ . The resultant voltage V can be drawn as shown in the figure. From the phasor diagram we observe that the voltage lags behind the current by an angle  $\Phi$  or in other words the current leads the voltage by an angle  $\Phi$ .

The waveform and equations for an RC series circuit can be drawn as below.

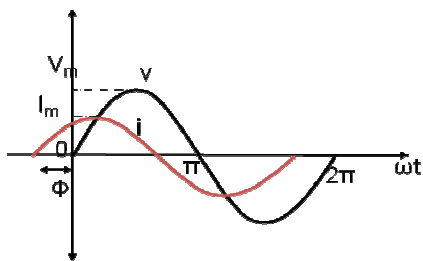

$$V = V_m \sin \omega t$$

$$I = I_m \sin(\omega t + \Phi)$$

From the phasor diagram, the expressions for the resultant voltage V and the angle  $\Phi$  can be derived as follows.

$$V = \sqrt{V_R^2 + V_C^2}$$

$$V_R = IR$$

$$V_C = IX_C$$

$$V = \sqrt{(IR)^2 + (IX_C)^2}$$

$$V = I\sqrt{R^2 + X_C^2}$$

$$V = IZ$$

Where impedance  $Z = \sqrt{R^2 + X_C^2}$

Phase angle

$$\Phi = \tan^{-1}\left(\frac{V_C}{V_R}\right)$$

$$\Phi = \tan^{-1}\left(\frac{IX_C}{IR}\right)$$

$$\Phi = \tan^{-1}\left(\frac{X_C}{R}\right)$$

$$\Phi = \tan^{-1}\left(\frac{1}{\omega CR}\right)$$

Average power

$$P = VI \cos \phi$$

$$P = (IZ) \times I \times \frac{R}{Z}$$

$$P = I^2 R$$

Hence the power in an RC series circuit is consumed only in the resistance. The capacitance does not consume any power.



## Impedance Triangle

We can derive a triangle called the impedance triangle from the phasor diagram of an RC series circuit as shown

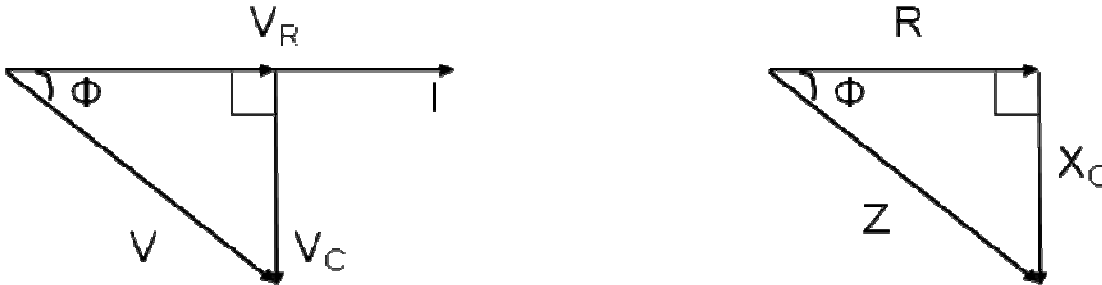

Phasor algebra for RC series circuit

$$V = V + j0 = V \angle 0^\circ$$

$$\bar{Z} = R - jX_C = Z \angle -\Phi$$

$$\bar{I} = \frac{\bar{V}}{\bar{Z}} = \frac{V}{Z} \angle +\Phi$$

### Problem 7

A Capacitor of capacitance  $79.5\mu\text{F}$  is connected in series with a non inductive resistance of  $30\Omega$  across a  $100\text{V}$ ,  $50\text{Hz}$  supply. Find (i) impedance (ii) current (iii) phase angle (iv) Equation for the instantaneous value of current

$$X_C = \frac{1}{2\pi f C} = \frac{1}{2 \times 3.14 \times 50 \times 79.5 \times 10^{-6}} = 40\Omega$$

$$(i) Z = \sqrt{R^2 + X_C^2} = \sqrt{30^2 + 40^2} = 50\Omega$$

$$(ii) I = \frac{V}{Z} = \frac{100}{50} = 2\text{A}$$

$$(iii) \Phi = \tan^{-1}\left(\frac{X_C}{R}\right) = \tan^{-1}\left(\frac{40}{30}\right) = 53^\circ \text{ lead}$$

$$(iv) I_m = \sqrt{2}I = \sqrt{2} \times 2 = 2.828\text{A}$$

$$\omega = 2\pi f = 2 \times 3.14 \times 50 = 314 \text{ rad / sec}$$

$$i = 2.828 \sin(314t + 53^\circ)$$

## R-L-C Series circuit

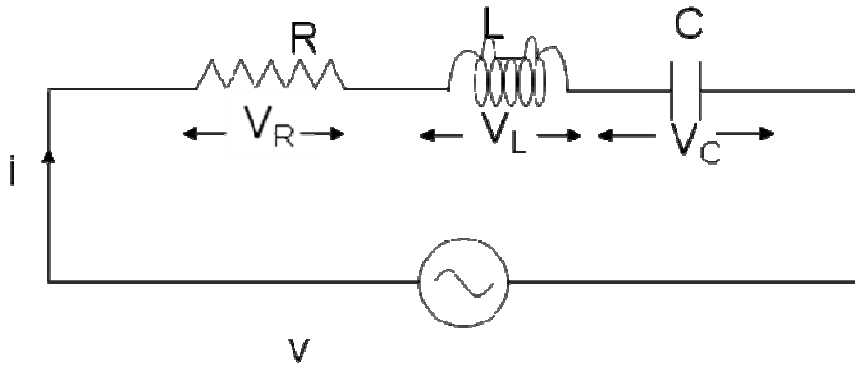

Consider an AC circuit with a resistance  $R$ , an inductance  $L$  and a capacitance  $C$  connected in series as shown in the figure. The alternating voltage  $v$  is given by

$$v = V_m \sin \omega t$$

The current flowing in the circuit is  $i$ . The voltage across the resistor is  $V_R$ , the voltage across the inductor is  $V_L$  and that across the capacitor is  $V_C$ .

$V_R = IR$  is in phase with  $I$

$V_L = IX_L$  leads the current by 90 degrees

$V_C = IX_C$  lags behind the current by 90 degrees

With the above information, the phasor diagram can be drawn as shown. The current  $I$  is taken as the reference phasor. The voltage  $V_R$  is in phase with  $I$ , the voltage  $V_L$  leads the current by  $90^\circ$  and the voltage  $V_C$  lags behind the current by  $90^\circ$ . There are two cases that can occur  $V_L > V_C$  and  $V_L < V_C$  depending on the values of  $X_L$  and  $X_C$ . And hence there are two possible phasor diagrams. The phasor  $V_L - V_C$  or  $V_C - V_L$  is drawn and then the resultant voltage  $V$  is drawn.

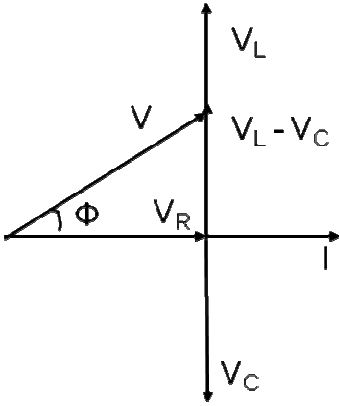

$$V_L > V_C$$

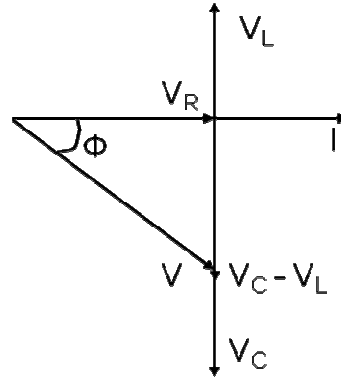

$$V_L < V_C$$

From the phasor diagram we observe that when  $V_L > V_C$ , the voltage leads the current by an angle  $\Phi$  or in other words the current lags behind the voltage by an angle  $\Phi$ . When  $V_L < V_C$ , the voltage lags behind the current by an angle  $\Phi$  or in other words the current leads the voltage by an angle  $\Phi$ .

From the phasor diagram, the expressions for the resultant voltage  $V$  and the angle  $\Phi$  can be derived as follows.

$$V = \sqrt{V_R^2 + (V_L - V_C)^2}$$

$$V = \sqrt{(IR)^2 + (IX_L - IX_C)^2}$$

$$V = I\sqrt{R^2 + (X_L - X_C)^2}$$

$$V = IZ$$

Where impedance  $Z = \sqrt{R^2 + (X_L - X_C)^2}$

Phase angle

$$\Phi = \tan^{-1}\left(\frac{V_L - V_C}{V_R}\right)$$

$$\Phi = \tan^{-1}\left(\frac{IX_L - IX_C}{IR}\right)$$

$$\Phi = \tan^{-1}\left(\frac{X_L - X_C}{R}\right)$$

From the expression for phase angle, we can derive the following three cases

Case (i): When  $X_L > X_C$

The phase angle  $\Phi$  is positive and the circuit is inductive. The circuit behaves like a series RL circuit.

Case (ii): When  $X_L < X_C$

The phase angle  $\Phi$  is negative and the circuit is capacitive. The circuit behaves like a series RC circuit.

Case (iii): When  $X_L = X_C$

The phase angle  $\Phi = 0$  and the circuit is purely resistive. The circuit behaves like a pure resistive circuit.

The voltage and the current can be represented by the following equations. The angle  $\Phi$  is positive or negative depending on the circuit elements.

$$V = V_m \sin \omega t$$

$$I = I_m \sin(\omega t \pm \Phi)$$

Average power

$$P = VI \cos \phi$$

$$P = (IZ) \times I \times \frac{R}{Z}$$

$$P = I^2 R$$

Hence the power in an RLC series circuit is consumed only in the resistance. The inductance and the capacitance do not consume any power.

Phasor algebra for RLC series circuit

$$\bar{V} = V + j0 = V \angle 0^\circ$$

$$\bar{Z} = R + j(X_L - X_C) = Z \angle \Phi$$

$$\bar{I} = \frac{\bar{V}}{\bar{Z}} = \frac{V}{Z} \angle -\Phi$$

### Problem 8

A 230 V, 50 Hz ac supply is applied to a coil of 0.06 H inductance and 2.5  $\Omega$  resistance connected in series with a 6.8  $\mu\text{F}$  capacitor. Calculate (i) Impedance (ii) Current (iii) Phase angle between current and voltage (iv) power factor (v) power consumed

$$X_L = 2\pi fL = 2 \times 3.14 \times 50 \times 0.06 = 18.84 \Omega$$

$$X_C = \frac{1}{2\pi fC} = \frac{1}{2 \times 3.14 \times 50 \times 6.8 \times 10^{-6}} = 468 \Omega$$

$$(i) Z = \sqrt{R^2 + (X_L - X_C)^2} = \sqrt{2.5^2 + (18.84 - 468)^2} = 449.2 \Omega$$

$$(ii) I = \frac{V}{Z} = \frac{230}{449.2} = 0.512 \text{ A}$$

$$(iii) \Phi = \tan^{-1}\left(\frac{X_L - X_C}{R}\right) = \tan^{-1}\left(\frac{18.84 - 468}{2.5}\right) = -89.7^\circ$$

$$(iv) pf = \cos \Phi = \cos 89.7 = 0.0056 \text{ lead}$$

$$(v) P = VI \cos \Phi = 230 \times 0.512 \times 0.0056 = 0.66 \text{ W}$$

### Problem 9

A resistance R, an inductance L=0.01 H and a capacitance C are connected in series. When an alternating voltage  $v=400\sin(3000t-20^\circ)$  is applied to the series combination, the current flowing is  $10\sqrt{2}\sin(3000t-65^\circ)$ . Find the values of R and C.

$$\Phi = 65^\circ - 20^\circ = 45^\circ \text{ lag}$$

$$X_L = \omega L = 3000 \times 0.01 = 30 \Omega$$

$$\tan \Phi = \tan 45^\circ = 1$$

$$\tan \Phi = \frac{X_L - X_C}{R} = 1$$

$$R = X_L - X_C$$

$$Z = \frac{V_m}{I_m} = \frac{400}{10\sqrt{2}} = 28.3 \Omega Z = \sqrt{R^2 + (X_L - X_C)^2} = \sqrt{R^2 + R^2}$$

$$\sqrt{2}R = 28.3$$

$$R = 20 \Omega$$

$$X_L - X_C = 20 \Omega$$

$$X_C = 30 - 20 = 10 \Omega$$

$$C = \frac{1}{\omega X_C} = \frac{1}{3000 \times 10} = 33.3 \mu\text{F}$$

### Problem 10

A coil of pf 0.6 is in series with a  $100\mu\text{F}$  capacitor. When connected to a 50Hz supply, the potential difference across the coil is equal to the potential difference across the capacitor. Find the resistance and inductance of the coil.

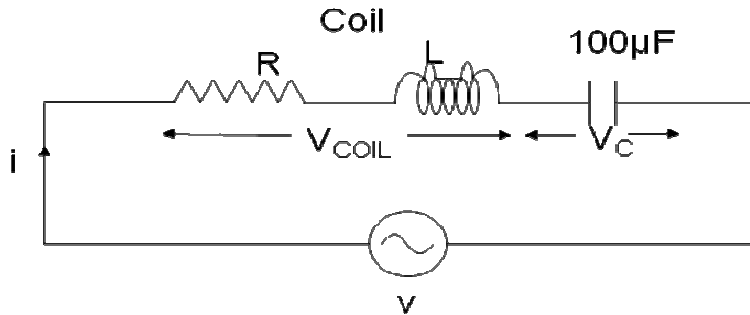

$$\begin{aligned}\cos\Phi_{\text{coil}} &= 0.6 \\ C &= 100\mu\text{F} \\ f &= 50\text{Hz} \\ V_{\text{coil}} &= V_c\end{aligned}$$

$$X_C = \frac{1}{2\pi f C} = \frac{1}{2 \times 3.14 \times 50 \times 100 \times 10^{-6}} = 31.83\Omega$$

$$V_{\text{coil}} = V_c$$

$$IZ_{\text{coil}} = IX_C$$

$$Z_{\text{coil}} = X_C = 31.83\Omega$$

$$R = Z_{\text{coil}} \cos\Phi_{\text{coil}} = 31.83 \times 0.6 = 19.09\Omega$$

$$X_L = \sqrt{Z_{\text{coil}}^2 - R^2} = \sqrt{31.83^2 - 19.09^2} = 25.46\Omega$$

$$L = \frac{1}{2\pi f L} = \frac{1}{2 \times 3.14 \times 50 \times 25.46} = 0.081\text{H}$$

### Problem 11

A current of  $(120-j50)\text{A}$  flows through a circuit when the applied voltage is  $(8+j12)\text{V}$ . Determine (i) impedance (ii) power factor (iii) power consumed and reactive power

$$\bar{V} = 8 + j12$$

$$\bar{I} = 120 - j50$$

$$(i) \bar{Z} = \frac{\bar{V}}{\bar{I}} = \frac{8 + j12}{120 - j50} = 0.02 + j0.11 = 0.11 \angle 79.7^\circ$$

$$Z = 0.11 \Omega$$

$$\Phi = 79.7^\circ$$

$$(ii) pf = \cos \Phi = \cos 79.7^\circ = 0.179 \text{ lag}$$

$$(iii) S = VI^* = (8 + j12) \times (120 + j50) = 360 + j1840$$

$$S = P + jQ$$

$$P = 360 \text{ W}$$

$$Q = 1840 \text{ VAR}$$

### Problem 12

The complex Volt Amperes in a series circuit are  $(4330 - j2500)$  and the current is  $(25 + j43.3) \text{ A}$ .

Find the applied voltage.

$$\bar{S} = 4330 + j2500$$

$$\bar{I} = 25 + j43.3$$

$$\bar{V} = \frac{\bar{S}}{\bar{I}^*} = \frac{4330 + j2500}{25 - j43.3} = 86.6 + j50$$

### Problem 13

A parallel circuit comprises of a resistor of  $20 \Omega$  in series with an inductive reactance  $15 \Omega$  in one branch and a resistor of  $30 \Omega$  in series with a capacitive reactance of  $20 \Omega$  in the other branch.

Determine the current and power dissipated in each branch if the total current drawn by the parallel circuit is  $10 \angle -30^\circ \text{ A}$

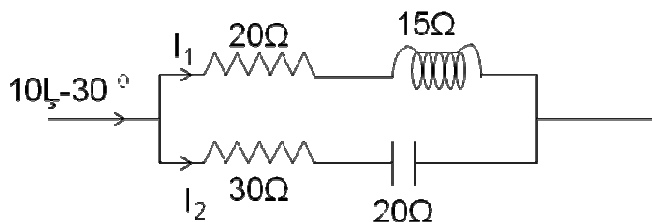

$$Z_1 = 20 + j15$$

$$Z_2 = 30 - j20$$

$$I = 10 \angle -30^\circ = 8.66 - j5$$

$$I_1 = I \frac{Z_2}{Z_1 + Z_2} = (8.66 - j5) \times \frac{(30 - j20)}{(20 + j15) + (30 - j20)}$$

$$I_1 = 3.8 - j6.08 = 7.17 \angle -60^\circ$$

$$I_2 = I - I_1 = (8.66 - j5) - (3.8 - j6.08)$$

$$I_2 = 4.86 + j1.08 = 4.98 \angle -12.5^\circ$$

$$P_1 = I_1^2 R_1 = 7.17^2 \times 20 = 1028.2W$$

$$P_2 = I_2^2 R_2 = 4.98^2 \times 30 = 744W$$

#### Problem 14

A non inductive resistor of  $10\Omega$  is in series with a capacitor of  $100\mu\text{F}$  across a  $250\text{V}$ ,  $50\text{Hz}$  ac supply. Determine the current taken by the capacitor and power factor of the circuit

$$X_C = \frac{1}{2\pi f C} = \frac{1}{2 \times 3.14 \times 50 \times 100 \times 10^{-6}} = 31.83\Omega$$

$$Z = R - jX_C = 10 - j31.83$$

$$I = \frac{V}{Z} = \frac{250}{10 - j31.83} = 2.24 + j7.14 = 7.49 \angle 72.5^\circ$$

$$\phi = 72.5^\circ$$

$$pf = \cos \phi = \cos 72.5^\circ = 0.3$$

#### Problem 15

An impedance coil in parallel with a  $100\mu\text{F}$  capacitor is connected across a  $200\text{V}$ ,  $50\text{Hz}$  supply. The coil takes a current of  $4\text{A}$  and the power loss in the coil is  $600\text{W}$ . Calculate (i) the resistance of the coil (ii) the inductance of the coil (iii) the power factor of the entire circuit.



$$Z_{coil} = \frac{V}{I} = \frac{200}{4} = 50\Omega$$

$$P = I^2 R = 600W$$

$$R = \frac{600}{I^2} = \frac{600}{4^2} = 37.5\Omega$$

$$X_L = \sqrt{Z_{coil}^2 - R^2} = \sqrt{50^2 - 37.5^2} = 33.07\Omega$$

$$L = \frac{X_L}{2\pi f} = \frac{33.07}{2 \times 3.14 \times 50} = 0.105H$$

$$X_C = \frac{1}{2\pi f C} = \frac{1}{2 \times 3.14 \times 50 \times 100 \times 10^{-6}} = 31.83\Omega$$

$$Z_1 = R + jX_L = 37.5 + j33.07$$

$$Z_2 = -jX_C = -j31.83$$

$$Z = \frac{Z_1 Z_2}{Z_1 + Z_2} = \frac{(37.5 + j33.07)(-j31.83)}{(37.5 + j33.07) + (-j31.83)}$$

$$Z = 27 - j32.72 = 42.42 \angle -50.5^\circ$$

$$\Phi = -50.5^\circ$$

$$pf = \cos \Phi = \cos(-50.5^\circ) = 0.6365$$

### Problem 16

A series RLC circuit is connected across a 50Hz supply.  $R=100\Omega$ ,  $L=159.16mH$  and  $C=63.7\mu F$ . If the voltage across C is  $150\angle -90^\circ V$ . Find the supply voltage

$$X_L = 2\pi f L = 2 \times 3.14 \times 50 \times 159.16 \times 10^{-3} = 50\Omega$$

$$X_C = \frac{1}{2\pi f C} = \frac{1}{2 \times 3.14 \times 50 \times 63.7 \times 10^{-6}} = 50\Omega$$

$$V_C = I(-jX_C) = 150 \angle -90^\circ = -j150$$

$$I = \frac{-j150}{-jX_C} = \frac{-j150}{-j50} = 3 \angle 0^\circ A$$

$$Z = R + j(X_L - X_C) = 100 + j(50 - 50) = 100\Omega$$

$$V = IZ = 3 \times 100 = 300V$$

### Problem 17

A circuit having a resistance of  $20\Omega$  and inductance of  $0.07\text{H}$  is connected in parallel with a series combination of  $50\Omega$  resistance and  $60\mu\text{F}$  capacitance. Calculate the total current, when the parallel combination is connected across  $230\text{V}$ ,  $50\text{Hz}$  supply.

$$X_L = 2\pi fL = 2 \times 3.14 \times 50 \times 0.07 = 22\Omega$$

$$X_C = \frac{1}{2\pi fC} = \frac{1}{2 \times 3.14 \times 50 \times 60 \times 10^{-6}} = 53\Omega$$

$$Z_1 = 20 + j22$$

$$Z_2 = 50 - j53$$

$$Z = \frac{Z_1 Z_2}{Z_1 + Z_2} = \frac{(20 + j22)(50 - j53)}{(20 + j22) + (50 - j53)} = 25.7 + j11.9$$

$$I = \frac{V}{Z} = \frac{230}{Z} = 7.4 - j3.4 = 8.13 \angle -24.9^\circ$$

## THREE PHASE AC CIRCUITS

A three phase supply is a set of three alternating quantities displaced from each other by an angle of  $120^\circ$ . A three phase voltage is shown in the figure. It consists of three phases- phase A, phase B and phase C. Phase A waveform starts at  $0^\circ$ . Phase B waveform starts at  $120^\circ$  and phase C waveform at  $240^\circ$ .

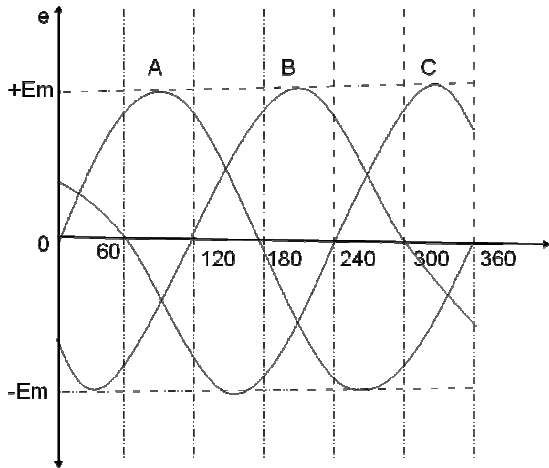

The three phase voltage can be represented by a set of three equations as shown below.

$$e_A = E_m \sin \omega t$$

$$e_B = E_m \sin(\omega t - 120^\circ)$$

$$e_C = E_m \sin(\omega t - 240^\circ) = E_m \sin(\omega t + 120^\circ)$$

The sum of the three phase voltages at any instant is equal to zero.

$$e_A + e_B + e_C = 0$$

The phasor representation of three phase voltages is as shown.

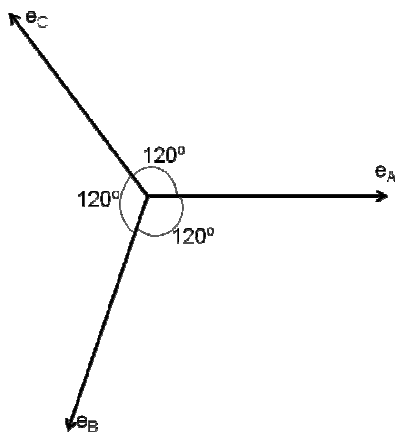

The phase A voltage is taken as the reference and is drawn along the x-axis. The phase B voltage lags behind the phase A voltage by  $120^\circ$ . The phase C voltage lags behind the phase A voltage by  $240^\circ$  and phase B voltage by  $120^\circ$ .

### Generation of Three Phase Voltage

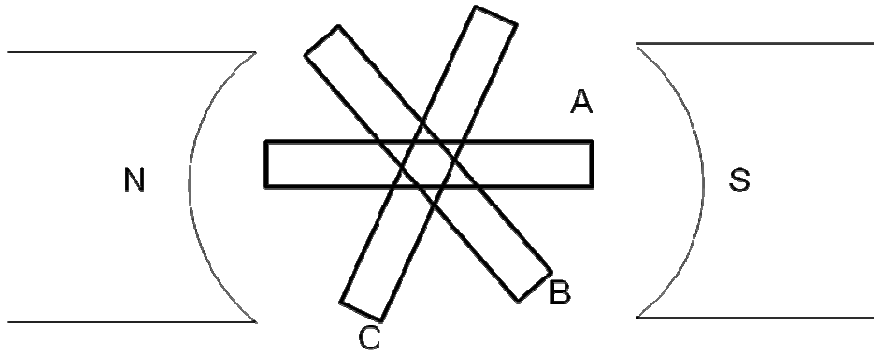

Three Phase voltage can be generated by placing three rectangular coils displaced in space by  $120^\circ$  in a uniform magnetic field. When these coils rotate with a uniform angular velocity of  $\omega$  rad/sec, a sinusoidal emf displaced by  $120^\circ$  is induced in these coils.

### Necessity and advantages of three phase systems

- ❖  $3\Phi$  power has a constant magnitude whereas  $1\Phi$  power pulsates from zero to peak value at twice the supply frequency
- ❖ A  $3\Phi$  system can set up a rotating magnetic field in stationary windings. This is not possible with a  $1\Phi$  supply.
- ❖ For the same rating  $3\Phi$  machines are smaller, simpler in construction and have better operating characteristics than  $1\Phi$  machines
- ❖ To transmit the same amount of power over a fixed distance at a given voltage, the  $3\Phi$  system requires only  $3/4^{\text{th}}$  the weight of copper that is required by the  $1\Phi$  system
- ❖ The voltage regulation of a  $3\Phi$  transmission line is better than that of  $1\Phi$  line

### Phase Sequence

The order in which the voltages in the three phases reach their maximum value

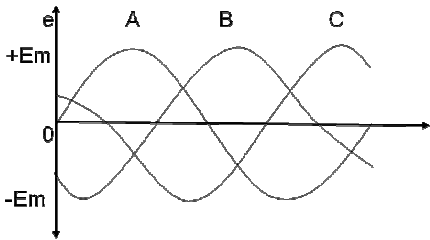

For the waveform shown in figure, phase A reaches the maximum value first, followed by phase B and then by phase C. hence the phase sequence is A-B-C.

### Balanced Supply

A supply is said to be balanced if all three voltages are equal in magnitude and displaced by  $120^\circ$   
A three phase supply can be connected in two ways - Either in Delta connection or in Star connection as shown in the figure.

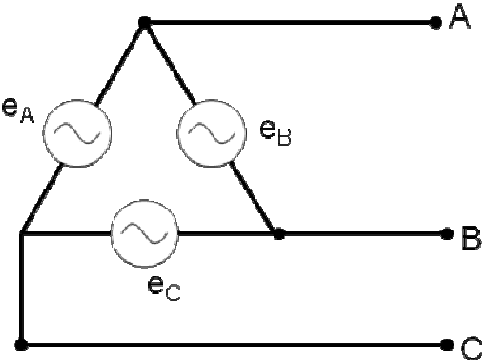

Delta Connection

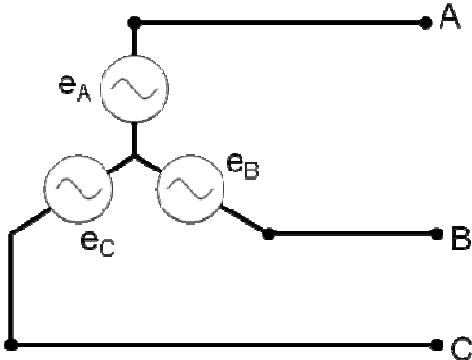

Star Connection

### Balanced Load

A load is said to be balanced if the impedances in all three phases are equal in magnitude and phase  
A three phase load can be connected in two ways - Either in Delta connection or in Star connection as shown in the figure.

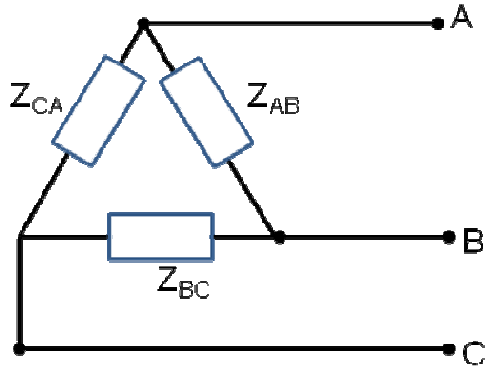

Delta Connection

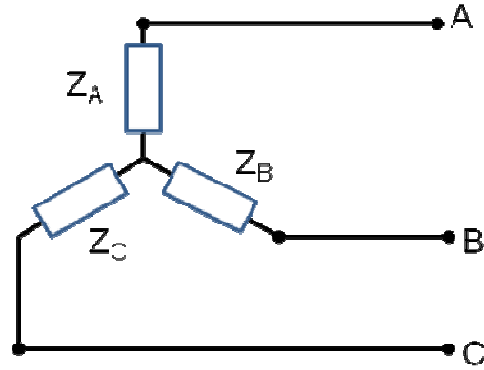

Star Connection

### Balanced Star Connected Load

A balanced star connected load is shown in the figure. A phase voltage is defined as voltage across any phase of the three phase load. The phase voltages shown in figure are  $E_A$ ,  $E_B$  and  $E_C$ . A line voltage is defined as the voltage between any two lines. The line voltages shown in the figure are  $E_{AB}$ ,  $E_{BC}$  and  $E_{CA}$ . The line currents are  $I_A$ ,  $I_B$  and  $I_C$ . For a star connected load, the phase currents are same as the line currents.

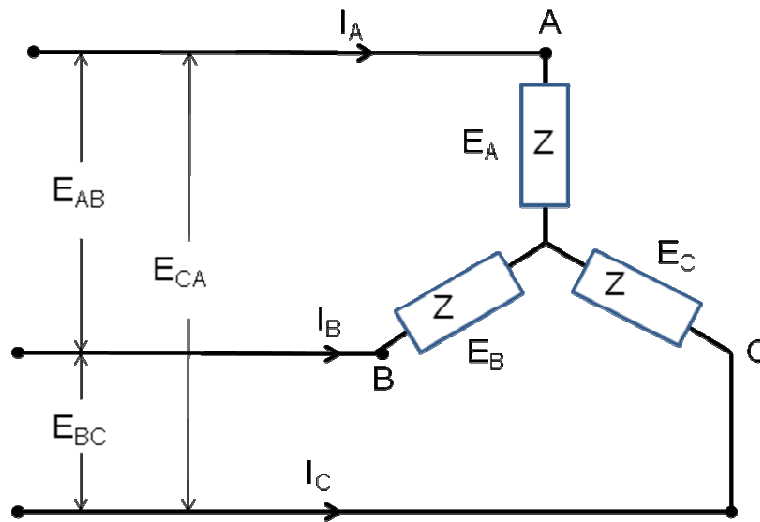

Using Kirchoff's voltage law, the line voltages can be written in terms of the phase voltages as shown below.

$$E_{AB} = E_A - E_B$$

$$E_{BC} = E_B - E_C$$

$$E_{CA} = E_C - E_A$$

The phasor diagram shows the three phase voltages and the line voltage  $E_{AB}$  drawn from  $E_A$  and  $-E_B$  phasors. The phasor for current  $I_A$  is also shown. It is assumed that the load is inductive.

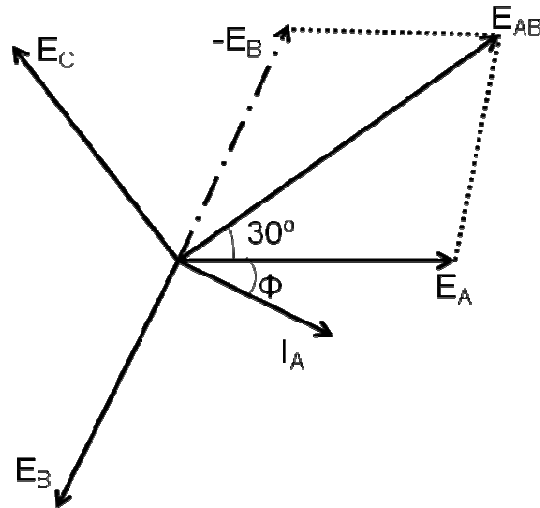

From the phasor diagram we see that the line voltage  $E_{AB}$  leads the phase voltage  $E_A$  by  $30^\circ$ . The magnitude of the two voltages can be related as follows.

$$E_{AB} = 2E_A \cos 30^\circ = \sqrt{3}E_A$$

Hence for a balanced star connected load we can make the following conclusions.

$$E_l = \sqrt{3}E_{ph}$$

$$I_l = I_{ph}$$

Line voltage leads phase voltage by  $30^\circ$

### Three phase Power

In a single phase circuit, the power is given by  $VI\cos\Phi$ . It can also be written as  $V_{ph}I_{ph}\cos\Phi$ . The power in a three circuit will be three times the power in a single phase circuit.

$$P = 3E_{ph}I_{ph} \cos \Phi$$

$$P = \sqrt{3}E_l I_l \cos \Phi$$

### Balanced Delta Connected Load

A balanced delta connected load is shown in the figure. The phase currents are  $I_{AB}$ ,  $I_{BC}$  and  $I_{CA}$ . The line currents are  $I_A$ ,  $I_B$  and  $I_C$ . For a delta connected load, the phase voltages are same as the line voltages given by  $E_{AB}$ ,  $E_{BC}$  and  $E_{CA}$ .

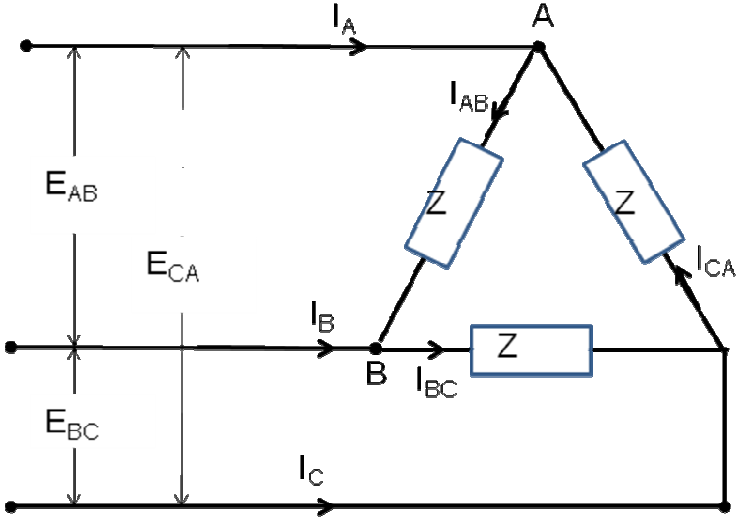

Using Kirchoff's current law, the line currents can be written in terms of the phase currents as shown below.

$$I_A = I_{AB} - I_{CA}$$

$$I_B = I_{BC} - I_{AB}$$

$$I_C = I_{CA} - I_{BC}$$

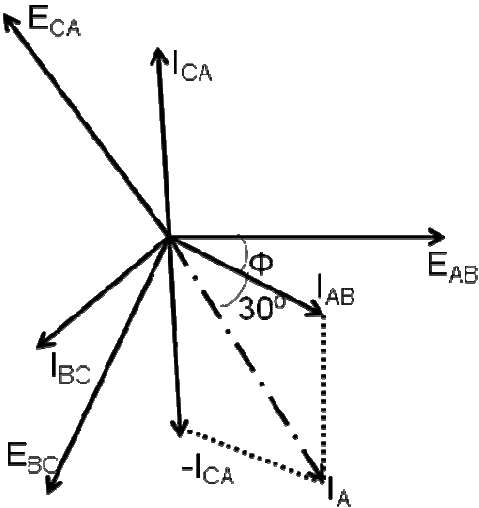



The phasor diagram shows the three voltages  $E_{AB}$ ,  $E_{BC}$  and  $E_{CA}$  and the three phase currents  $I_{AB}$ ,  $I_{BC}$  and  $I_{CA}$  lagging behind the respective phase voltages by an angle  $\Phi$ . This is drawn by assuming that the load is inductive. From the phase currents  $I_{AB}$  and  $-I_{CA}$ , the line current  $I_A$  is drawn as shown in the figure.

From the phasor diagram we see that the line current  $I_A$  lags behind the phase current  $I_{AB}$  by  $30^\circ$ . The magnitude of the two currents can be related as follows.

$$I_A = 2I_{AB} \cos 30^\circ = \sqrt{3}I_{AB}$$

Hence for a balanced delta connected load we can make the following conclusions.

$$I_l = \sqrt{3}I_{ph}$$

$$E_l = E_{ph}$$

Line current lags behind phase current by  $30^\circ$

### Three phase Power

The three phase power for a delta connected load can be derived in the same way as that for a star connected load.

$$P = 3E_{ph}I_{ph} \cos \Phi$$

$$P = \sqrt{3}E_lI_l \cos \Phi$$

### Measurement of power and power factor by two wattmeter method

The power in a three phase circuit can be measured by connecting two wattmeters in any of the two phases of the three phase circuit. A wattmeter consists of a current coil and a potential coil as shown in the figure.

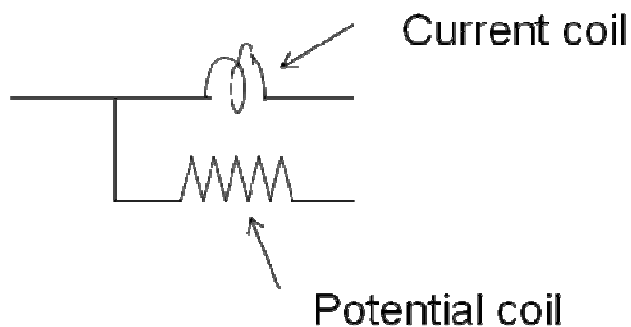

The wattmeter is connected in the circuit in such a way that the current coil is in series and carries the load current and the potential coil is connected in parallel across the load voltage. The wattmeter reading will then be equal to the product of the current carried by the current coil, the voltage across the potential coil and the cosine of the angle between the voltage and current.

The measurement of power is first given for a balanced star connected load and then for a balanced delta connected load.

(i) Balanced star connected load

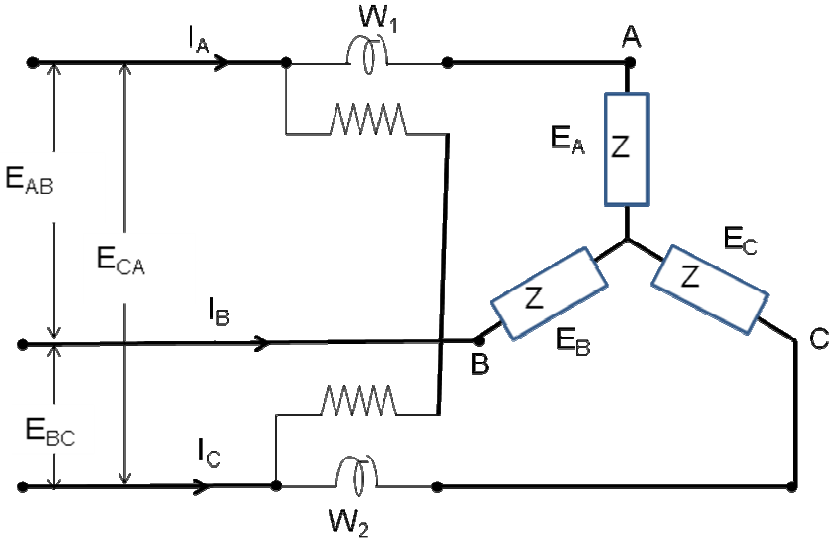

The circuit shows a balanced star connected load for which the power is to be measured. Two wattmeter  $W_1$  and  $W_2$  are connected in phase A and phase C as shown in the figure.

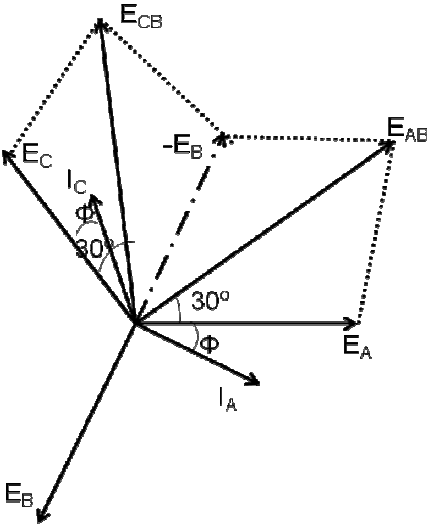

The current coil of wattmeter  $W_1$  carries the current  $I_A$  and its potential coil is connected across the voltage  $E_{AB}$ . A phasor diagram is drawn to determine the angle between  $I_A$  and  $E_{AB}$  as shown.

From the phasor diagram we determine that the angle between the phasors  $I_A$  and  $E_{AB}$  is  $(30+\Phi)$ .

Hence the wattmeter reading  $W_1$  is given by

$$W_1 = E_{AB} I_A \cos(30 + \Phi)$$

The current coil of wattmeter  $W_2$  carries the current  $I_C$  and its potential coil is connected across the voltage  $E_{CB}$ . From the phasor diagram we determine that the angle between the phasors  $I_C$  and  $E_{CB}$  is  $(30-\Phi)$ . Hence the wattmeter reading  $W_2$  is given by

$$W_2 = E_{CB} I_C \cos(30 - \Phi)$$

Line voltages  $E_{AB} = E_{CB} = E_L$

And line currents  $I_A = I_C = I_L$

Hence

$$W_1 = E_L I_L \cos(30 + \Phi)$$

$$W_2 = E_L I_L \cos(30 - \Phi)$$

$$W_1 + W_2 = E_L I_L \cos(30 + \Phi) + E_L I_L \cos(30 - \Phi)$$

$$W_1 + W_2 = E_L I_L (2 \cos 30^\circ \cos \Phi)$$

$$W_1 + W_2 = \sqrt{3} E_L I_L \cos \Phi$$

From the above equations we observe that the sum of the two wattmeter reading gives the three phase power.

#### (ii) Balanced delta connected load

The circuit shows a balanced delta connected load for which the power is to be measured. Two wattmeter  $W_1$  and  $W_2$  are connected in phase A and phase C as shown in the figure.

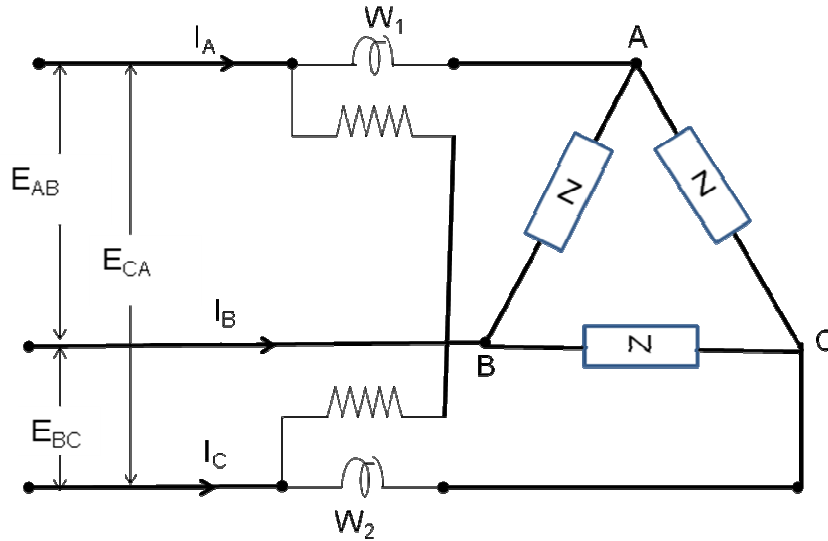

The current coil of wattmeter  $W_1$  carries the current  $I_A$  and its potential coil is connected across the voltage  $E_{AB}$ . A phasor diagram is drawn to determine the angle between  $I_A$  and  $E_{AB}$  as shown.

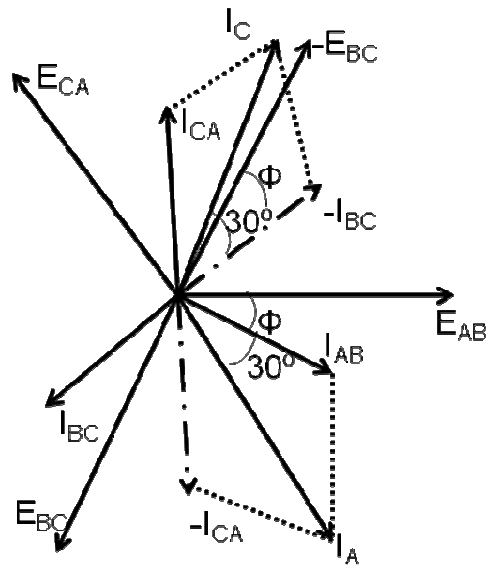

From the phasor diagram we determine that the angle between the phasors  $I_A$  and  $E_{AB}$  is  $(30+\Phi)$ . Hence the wattmeter reading  $W_1$  is given by

$$W_1 = E_{AB} I_A \cos(30 + \Phi)$$

The current coil of wattmeter  $W_2$  carries the current  $I_C$  and its potential coil is connected across the voltage  $E_{CB}$ . From the phasor diagram we determine that the angle between the phasors  $I_C$  and  $E_{CB}$  is  $(30-\Phi)$ . Hence the wattmeter reading  $W_2$  is given by

$$W_2 = E_{CB} I_C \cos(30 - \Phi)$$

Line voltages  $E_{AB} = E_{CB} = E_L$

And line currents  $I_A = I_C = I_L$

Hence

$$W_1 = E_L I_L \cos(30 + \Phi)$$

$$W_2 = E_L I_L \cos(30 - \Phi)$$

$$W_1 + W_2 = E_L I_L \cos(30 + \Phi) + E_L I_L \cos(30 - \Phi)$$

$$W_1 + W_2 = E_L I_L (2 \cos 30^\circ \cos \Phi)$$

$$W_1 + W_2 = \sqrt{3} E_L I_L \cos \Phi$$

From the above equations we observe that the sum of the two wattmeter reading gives the three phase power.

Determination of Real power, Reactive power and Power factor

$$W_1 = E_L I_L \cos(30 + \Phi)$$

$$W_2 = E_L I_L \cos(30 - \Phi)$$

$$W_1 + W_2 = \sqrt{3} E_L I_L \cos \Phi$$

$$W_2 - W_1 = E_L I_L \sin \Phi$$

$$\tan \Phi = \sqrt{3} \left( \frac{W_2 - W_1}{W_1 + W_2} \right)$$

$$\Phi = \tan^{-1} \left[ \sqrt{3} \left( \frac{W_2 - W_1}{W_1 + W_2} \right) \right]$$

$$P = W_1 + W_2$$

$$Q = \sqrt{3} (W_2 - W_1)$$

$$pf = \cos \Phi = \cos \left[ \tan^{-1} \left[ \sqrt{3} \left( \frac{W_2 - W_1}{W_1 + W_2} \right) \right] \right]$$

The power factor can also be determined from the power triangle

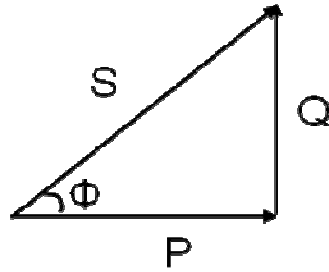

From the power triangle,

$$P = W_1 + W_2$$

$$Q = \sqrt{3}(W_2 - W_1)$$

$$S = \sqrt{(W_1 + W_2)^2 + 3(W_2 - W_1)^2}$$

$$pf = \cos \Phi = \frac{P}{S} = \frac{W_1 + W_2}{\sqrt{(W_1 + W_2)^2 + 3(W_2 - W_1)^2}}$$

Wattmeter readings at different Power Factors

(i) *upf*

$$\Phi = 0^\circ$$

$$W_1 = E_L I_L \cos(30 + \Phi) = E_L I_L \cos(30) = \frac{\sqrt{3}}{2} E_L I_L$$

$$W_2 = E_L I_L \cos(30 - \Phi) = E_L I_L \cos(30) = \frac{\sqrt{3}}{2} E_L I_L$$

$$W_1 = W_2$$

(ii) *pf* = 0.866

$$\Phi = 30^\circ$$

$$W_1 = E_L I_L \cos(30 + \Phi) = E_L I_L \cos(30 + 30) = \frac{E_L I_L}{2}$$

$$W_2 = E_L I_L \cos(30 - \Phi) = E_L I_L \cos(30 - 30) = E_L I_L$$

$$W_2 = 2W_1$$

$$(iii) pf = 0.5$$

$$\Phi = 60^\circ$$

$$W_1 = E_L I_L \cos(30 + \Phi) = E_L I_L \cos(30 + 60) = 0$$

$$W_2 = E_L I_L \cos(30 - \Phi) = E_L I_L \cos(30 - 60) = \frac{\sqrt{3}}{2} E_L I_L$$

$$(iv) pf < 0.5$$

$$\Phi > 60^\circ$$

$$W_1 = E_L I_L \cos(30 + \Phi) < 0$$

$$W_2 = E_L I_L \cos(30 - \Phi) > 0$$

$$(v) pf = 0$$

$$\Phi = 90^\circ$$

$$W_1 = E_L I_L \cos(30 + \Phi) = E_L I_L \cos(30 + 90) = \frac{E_L I_L}{2}$$

$$W_2 = E_L I_L \cos(30 - \Phi) = E_L I_L \cos(30 - 90) = -\frac{E_L I_L}{2}$$

$$W_1 = -W_2$$

### Problem 1

A balanced 3 $\Phi$  delta connected load has per phase impedance of  $(25+j40)\Omega$ . If 400V, 3 $\Phi$  supply is connected to this load, find (i) phase current (ii) line current (iii) power supplied to the load.

$$Z_{ph} = \sqrt{25^2 + 40^2} = 47.17\Omega$$

$$\Phi = \tan^{-1}\left(\frac{40}{25}\right) = 60^\circ$$

$$Z_{ph} = 47.17 \angle 60^\circ \Omega$$

$$E_L = 400V = E_{ph}$$

$$(i) I_{ph} = \frac{E_{ph}}{Z_{ph}} = \frac{400}{47.17 \angle 60^\circ} = 8.48 \angle -60^\circ A$$

$$(ii) I_L = \sqrt{3} I_{ph} = \sqrt{3} \times 8.48 = 14.7 \angle -90^\circ A$$

$$(iii) P = \sqrt{3} E_L I_L \cos \Phi = \sqrt{3} \times 400 \times 14.7 \times \cos 60^\circ$$

$$P = 5397.76W$$

### Problem 2

Two wattmeter method is used to measure the power absorbed by a 3 $\Phi$  induction motor. The wattmeter readings are 12.5kW and -4.8kW. Find (i) the power absorbed by the machine (ii) load power factor (iii) reactive power taken by the load.

$$W_1 = 12.5kW$$

$$W_2 = -4.8kW$$

$$(i) P = W_1 + W_2 = 12.5 - 4.8 = 7.7kW$$

$$(ii) \tan \Phi = \sqrt{3} \left( \frac{W_2 - W_1}{W_1 + W_2} \right) = \sqrt{3} \left( \frac{-4.8 - 12.5}{12.5 - 4.8} \right) = -3.89$$

$$\Phi = \tan^{-1}[-3.89] = -75.6^\circ$$

$$pf = \cos \Phi = \cos(-75.6^\circ) = 0.2487$$

$$(iii) Q = \sqrt{3}(W_2 - W_1) = \sqrt{3}(-4.8 - 12.5) = 29.96kVAR$$

### Problem 3

Calculate the active and reactive components of each phase of a star connected 10kV, 3 $\Phi$  alternator supplying 5MW at 0.8 pf.

$$E_L = 10kV$$

$$P = 5MW$$

$$pf = \cos \Phi = 0.8$$

$$\Phi = 36.87^\circ$$

$$P = \sqrt{3}E_L I_L \cos \Phi$$

$$I_L = \frac{P}{\sqrt{3}E_L \cos \Phi} = \frac{5 \times 10^6}{\sqrt{3} \times 10 \times 10^3 \times 0.8} = 360.84A$$

$$P_{ph} = \frac{5 \times 10^6}{3} = 166.7MW$$

$$Q_{ph} = E_{ph} I_{ph} \sin \Phi = \frac{10 \times 10}{\sqrt{3}} \times 360.8 \times \sin 36.87^\circ = 1.25MVAR$$

### Problem 4

A 3 $\Phi$  load of three equal impedances connected in delta across a balanced 400V supply takes a line current of 10A at a power factor of 0.7 lagging. calculate (i) the phase current (ii) the total power (iii) the total reactive kVAR



$$E_L = 400V = E_{ph}$$

$$I_L = 10A$$

$$pf = \cos \Phi = 0.7 \text{ lag}$$

$$\Phi = 45.57^\circ$$

$$(i) I_{ph} = \frac{I_L}{\sqrt{3}} = \frac{10}{\sqrt{3}} = 5.8A$$

$$(ii) P = \sqrt{3} E_L I_L \cos \Phi = \sqrt{3} \times 400 \times 10 \times 0.7 = 4.84kW$$

$$(iii) Q = \sqrt{3} E_L I_L \sin \Phi = \sqrt{3} \times 400 \times 10 \times \sin 45.57^\circ = 4.94kVAR$$

### Problem 5

The power flowing in a 3 $\Phi$ , 3 wire balanced load system is measured by two wattmeter method. The reading in wattmeter A is 750W and wattmeter B is 1500W. What is the power factor of the system?

$$W_1 = 750W$$

$$W_2 = 1500W$$

$$\Phi = \tan^{-1} \left[ \sqrt{3} \left( \frac{W_2 - W_1}{W_1 + W_2} \right) \right] = \tan^{-1} \left[ \sqrt{3} \left( \frac{1500 - 750}{750 + 1500} \right) \right]$$

$$\Phi = 30^\circ$$

$$pf = \cos \Phi = \cos 30^\circ = 0.866$$

### Problem 6

A 3 $\Phi$  star connected supply with a phase voltage of 230V is supplying a balanced delta connected load. The load draws 15kW at 0.8pf lagging. Find the line currents and the current in each phase of the load. What is the load impedance per phase.

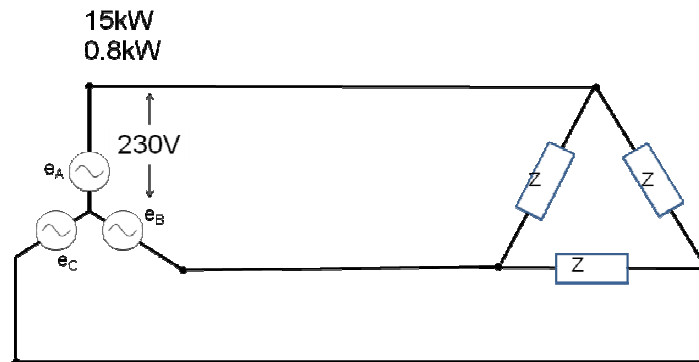

*Alternator*

$$E_{ph} = 230V$$

$$E_L = \sqrt{3} \times 230V = 398.37V$$

$$P = 15kW$$

$$pf = \cos \Phi = 0.8 \text{lagging}$$

$$I_L = \frac{P}{\sqrt{3}E_L \cos \Phi} = 27.17A$$

*Load*

$$E_{ph} = E_L = 398.37V$$

$$I_L = 27.17A$$

$$I_{ph} = \frac{I_L}{\sqrt{3}} = 15.68A$$

$$Z_{ph} = \frac{E_{ph}}{I_{ph}} = 25.4\Omega$$