

# ALTERNATING CURRENTS

1. Alternating EMF and Current
2. Average or Mean Value of Alternating EMF and Current
3. Root Mean Square Value of Alternating EMF and Current
4. A C Circuit with Resistor
5. A C Circuit with Inductor
6. A C Circuit with Capacitor
7. A C Circuit with Series LCR – Resonance and Q-Factor
8. Graphical Relation between Frequency vs  $X_L$ ,  $X_C$
9. Power in LCR A C Circuit
10. Watt-less Current
11. L C Oscillations
12. Transformer
13. A.C. Generator

## Alternating emf:

Alternating emf is that emf which continuously changes in magnitude and periodically reverses its direction.

## Alternating Current:

Alternating current is that current which continuously changes in magnitude and periodically reverses its direction.

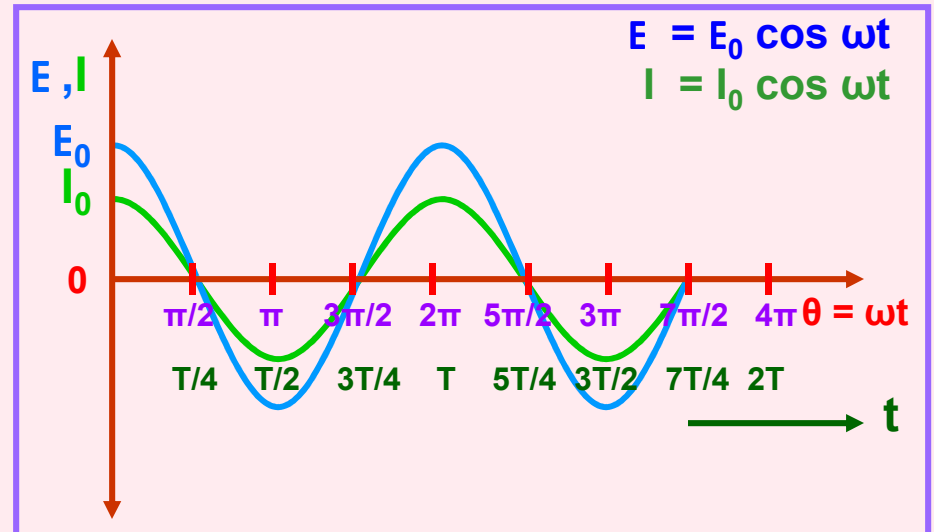
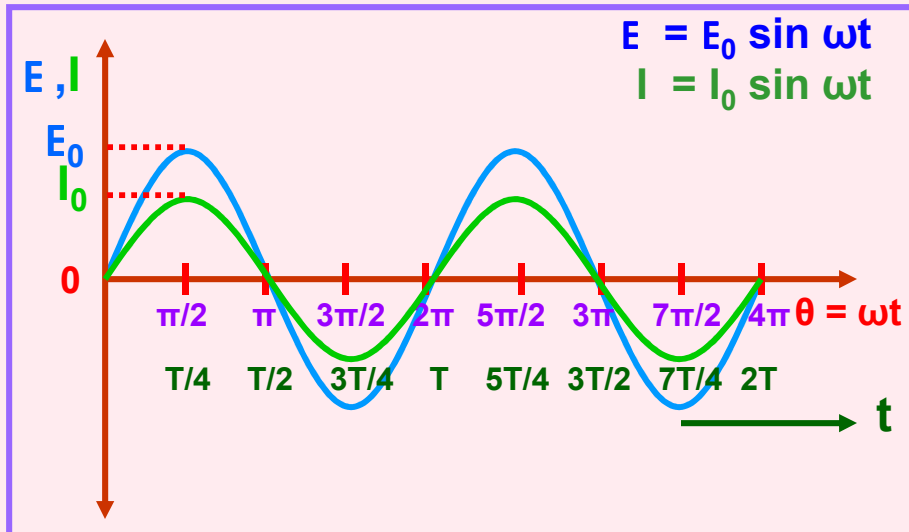

$E, I$  – Instantaneous value of emf and current  
 $E_0, I_0$  – Peak or maximum value or amplitude of emf and current  
 $\omega$  – Angular frequency       $t$  – Instantaneous time  
 $\omega t$  – Phase

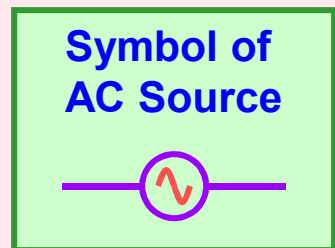

## Average or Mean Value of Alternating Current:

Average or Mean value of alternating current over half cycle is that steady current which will send the same amount of charge in a circuit in the time of half cycle as is sent by the given alternating current in the same circuit in the same time.

$$dq = I dt = I_0 \sin \omega t dt$$

$$q = \int_0^{T/2} I_0 \sin \omega t dt$$

$$q = 2 I_0 / \omega = 2 I_0 T / 2\pi = I_0 T / \pi$$

$$\text{Mean Value of AC, } I_m = I_{av} = q / (T/2)$$

$$I_m = I_{av} = 2 I_0 / \pi = 0.637 I_0 = 63.7 \% I_0$$

## Average or Mean Value of Alternating emf:

$$E_m = E_{av} = 2 E_0 / \pi = 0.637 E_0 = 63.7 \% E_0$$

Note: Average or Mean value of alternating current or emf is zero over a cycle as the + ve and – ve values get cancelled.

## Root Mean Square or Virtual or Effective Value of Alternating Current:

Root Mean Square (rms) value of alternating current is that steady current which would produce the same heat in a given resistance in a given time as is produced by the given alternating current in the same resistance in the same time.

$$dH = I^2 R dt = I_0^2 R \sin^2 \omega t dt$$

$$H = \int_0^T I_0^2 R \sin^2 \omega t dt$$

$$H = I_0^2 RT / 2 \quad (\text{After integration, } \omega \text{ is replaced with } 2\pi / T)$$

If  $I_v$  be the virtual value of AC, then

$$H = I_v^2 RT \quad \therefore \quad I_v = I_{\text{rms}} = I_{\text{eff}} = I_0 / \sqrt{2} = 0.707 I_0 = 70.7 \% I_0$$

## Root Mean Square or Virtual or Effective Value of Alternating emf:

$$E_v = E_{\text{rms}} = E_{\text{eff}} = E_0 / \sqrt{2} = 0.707 E_0 = 70.7 \% E_0$$

**Note:**

1. Root Mean Square value of alternating current or emf can be calculated over any period of the cycle since it is based on the heat energy produced.

2. Do not use the above formulae if the time interval under the consideration is less than one period.

## Relative Values Peak, Virtual and Mean Values of Alternating emf:

$$E_m = E_{av} = 0.637 E_0$$

$$E_v = E_{rms} = E_{eff} = 0.707 E_0$$

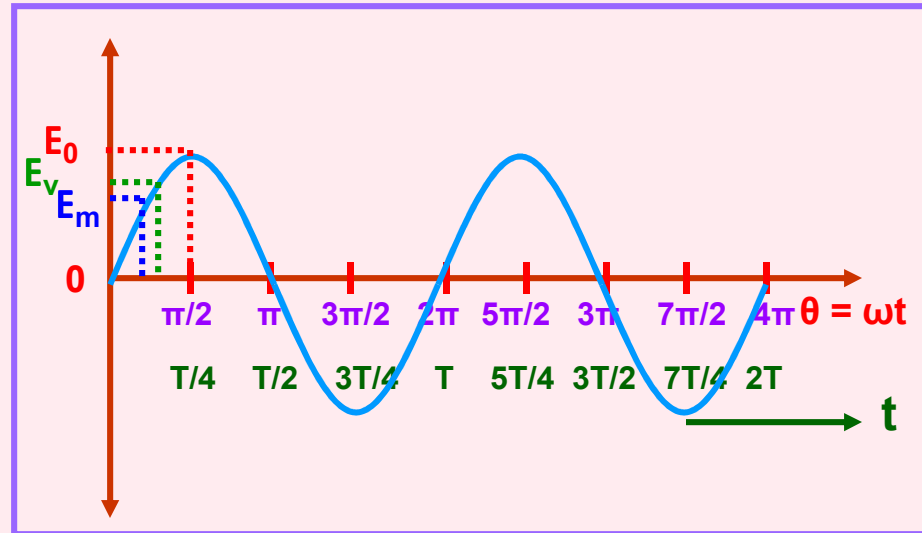

### Tips:

1. The given values of alternating emf and current are virtual values unless otherwise specified.  
i.e. 230 V AC means  $E_v = E_{rms} = E_{eff} = 230 \text{ V}$
2. AC Ammeter and AC Voltmeter read the rms values of alternating current and voltage respectively.  
They are called as 'hot wire meters'.
3. The scale of DC meters is linearly graduated whereas the scale of AC meters is not evenly graduated because  $H \propto I^2$

## AC Circuit with a Pure Resistor:

$$E = E_0 \sin \omega t$$

$$I = E / R$$

$$= (E_0 / R) \sin \omega t$$

$$I = I_0 \sin \omega t \quad (\text{where } I_0 = E_0 / R \quad \text{and} \quad R = E_0 / I_0)$$

Emf and current are in same phase.

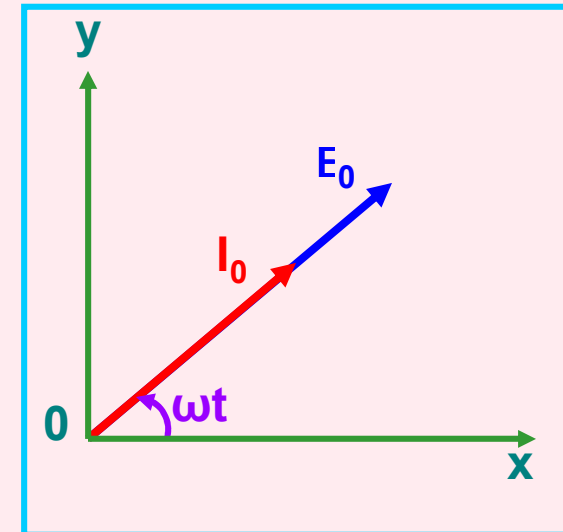
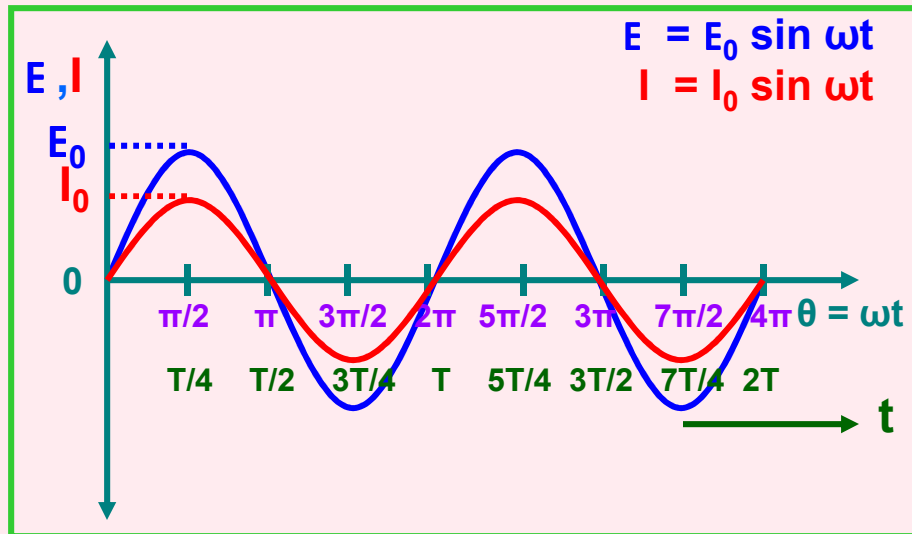
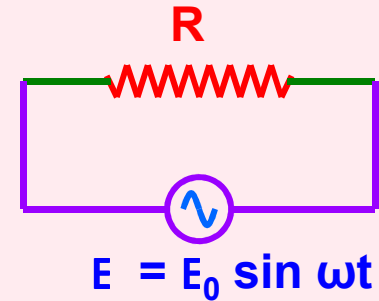

## AC Circuit with a Pure Inductor:

$$E = E_0 \sin \omega t$$

Induced emf in the inductor is  $-L (di / dt)$

In order to maintain the flow of current, the applied emf must be equal and opposite to the induced emf.

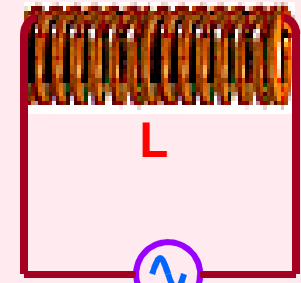

$$E = E_0 \sin \omega t$$

$$\therefore E = L (di / dt)$$

$$E_0 \sin \omega t = L (di / dt)$$

$$di = (E_0 / L) \sin \omega t dt$$



$$i = \int (E_0 / L) \sin \omega t dt$$

$$i = (E_0 / \omega L) (-\cos \omega t)$$

$$i = I_0 \sin (\omega t - \pi / 2)$$

(where  $I_0 = E_0 / \omega L$  and  $X_L = \omega L = E_0 / I_0$ )  
 $X_L$  is Inductive Reactance. Its SI unit is ohm.

Current lags behind emf by  $\pi/2$  rad.

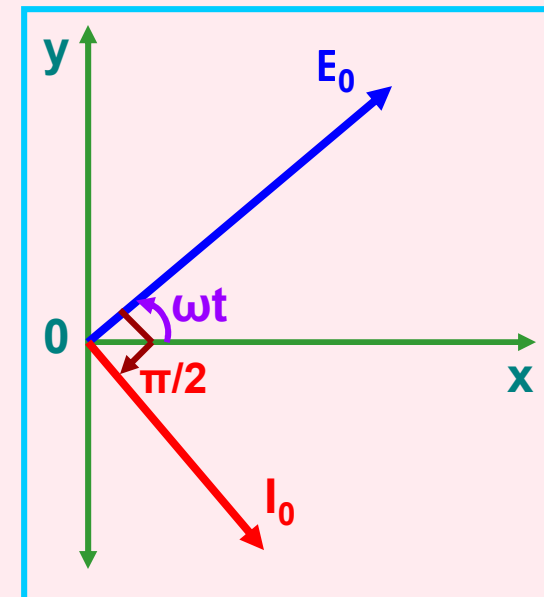
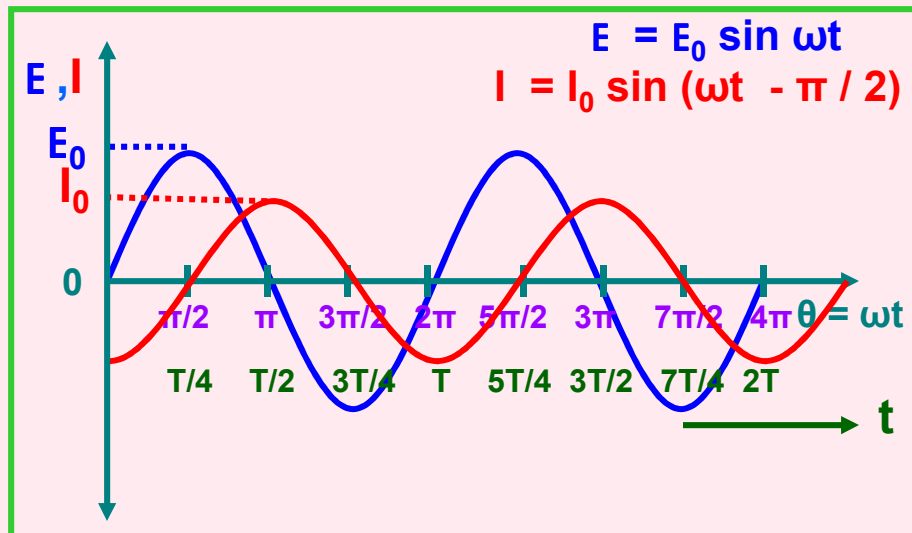

## AC Circuit with a Capacitor:

$$E = E_0 \sin \omega t$$

$$q = CE = CE_0 \sin \omega t$$

$$I = dq / dt$$

$$= (d / dt) [CE_0 \sin \omega t]$$

$$I = [E_0 / (1 / \omega C)] (\cos \omega t)$$

$$I = I_0 \sin (\omega t + \pi / 2)$$

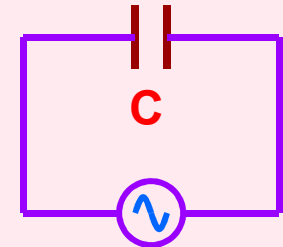

$$E = E_0 \sin \omega t$$

(where  $I_0 = E_0 / (1 / \omega C)$  and

$$X_C = 1 / \omega C = E_0 / I_0)$$

$X_C$  is Capacitive Reactance.

Its SI unit is ohm.

Current leads the emf by  $\pi/2$  radians.

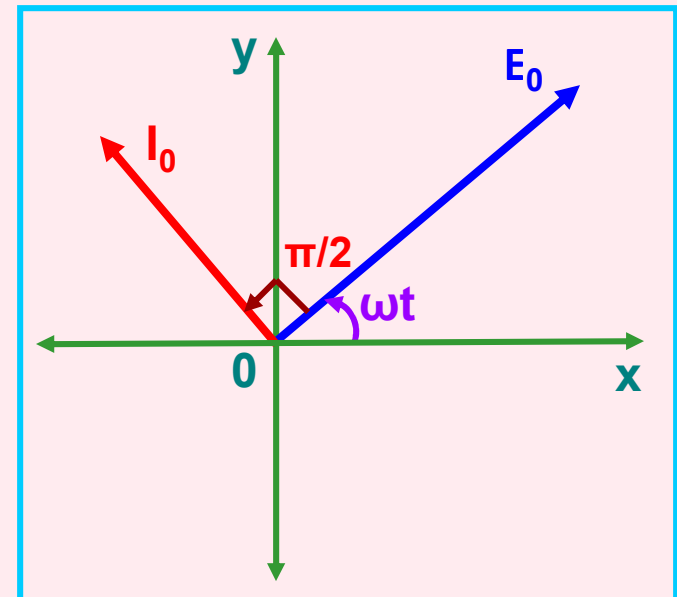
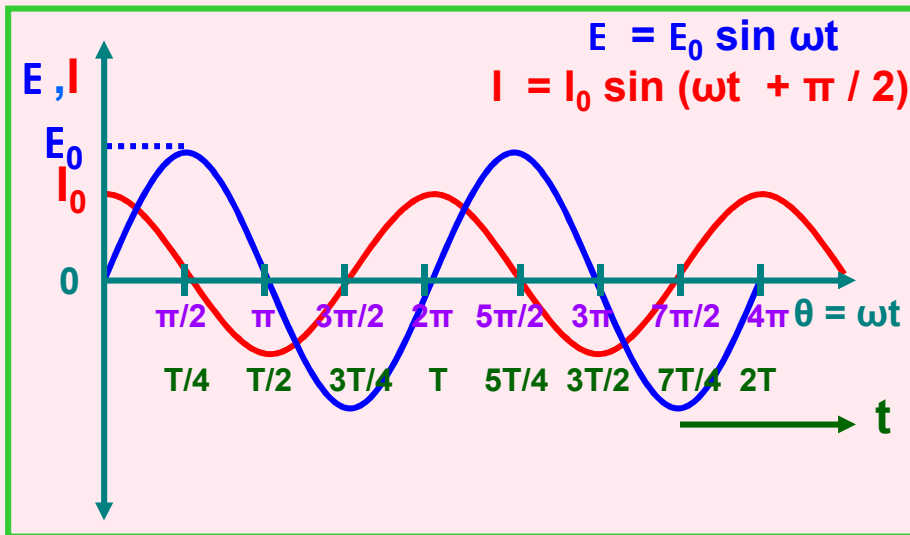



### Variation of $X_L$ with Frequency:

$$I_0 = E_0 / \omega L \quad \text{and} \quad X_L = \omega L$$

$X_L$  is Inductive Reactance and  $\omega = 2\pi f$

$$X_L = 2\pi f L \quad \text{i.e.} \quad X_L \propto f$$

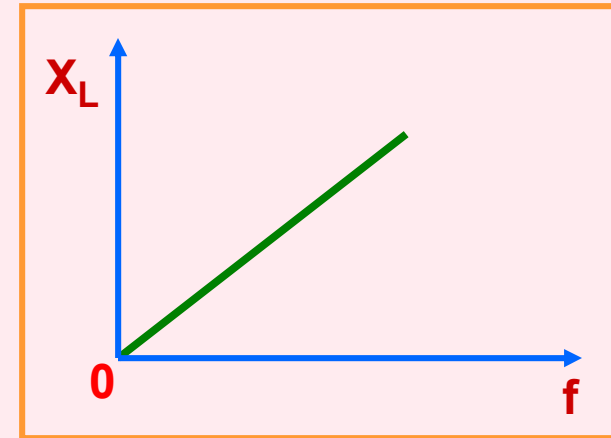

### Variation of $X_C$ with Frequency:

$$I_0 = E_0 / (1/\omega C) \quad \text{and} \quad X_C = 1 / \omega C$$

$X_C$  is Inductive Reactance and  $\omega = 2\pi f$

$$X_C = 1 / 2\pi f C \quad \text{i.e.} \quad X_C \propto 1 / f$$

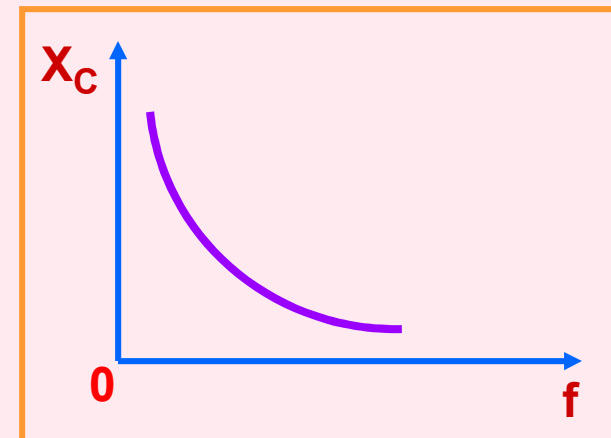

#### TIPS:

- 1) Inductance (L) can not decrease Direct Current. It can only decrease Alternating Current.
- 2) Capacitance (C) allows AC to flow through it but blocks DC.

## AC Circuit with L, C, R in Series Combination:

The applied emf appears as Voltage drops  $V_R$ ,  $V_L$  and  $V_C$  across R, L and C respectively.

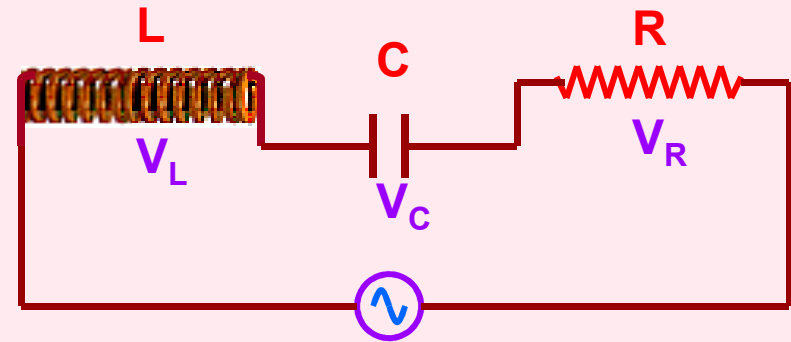

$$E = E_0 \sin \omega t$$

- 1) In R, current and voltage are in phase.
- 2) In L, current lags behind voltage by  $\pi/2$
- 3) In C, current leads the voltage by  $\pi/2$

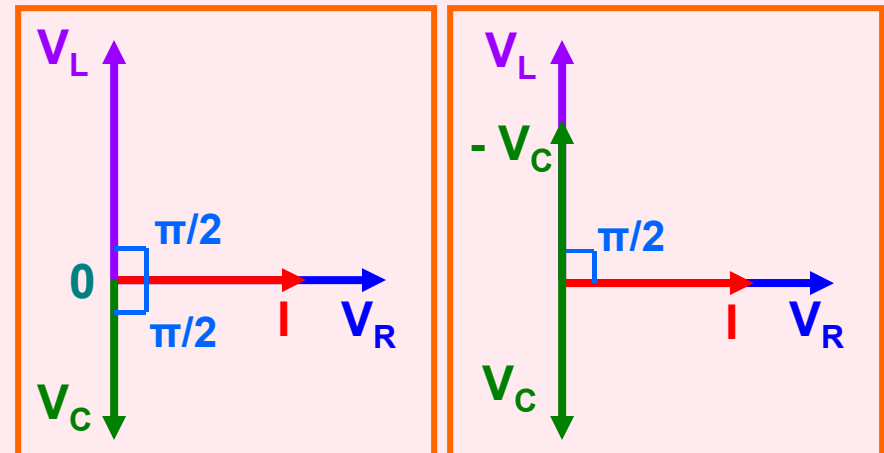

$$E = \sqrt{V_R^2 + (V_L - V_C)^2}$$

$$I = \frac{E}{\sqrt{R^2 + (X_L - X_C)^2}}$$

$$Z = \sqrt{R^2 + (X_L - X_C)^2}$$

$$Z = \sqrt{R^2 + (\omega L - 1/\omega C)^2}$$

$$\tan \Phi = \frac{X_L - X_C}{R} \quad \text{or} \quad \tan \Phi = \frac{\omega L - 1/\omega C}{R}$$

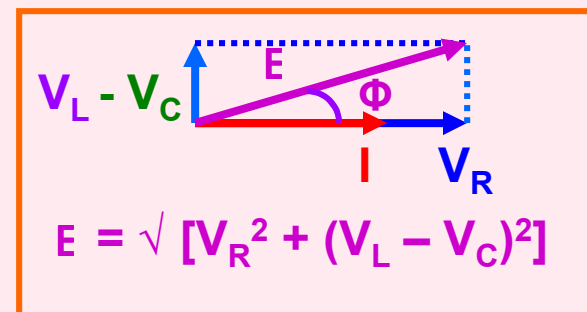

$$\tan \Phi = \frac{X_L - X_C}{R}$$

or

$$\tan \Phi = \frac{\omega L - 1/\omega C}{R}$$

### Special Cases:

**Case I:** When  $X_L > X_C$  i.e.  $\omega L > 1/\omega C$ ,

$$\tan \Phi = +ve \text{ or } \Phi \text{ is } +ve$$

The current lags behind the emf by phase angle  $\Phi$  and the LCR circuit is inductance - dominated circuit.

**Case II:** When  $X_L < X_C$  i.e.  $\omega L < 1/\omega C$ ,

$$\tan \Phi = -ve \text{ or } \Phi \text{ is } -ve$$

The current leads the emf by phase angle  $\Phi$  and the LCR circuit is capacitance - dominated circuit.

**Case III:** When  $X_L = X_C$  i.e.  $\omega L = 1/\omega C$ ,

$$\tan \Phi = 0 \text{ or } \Phi \text{ is } 0^\circ$$

The current and the emf are in same phase. The impedance does not depend on the frequency of the applied emf. LCR circuit behaves like a purely resistive circuit.

## Resonance in AC Circuit with L, C, R:

When  $X_L = X_C$  i.e.  $\omega L = 1/\omega C$ ,  $\tan \Phi = 0$  or  $\Phi$  is  $0^\circ$  and

$$Z = \sqrt{[R^2 + (\omega L - 1/\omega C)^2]} \text{ becomes } Z_{\min} = R \text{ and } I_{0\max} = E / R$$

i.e. The impedance offered by the circuit is minimum and the current is maximum. This condition is called resonant condition of LCR circuit and the frequency is called resonant frequency.

At resonant angular frequency  $\omega_r$ ,

$$\omega_r L = 1/\omega_r C \text{ or } \omega_r = 1 / \sqrt{LC} \text{ or } f_r = 1 / (2\pi \sqrt{LC})$$

### Resonant Curve & Q - Factor:

$$\text{Band width} = 2 \Delta \omega$$

Quality factor (Q – factor) is defined as the ratio of resonant frequency to band width.

$$Q = \omega_r / 2 \Delta \omega$$

It can also be defined as the ratio of potential drop across either the inductance or the capacitance to the potential drop across the resistance.

$$Q = V_L / V_R \text{ or } Q = V_C / V_R$$

$$\text{or } Q = \omega_r L / R \text{ or } Q = 1 / \omega_r C R$$

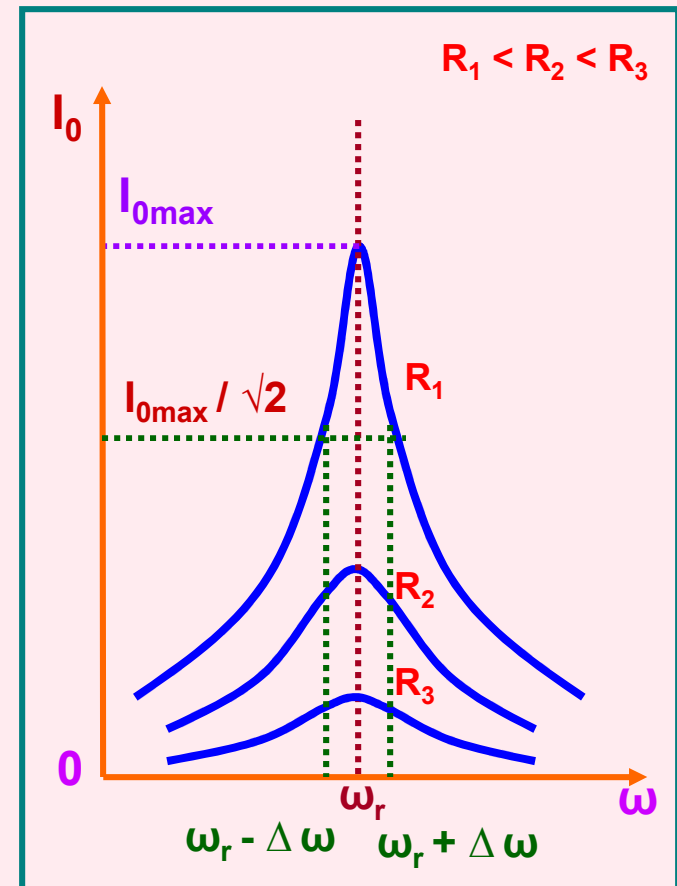

## Power in AC Circuit with L, C, R:

$$E = E_0 \sin \omega t$$

$$I = I_0 \sin (\omega t + \Phi) \quad (\text{where } \Phi \text{ is the phase angle between emf and current})$$

$$\text{Instantaneous Power} = EI$$

$$= E_0 I_0 \sin \omega t \sin (\omega t + \Phi)$$

$$= E_0 I_0 [\sin^2 \omega t \cos \Phi + \sin \omega t \cos \omega t \cos \Phi]$$

If the instantaneous power is assumed to be constant for an infinitesimally small time  $dt$ , then the work done is

$$dW = E_0 I_0 [\sin^2 \omega t \cos \Phi + \sin \omega t \cos \omega t \cos \Phi]$$

Work done over a complete cycle is

$$W = \int_0^T E_0 I_0 [\sin^2 \omega t \cos \Phi + \sin \omega t \cos \omega t \cos \Phi] dt$$

$$W = E_0 I_0 \cos \Phi \times T / 2$$

Average Power over a cycle is  $P_{av} = W / T$

$$P_{av} = (E_0 I_0 / 2) \cos \Phi$$

(where  $\cos \Phi = R / Z$ )

$$P_{av} = (E_0 / \sqrt{2}) (I_0 / \sqrt{2}) \cos \Phi$$

$$= R / \sqrt{[R^2 + (\omega L - 1/\omega C)^2]}$$

is called Power Factor)

$$P_{av} = E_v I_v \cos \Phi$$

$$P_{av} = E_v I_v \cos \Phi$$

### Power in AC Circuit with R:

In R, current and emf are in phase.

$$\Phi = 0^\circ$$

$$P_{av} = E_v I_v \cos \Phi = E_v I_v \cos 0^\circ = E_v I_v$$

### Power in AC Circuit with L:

In L, current lags behind emf by  $\pi/2$ .

$$\Phi = -\pi/2$$

$$P_{av} = E_v I_v \cos (-\pi/2) = E_v I_v (0) = 0$$

### Power in AC Circuit with C:

In C, current leads emf by  $\pi/2$ .

$$\Phi = +\pi/2$$

$$P_{av} = E_v I_v \cos (\pi/2) = E_v I_v (0) = 0$$

**Note:**

Power (Energy) is not dissipated in Inductor and Capacitor and hence they find a lot of practical applications and in devices using alternating current.

### Wattless Current or Idle Current:

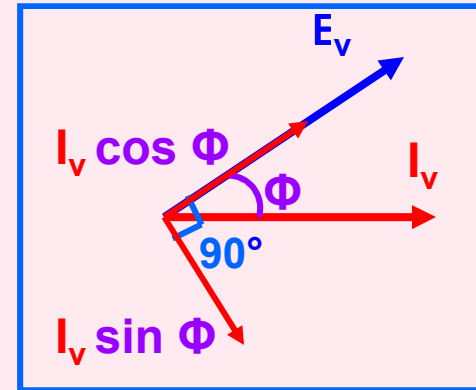

The component  $I_v \cos \Phi$  generates power with  $E_v$ .

However, the component  $I_v \sin \Phi$  does not contribute to power along  $E_v$  and hence power generated is zero. This component of current is called wattless or idle current.

$$P = E_v I_v \sin \Phi \cos 90^\circ = 0$$

# L C Oscillations:

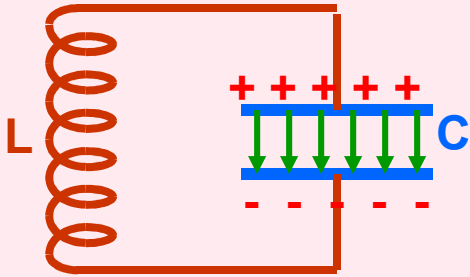

At  $t = 0$ ,  $U_E = \text{Max.}$  &  $U_B = 0$

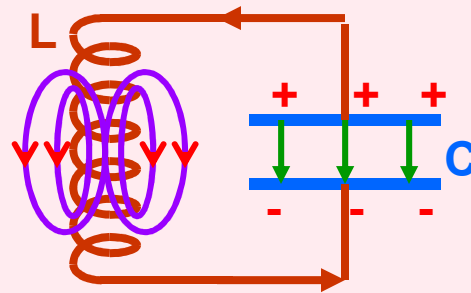

At  $t = T/8$ ,  $U_E = U_B$

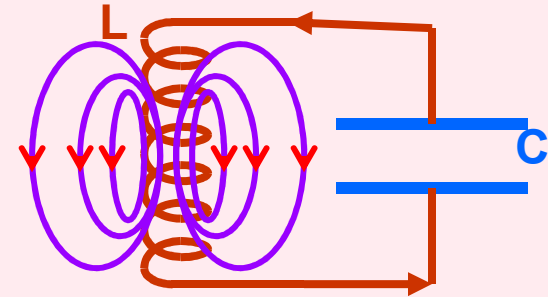

At  $t = 2T/8$ ,  $U_E = 0$  &  $U_B = \text{Max.}$

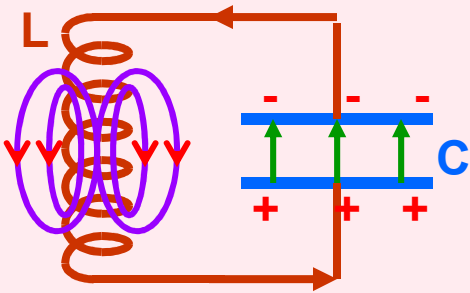

At  $t = 3T/8$ ,  $U_E = U_B$

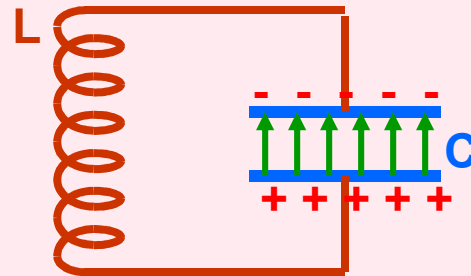

At  $t = 4T/8$ ,  $U_E = \text{Max.}$  &  $U_B = 0$

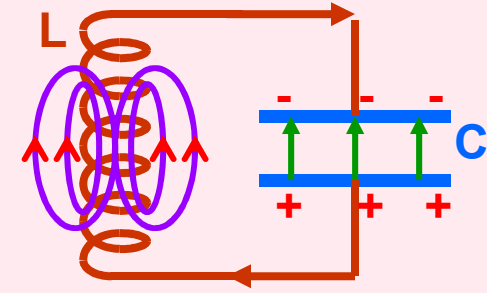

At  $t = 5T/8$ ,  $U_E = U_B$

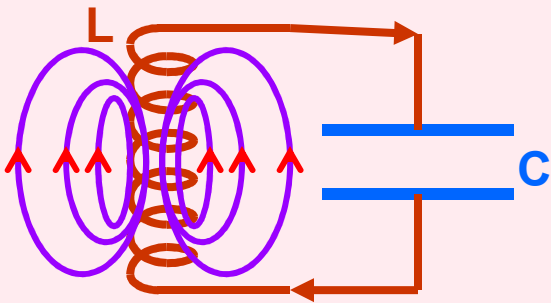

At  $t = 6T/8$ ,  $U_E = 0$  &  $U_B = \text{Max.}$

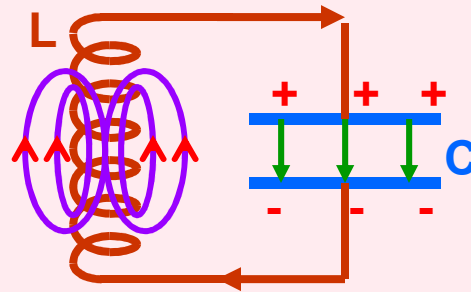

At  $t = 7T/8$ ,  $U_E = U_B$

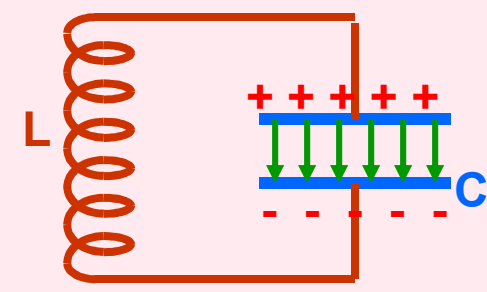

At  $t = T$ ,  $U_E = \text{Max.}$  &  $U_B = 0$

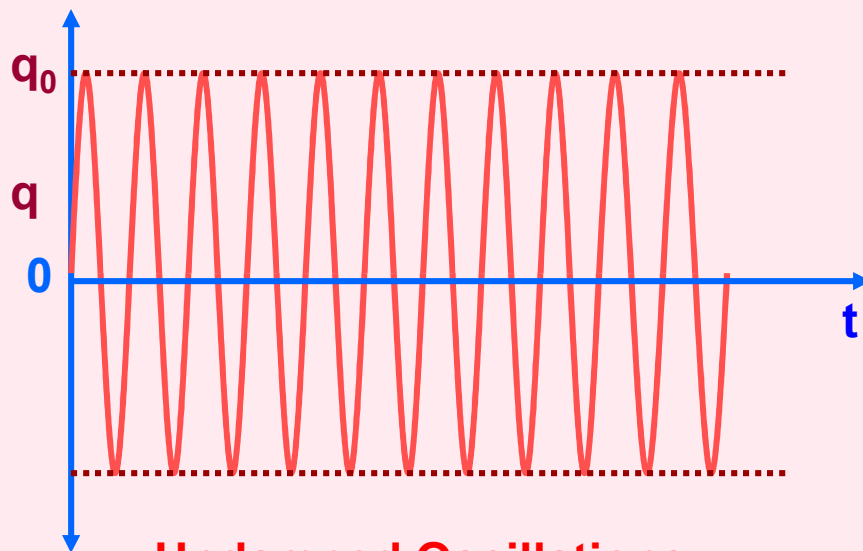

**Undamped Oscillations**

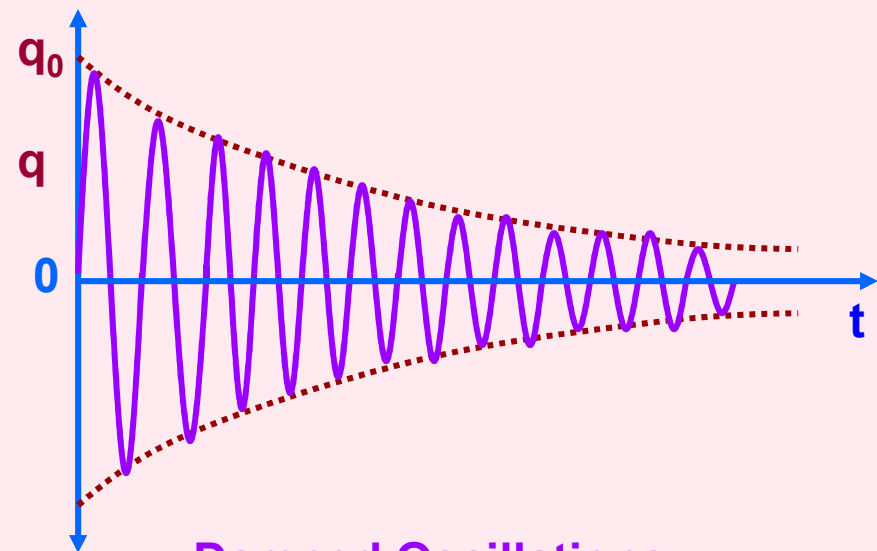

**Damped Oscillations**

If  $q$  be the charge on the capacitor at any time  $t$  and  $di / dt$  the rate of change of current, then

$$L \frac{di}{dt} + \frac{q}{C} = 0$$

$$\text{or } L \left( \frac{d^2q}{dt^2} \right) + \frac{q}{C} = 0$$

$$\text{or } \frac{d^2q}{dt^2} + \frac{q}{LC} = 0$$

$$\text{Putting } \frac{1}{LC} = \omega^2$$

$$\frac{d^2q}{dt^2} + \omega^2 q = 0$$

The final equation represents **Simple Harmonic Electrical Oscillation** with  $\omega$  as angular frequency.

$$\text{So, } \omega = \frac{1}{\sqrt{LC}}$$

$$\text{or } f = \frac{1}{2\pi \sqrt{LC}}$$



# Transformer:

Transformer is a device which converts lower alternating voltage at higher current into higher alternating voltage at lower current.

## Principle:

Transformer is based on Mutual Induction.

It is the phenomenon of inducing emf in the secondary coil due to change in current in the primary coil and hence the change in magnetic flux in the secondary coil.

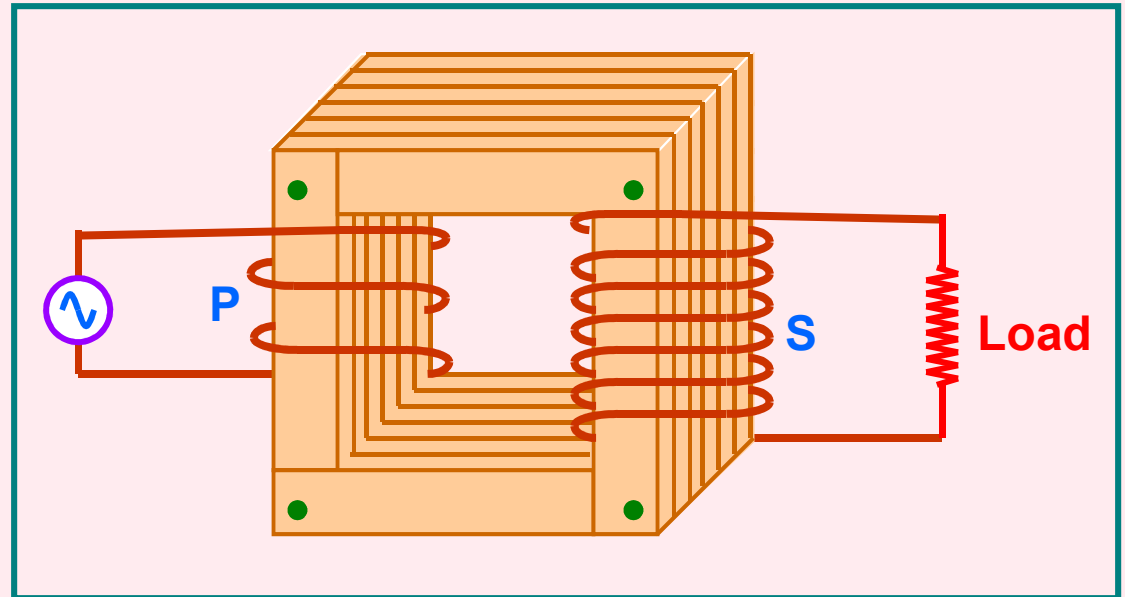

## Theory:

$$E_p = - N_p d\Phi / dt$$

$$E_s = - N_s d\Phi / dt$$

$$E_s / E_p = N_s / N_p = K$$

(where K is called Transformation Ratio or Turns Ratio)

For an ideal transformer,

Output Power = Input Power

$$E_s I_s = E_p I_p$$

$$E_s / E_p = I_p / I_s$$

$$E_s / E_p = I_p / I_s = N_s / N_p$$

Efficiency ( $\eta$ ):

$$\eta = E_s I_s / E_p I_p$$

For an ideal transformer  $\eta$  is 100%

### Step - up Transformer:

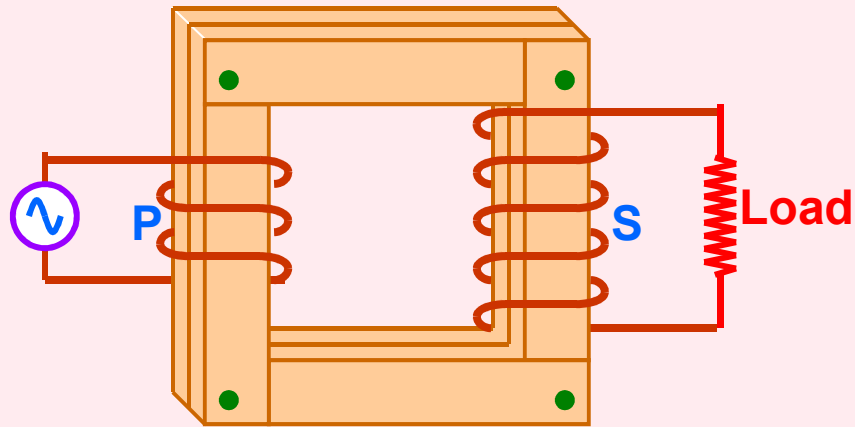

$$N_s > N_p \text{ i.e. } K > 1$$

$$E_s > E_p \text{ \& } I_s < I_p$$

### Step - down Transformer:

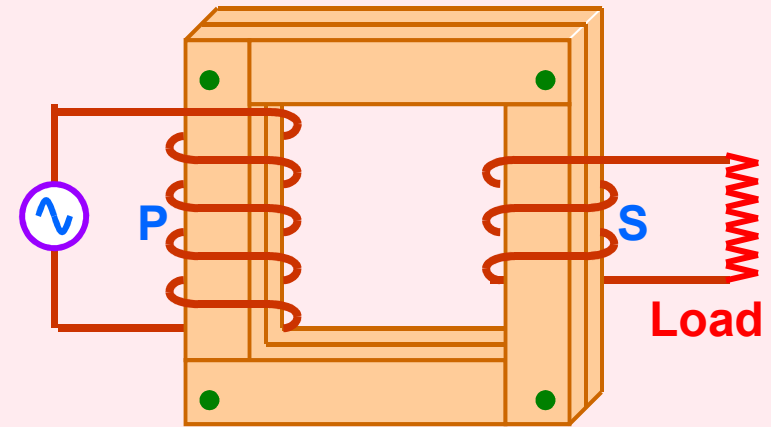

$$N_s < N_p \text{ i.e. } K < 1$$

$$E_s < E_p \text{ \& } I_s > I_p$$

### Energy Losses in a Transformer:

1. **Copper Loss:** Heat is produced due to the resistance of the copper windings of Primary and Secondary coils when current flows through them.

This can be avoided by using thick wires for winding.

2. **Flux Loss:** In actual transformer coupling between Primary and Secondary coil is not perfect. So, a certain amount of magnetic flux is wasted.

Linking can be maximised by winding the coils over one another.

### 3. Iron Losses:

#### a) Eddy Currents Losses:

When a changing magnetic flux is linked with the iron core, eddy currents are set up which in turn produce heat and energy is wasted.

Eddy currents are reduced by using laminated core instead of a solid iron block because in laminated core the eddy currents are confined within the lamination and they do not get added up to produce larger current. In other words their paths are broken instead of continuous ones.

#### b) Hysteresis Loss:

When alternating current is passed, the iron core is magnetised and demagnetised repeatedly over the cycles and some energy is being lost in the process.

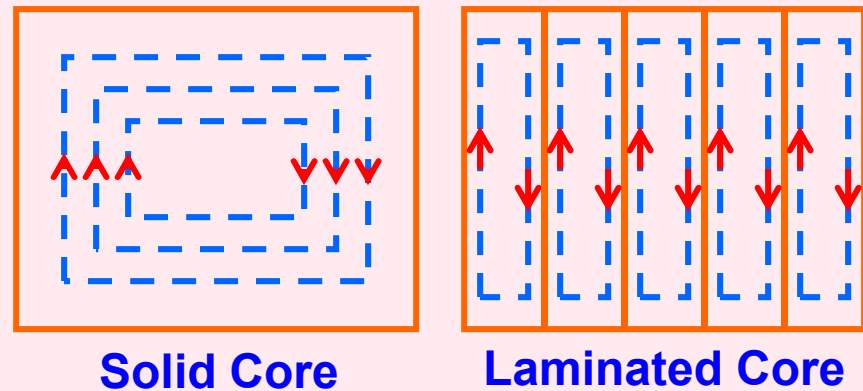

This can be minimised by using suitable material with thin hysteresis loop.

4. **Losses due to vibration of core:** Some electrical energy is lost in the form of mechanical energy due to vibration of the core and humming noise due to magnetostriction effect.

## A.C. Generator:

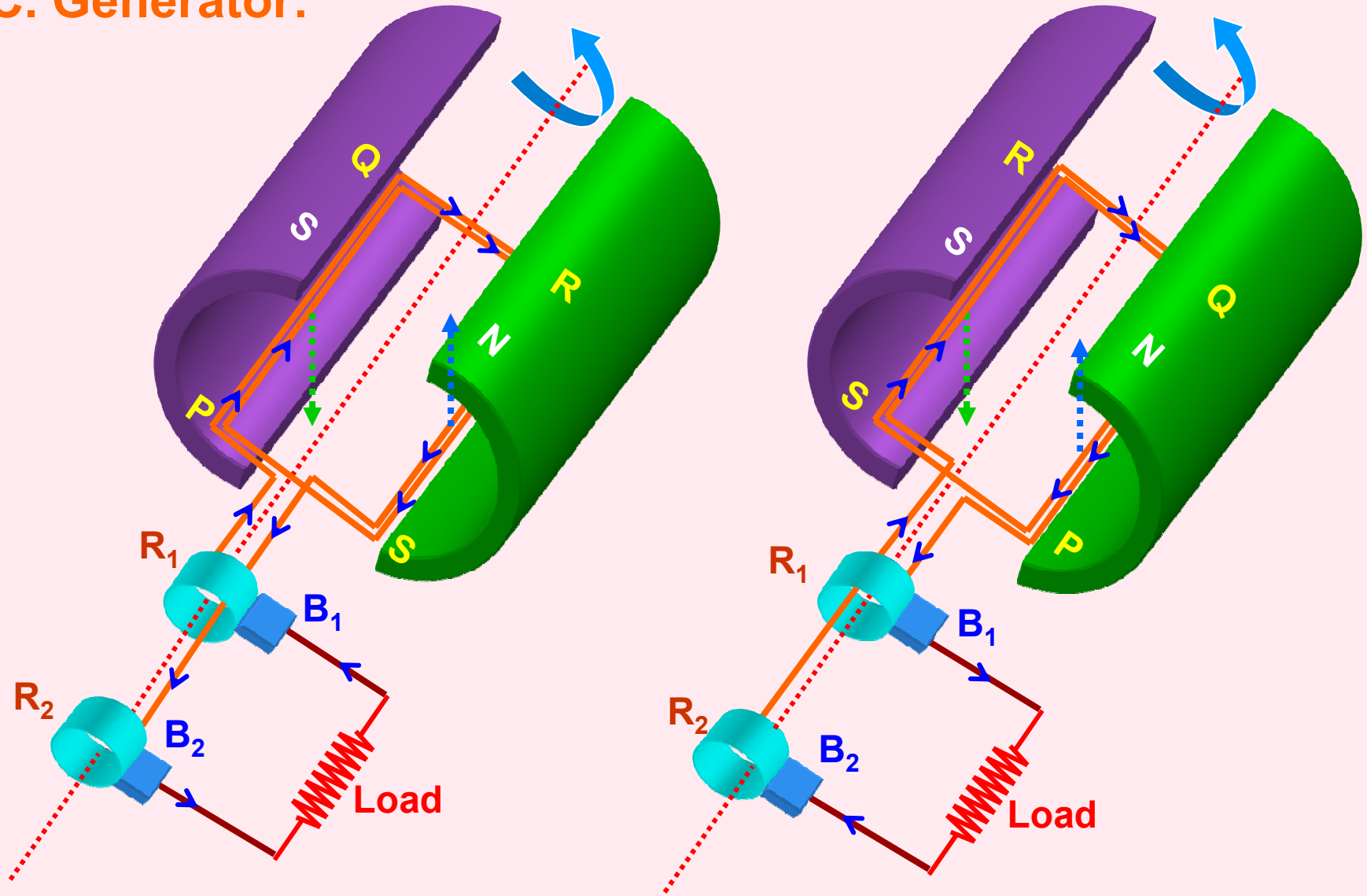

A.C. Generator or A.C. Dynamo or Alternator is a device which converts mechanical energy into alternating current (electrical energy).

## Principle:

A.C. Generator is based on the principle of Electromagnetic Induction.

## Construction:

- (i) Field Magnet with poles N and S
- (ii) Armature (Coil) PQRS
- (iii) Slip Rings ( $R_1$  and  $R_2$ )
- (iv) Brushes ( $B_1$  and  $B_2$ )
- (v) Load

## Working:

Let the armature be rotated in such a way that the arm PQ goes down and RS comes up from the plane of the diagram. Induced emf and hence current is set up in the coil. **By Fleming's Right Hand Rule, the direction of the current is  $PQRSR_2B_2B_1R_1P$ .**

After half the rotation of the coil, the arm PQ comes up and RS goes down into the plane of the diagram. **By Fleming's Right Hand Rule, the direction of the current is  $PR_1B_1B_2R_2SRQP$ .**

**If one way of current is taken +ve, then the reverse current is taken -ve.**

**Therefore the current is said to be alternating and the corresponding wave is sinusoidal.**

## Theory:

$$\Phi = N B A \cos \theta$$

At time  $t$ , with angular velocity  $\omega$ ,

$\theta = \omega t$  (at  $t = 0$ , loop is assumed to be perpendicular to the magnetic field and  $\theta = 0^\circ$ )

$$\therefore \Phi = N B A \cos \omega t$$

Differentiating w.r.t.  $t$ ,

$$d\Phi / dt = - N B A \omega \sin \omega t$$

$$E = - d\Phi / dt$$

$$E = N B A \omega \sin \omega t$$

$$E = E_0 \sin \omega t \quad (\text{where } E_0 = N B A \omega)$$

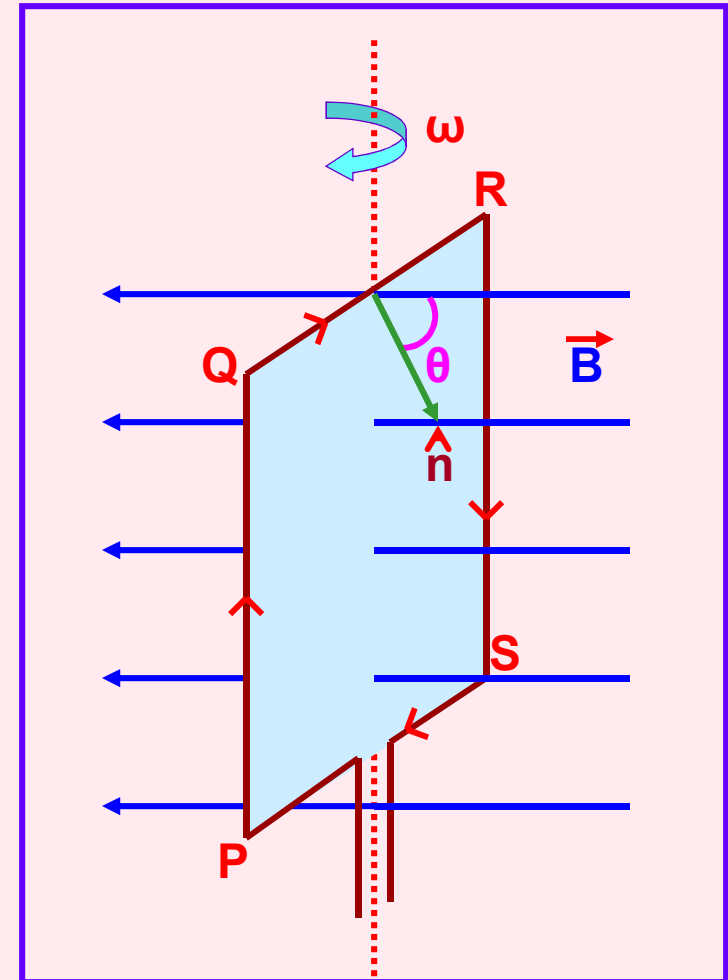
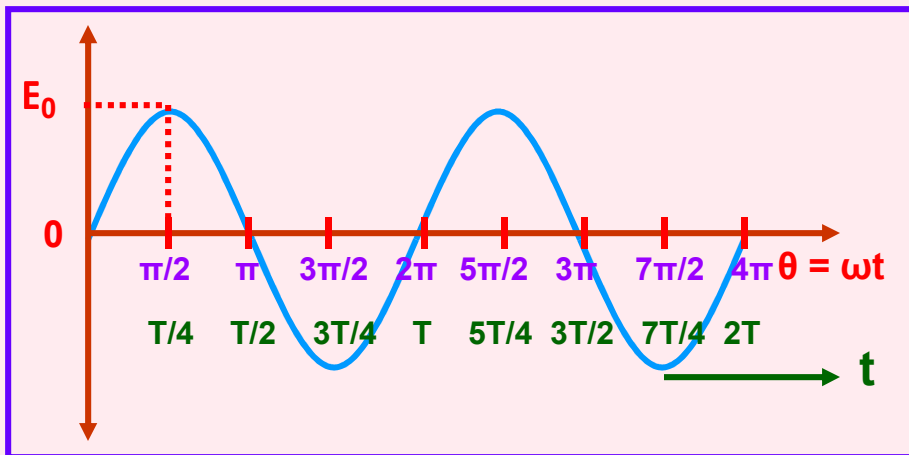

End of Alternating Currents