

The Dielectric Multiplier

Unlocking the physics of capacitance and molecular polarization.

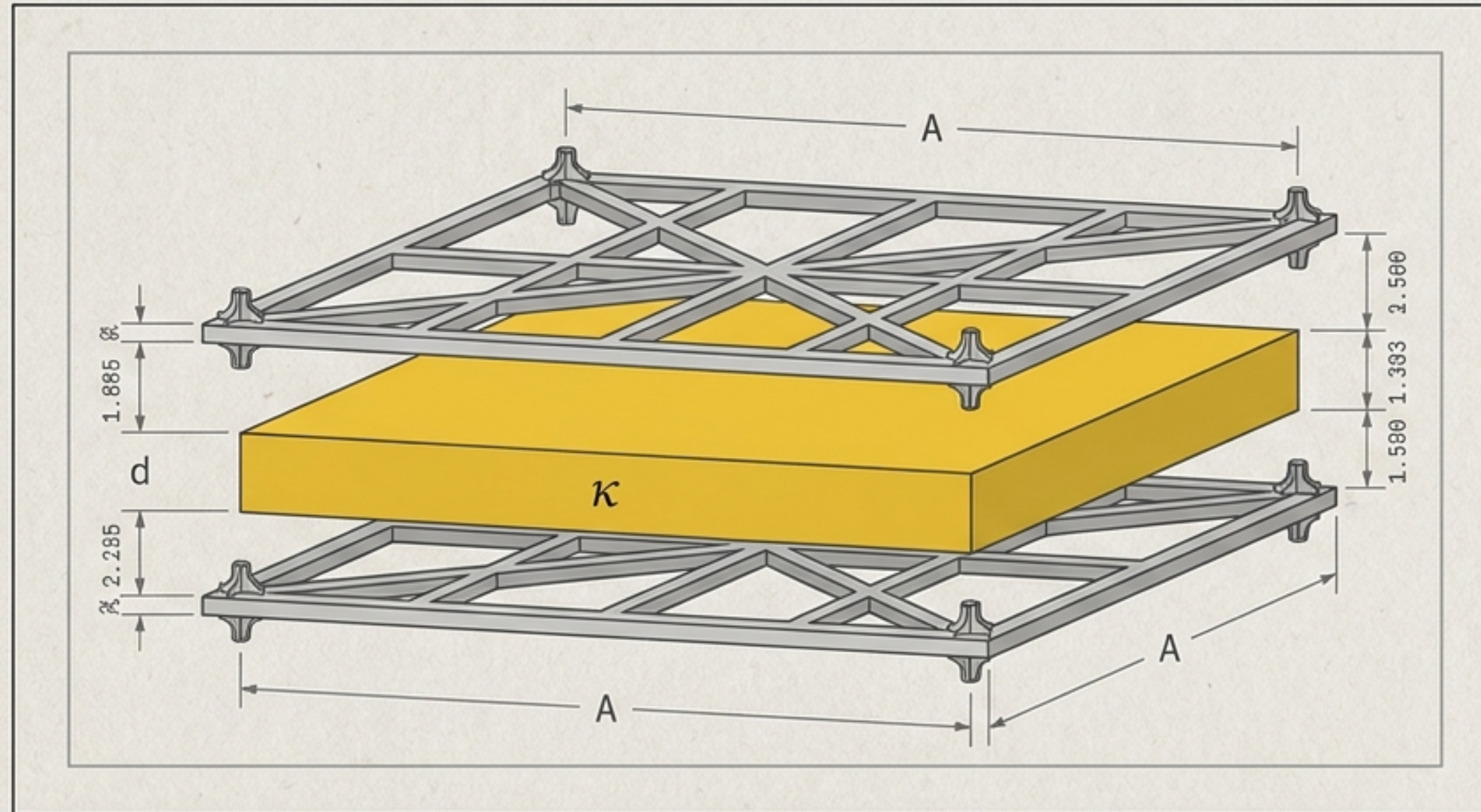

Insert an insulator. Multiply the capacitance.

Connect a capacitor to a battery. Insert a thin insulating material between the plates without changing their size or distance. Suddenly, the capacitance becomes four, five, or even ten times larger.

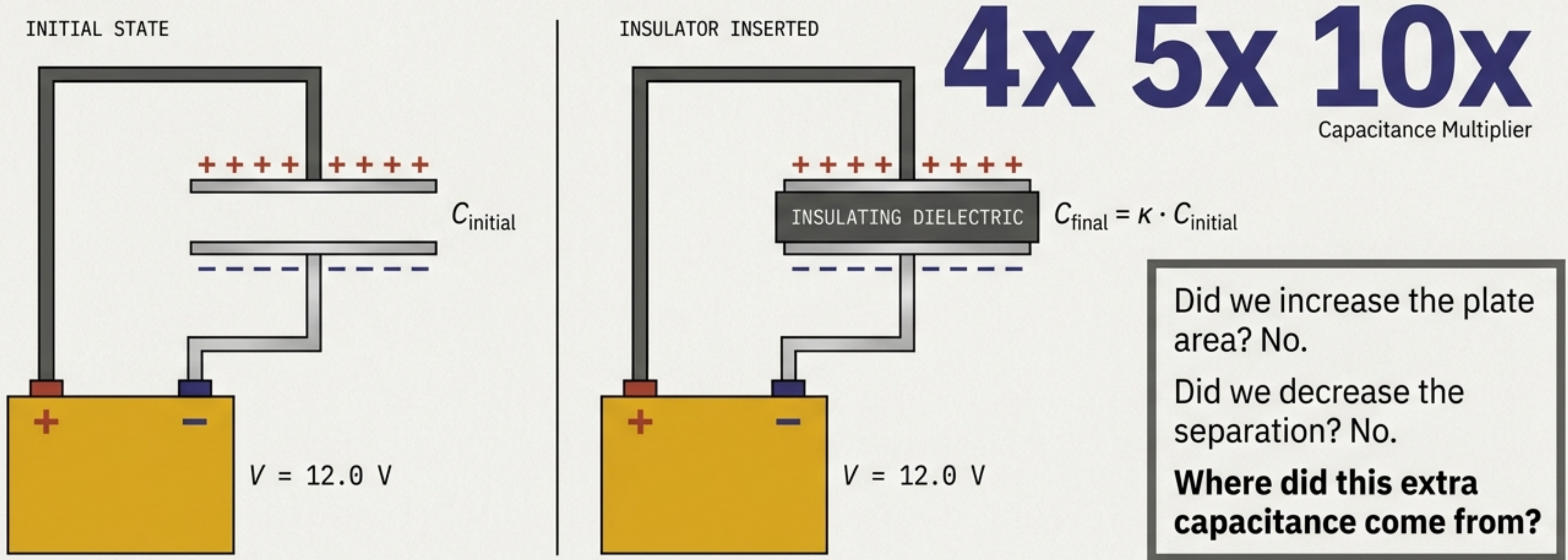

Capacitance measures the ability to store charge per volt applied.

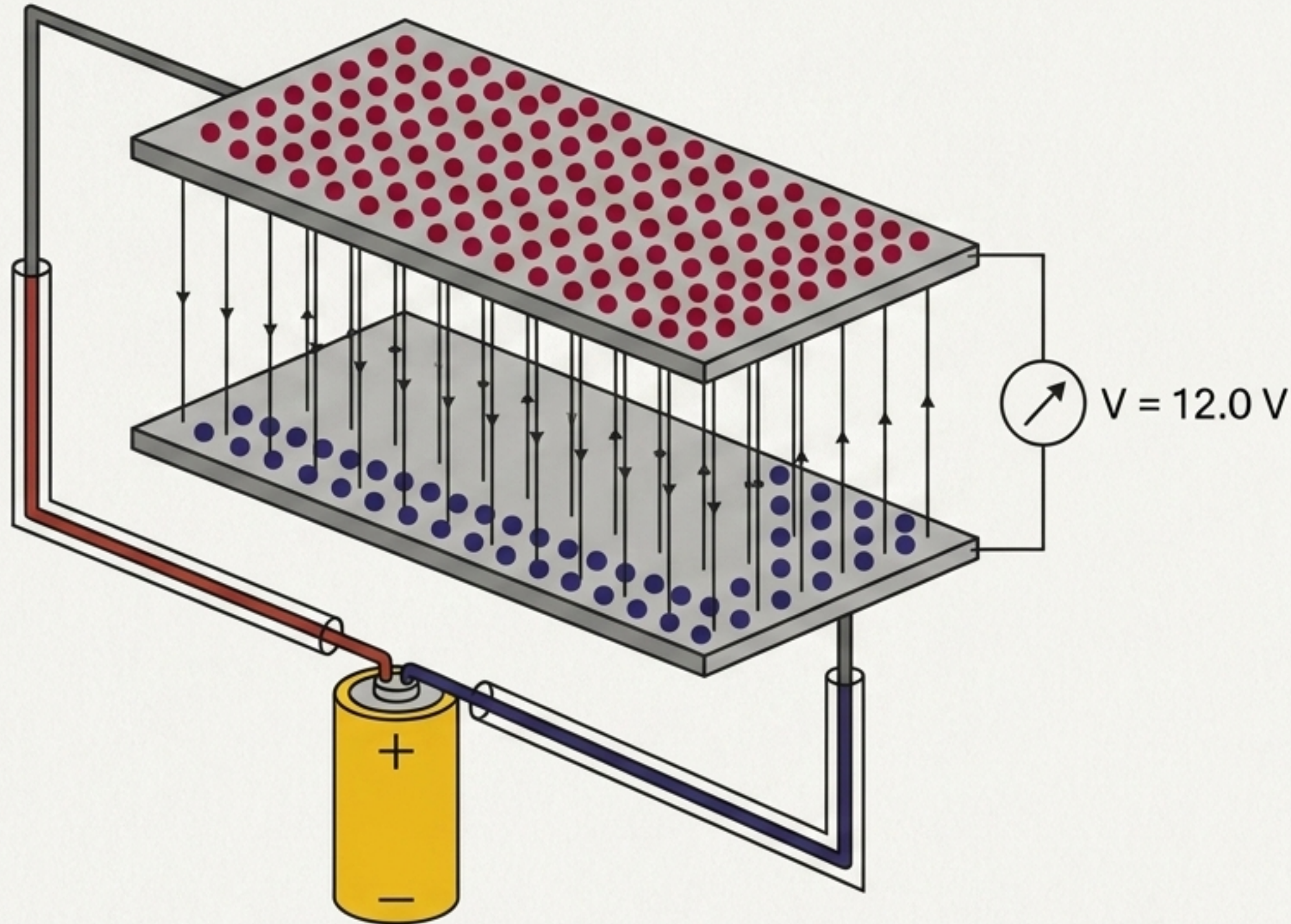

$$C = Q / V$$

Q = charge stored

V = potential difference

A capacitor storing 20 microcoulombs on a 100V battery has higher capacitance than one storing 2 microcoulombs. It stores more charge for the same voltage.

For an **air-filled capacitor**, geometry alone decides capacitance.

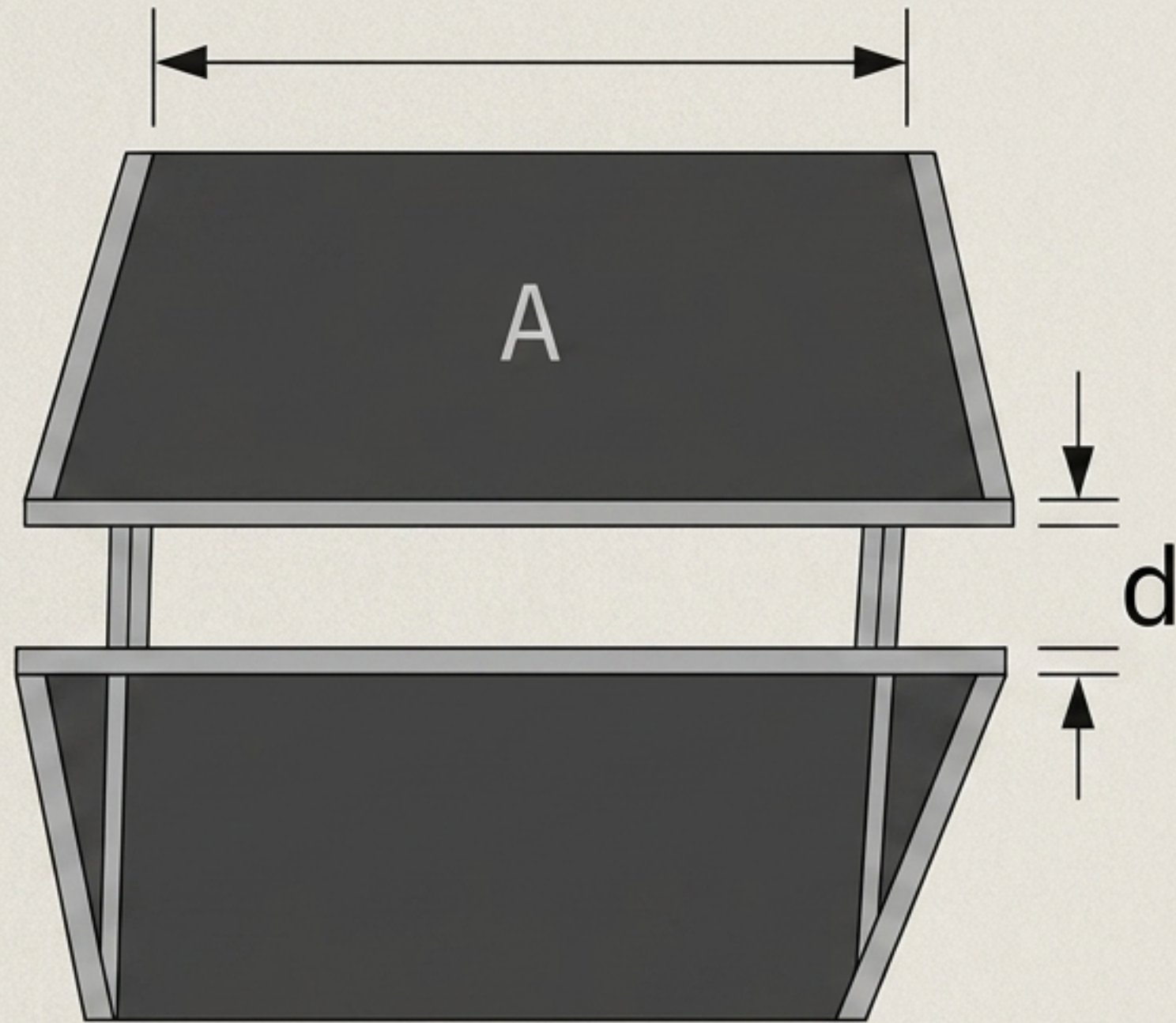

$$C = \frac{\epsilon_0 A}{d}$$

A: Area of the plates.

d: Distance between plates.

ϵ_0 : The medium (Air/Vacuum).

Notice what is missing.

There is no charge (Q) in this formula.

There is no voltage (V) in this formula.

Geometry decides the baseline.

The electric field transforms random molecules into tiny electric dipoles.

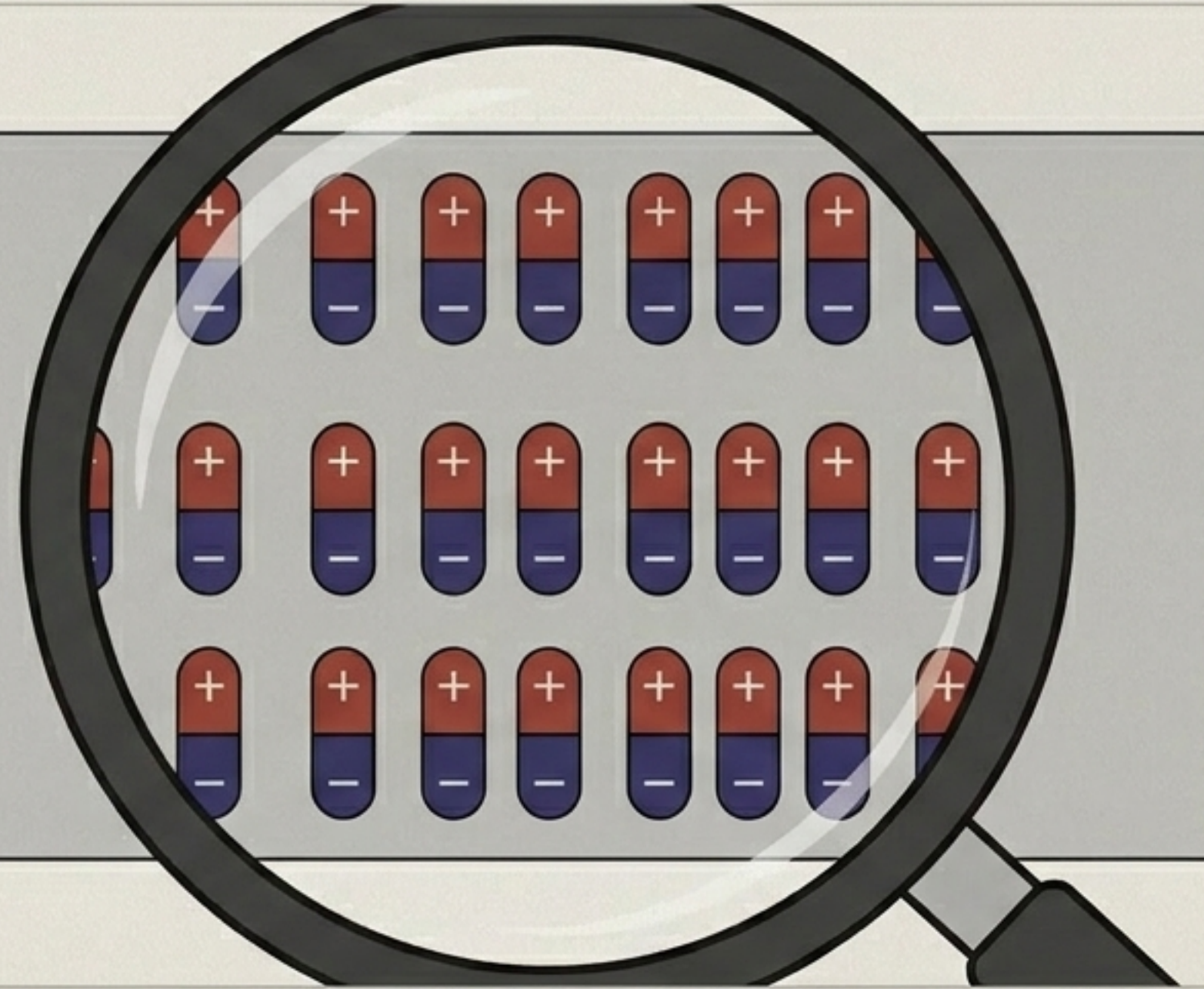
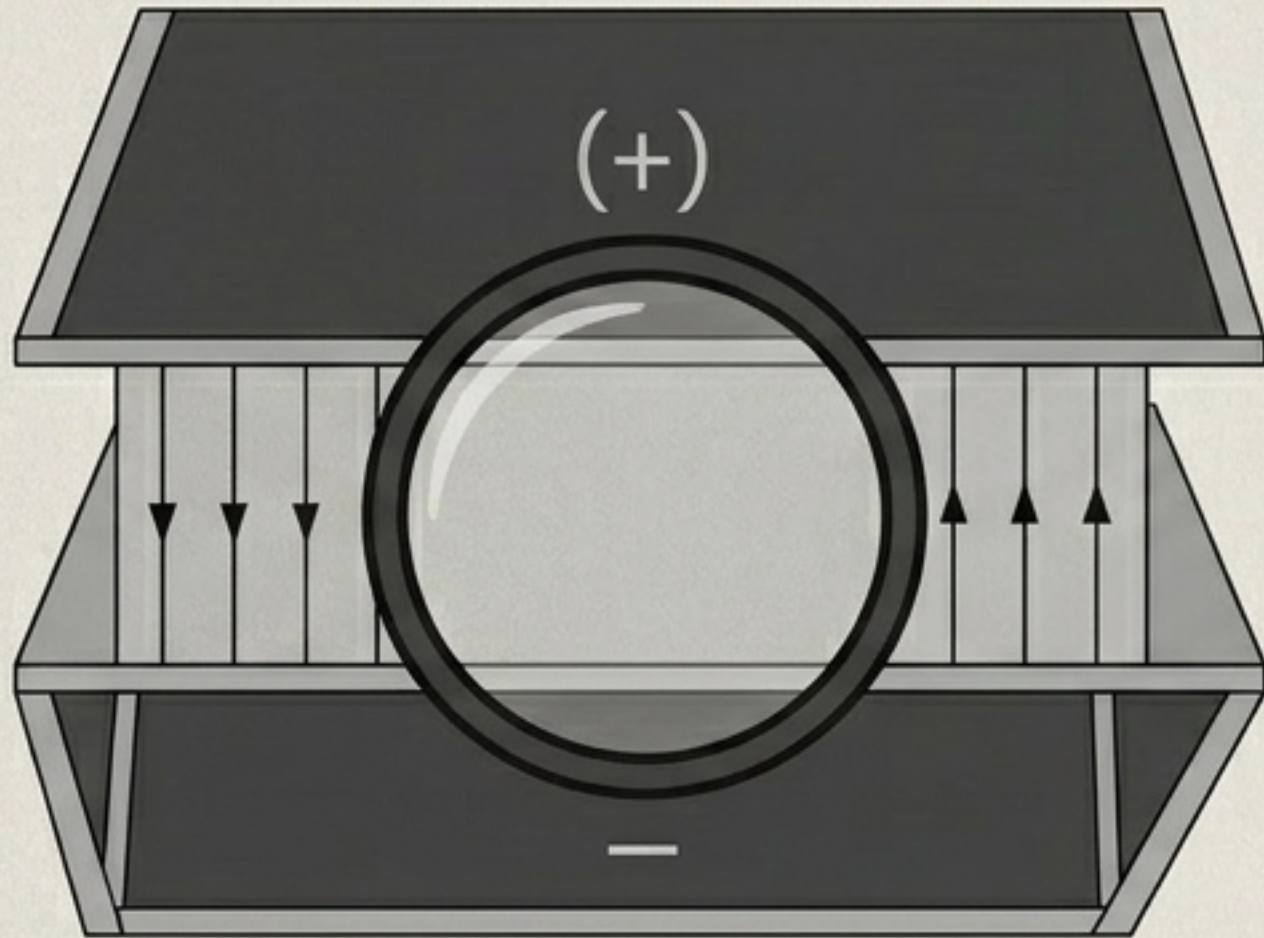

A dielectric is an insulating material. Normally, its internal charges are randomly arranged. But placed between charged plates, the electric field acts on every molecule, causing a small separation of charges. This small separation is called **polarization**.

The polarized molecules fight back, shrinking the net electric field.

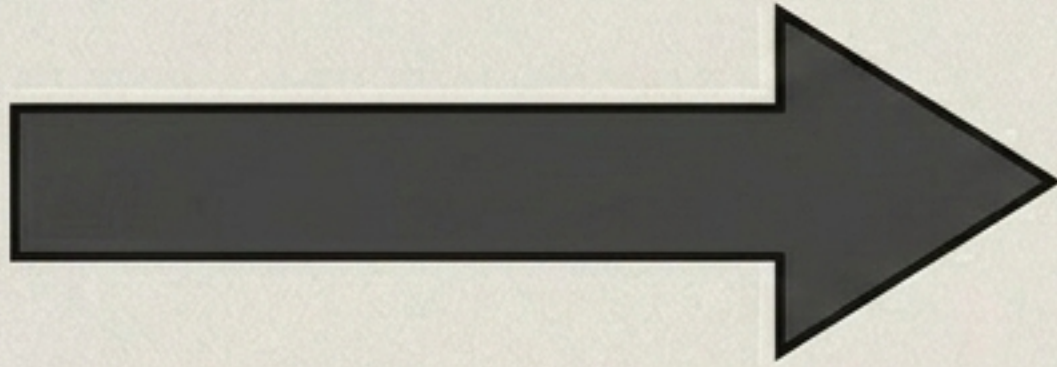

Original
Electric
Field

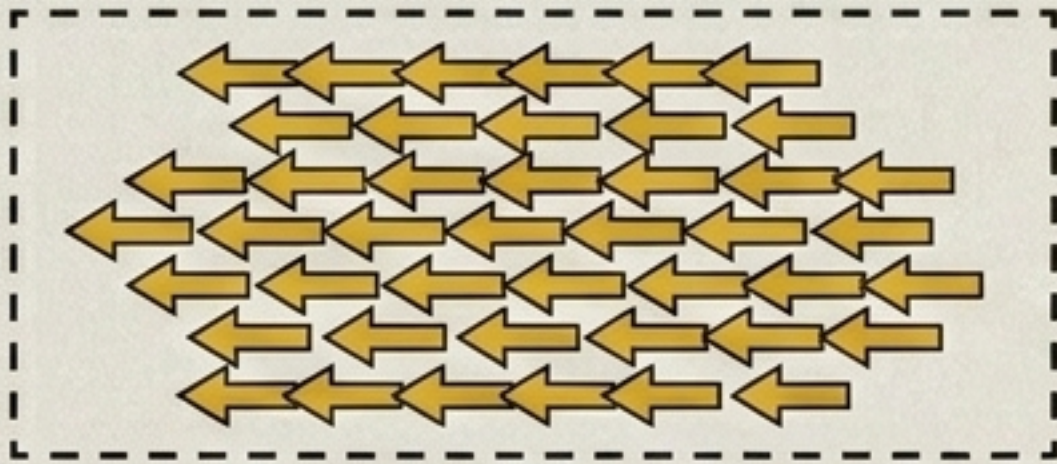

Induced
Electric
Field

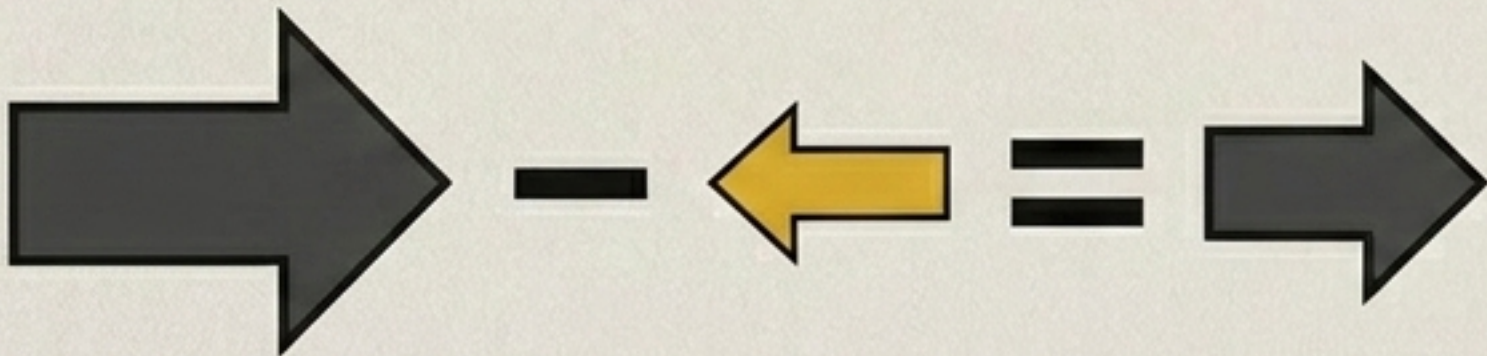

Net
Electric
Field

The polarized molecules create their own electric field.

Because this induced field opposes the original field, the net electric field becomes smaller.

Smaller electric field = smaller potential difference between the plates.

The battery compensates to restore the lost voltage.

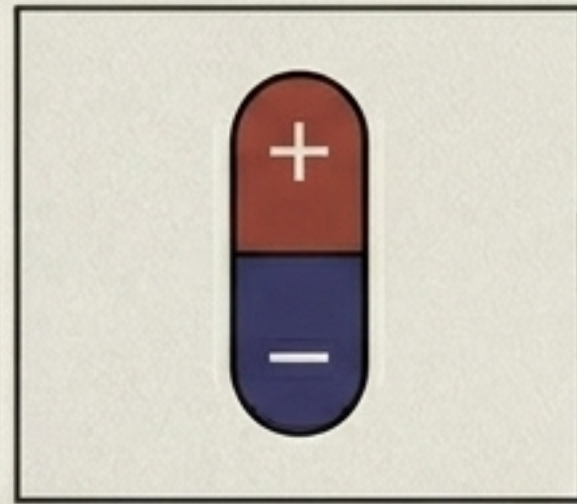

1. Molecules polarize.

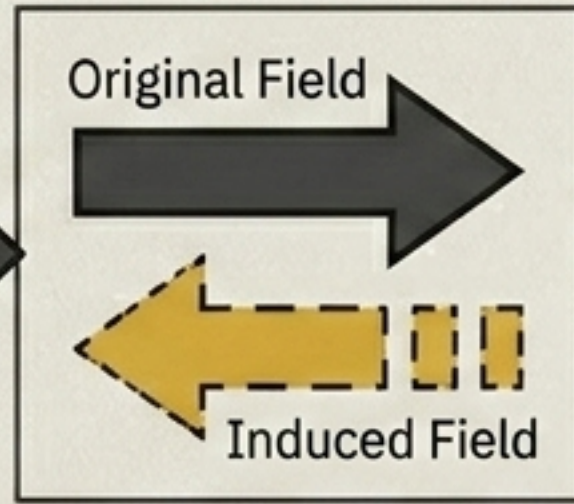

2. Induced field opposes original field.

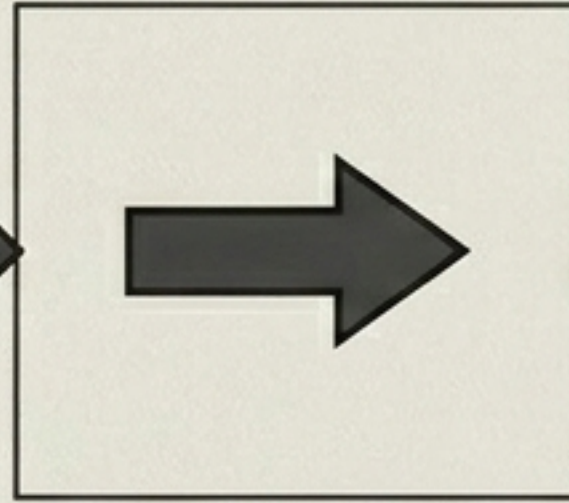

3. Net electric field drops.

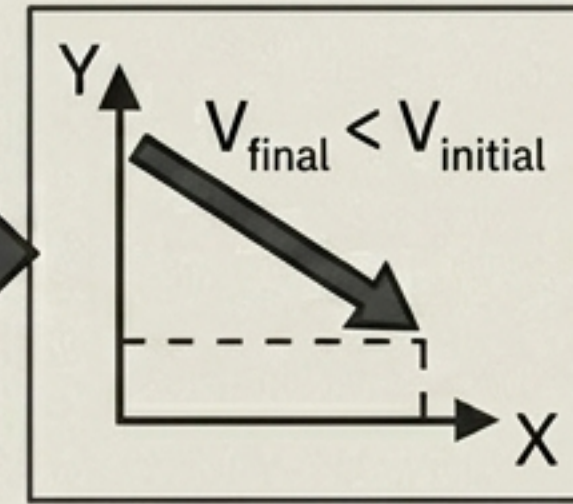

4. Potential difference (Voltage) drops.

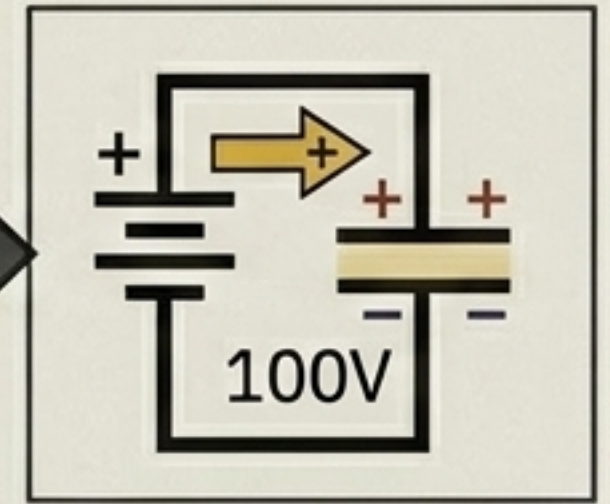

5. The connected battery pushes more charge onto the plates to restore the 100V baseline.

More charge stored at the same voltage
($C = Q/V$) = **Higher Capacitance.**
That is the real physics.

The final formula, demystified.

$$C = \underbrace{K}_{\text{Multiplier}} \left. \frac{\epsilon_0 A}{d} \right\}_{\text{Canvas}}$$

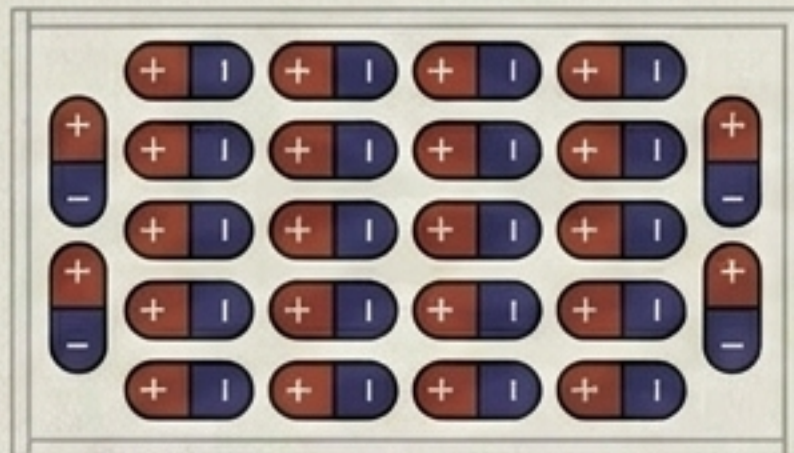

The Multiplier. A larger **K** means the material polarizes more effectively. **If $K=6$,** capacitance becomes **six times larger.**

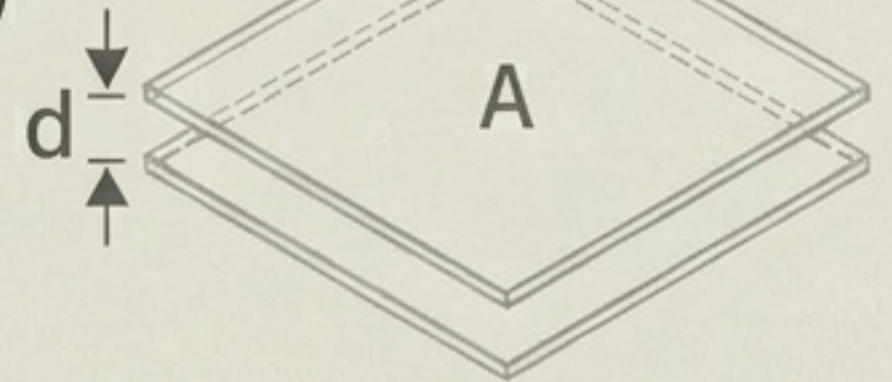

The Canvas. Geometry dictates the baseline capacity.

Case Study: Measuring the Dielectric Boost.

An air-filled parallel plate capacitor is completely filled with a dielectric material ($K = 4$).

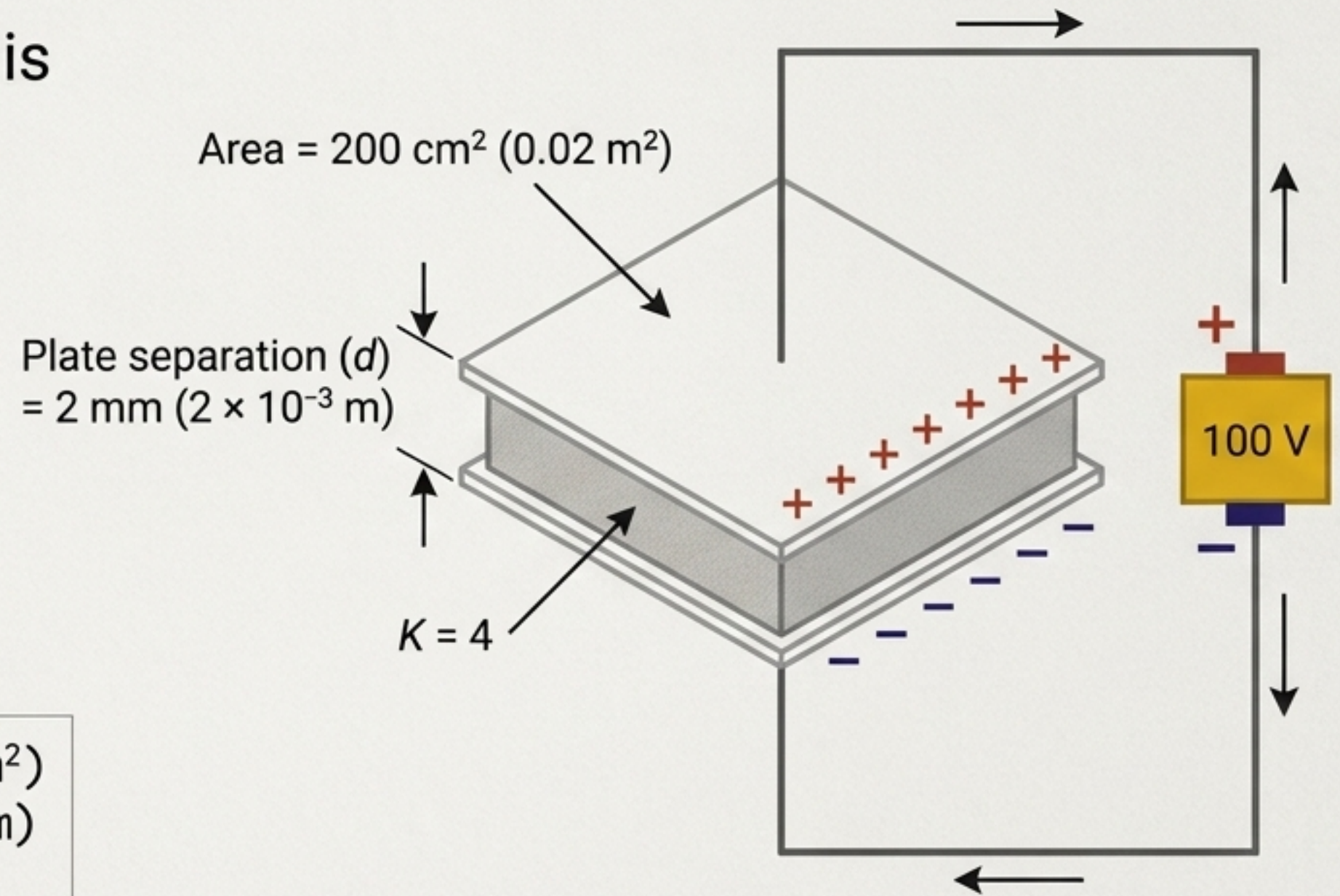

Area	= $200 \text{ cm}^2 (0.02 \text{ m}^2)$
Plate separation (d)	= $2 \text{ mm} (2 \times 10^{-3} \text{ m})$
Battery voltage (V)	= 100 V
Dielectric constant (K)	= 4

The physical impact of $K=4$ across all dimensions.

	Air-Filled ($K=1$)	Dielectric-Filled ($K=4$)
Capacitance (C)	$8.85 \times 10^{-11} \text{ F}$	$3.54 \times 10^{-10} \text{ F}$
Charge (Q)	$8.85 \times 10^{-9} \text{ C}$	$3.54 \times 10^{-8} \text{ C}$
Stored Energy (U)	$4.425 \times 10^{-7} \text{ J}$	$1.77 \times 10^{-6} \text{ J}$

4x Boost

Initial $C = \epsilon_0 A/d$. Final $C' = KC$. Charge $Q = CV$. Energy $U = \frac{1}{2}CV^2$.

The extra energy comes from the battery working harder.

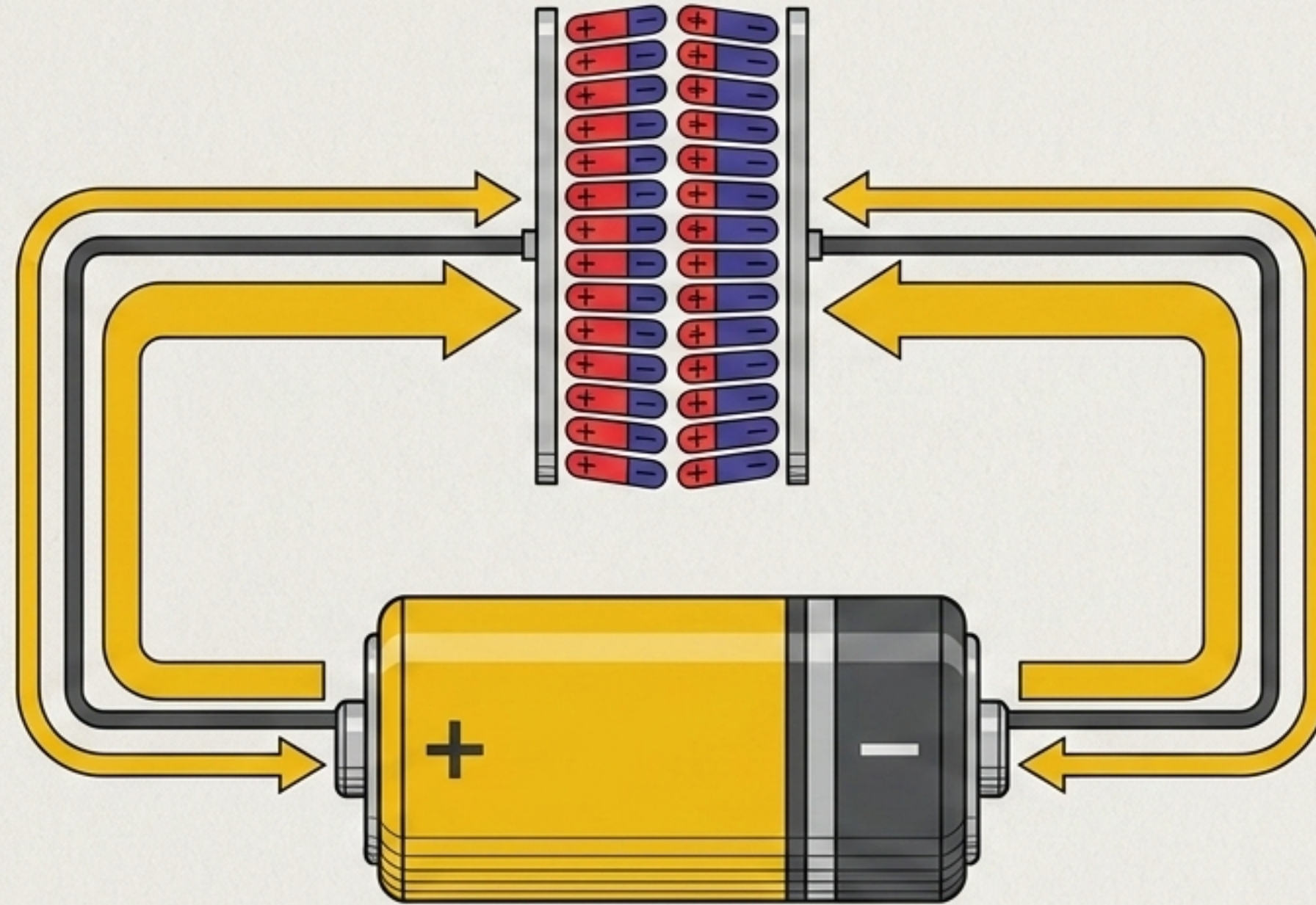

Both charge and stored energy increase. The extra energy doesn't appear out of nowhere—the battery must supply additional charge to maintain constant voltage against the resistance of the induced electric field. The dielectric resists; the battery overcomes.

$$C = \frac{\epsilon_0 \cdot V}{2 \cdot d}$$

$$Q_c = h + I_T \frac{1}{d \cdot l}$$

$$\left(-\frac{E_c}{R^2} + \frac{l}{r} \right)$$

**“Most students memorize formulas.
Great students understand concepts.”**

Today you learned not only that capacitance increases with a dielectric, but why it increases. Once you understand the physics, every related numerical becomes much easier.

$$U_G = \epsilon_0 \frac{I}{d} \cdot C + \pi d$$

$$U = \frac{A^L (\mu_r)}{z \cdot d}$$

$$I = \epsilon_0 \sum_{i=1}^m (\Delta I - \gamma_i / \rho I_i)^2$$