

**CAMBRIDGE SCHOOL SRINIVASPURI**  
**MID TERM EXAMINATION - 2023-24**  
**BIOLOGY (044)**  
**CLASS XII**

**TIME: 3 hr.**

**M.M. 70**

**General Instructions:**

- (i) All the questions are compulsory.
- (ii) The question paper has five sections and 33 questions
- (iii) Section A consists of 16 multiple choice questions carrying 1 mark each.
- (iv) Section B consists of 5 short answer questions carrying 2 marks each.
- (v) Section C consists of 7 short answer questions carrying 3 marks each.
- (vi) Section D consists of 2 case-based questions carrying 4 marks each.
- (vii) Section E consists of 3 long answer questions carrying 5 marks each.
- (viii) There is no overall choice. However, internal choices have been provided in some questions.  
A student has to attempt only one of the alternatives in such questions.
- (ix) Wherever necessary, neat and properly labeled diagrams should be drawn.

SECTION - A																						
1	The intine of pollen grain is made of: a) Sporopollenin b) Pectin c) Sucrose d) Strong acids	1																				
2	The white kernel in coconut is: a) Free-nuclear endosperm b) PEN c) Seed d) Cellular endosperm	1																				
3	Below is a chart of the different bases each organism has. Along the top of the chart, you will find the base pair and the numbers underneath represent the percentages of those found in the organisms. <table border="1" style="width: 100%; margin: 10px 0;"> <thead> <tr> <th>Organism</th> <th>Adenine (A)</th> <th>Thymine (T)</th> <th>Guanine (G)</th> <th>Cytosine (C)</th> </tr> </thead> <tbody> <tr> <td>Escherichia coli</td> <td>26.0</td> <td>23.9</td> <td></td> <td>25.2</td> </tr> <tr> <td>Mouse</td> <td>29.2</td> <td>29.4</td> <td></td> <td>19.7</td> </tr> <tr> <td>Human</td> <td>30.7</td> <td>31.2</td> <td></td> <td>18.8</td> </tr> </tbody> </table> The correct values for the amount of Guanine present in Escherichia coli, Mouse and Humans respectively is: a) 24.9 ,21.7 ,19.3 b) 21.7 ,19.3, 24.9 c) 19.3,21.7, 24.9 d) 19.3, 24.9, 21.7	Organism	Adenine (A)	Thymine (T)	Guanine (G)	Cytosine (C)	Escherichia coli	26.0	23.9		25.2	Mouse	29.2	29.4		19.7	Human	30.7	31.2		18.8	1
Organism	Adenine (A)	Thymine (T)	Guanine (G)	Cytosine (C)																		
Escherichia coli	26.0	23.9		25.2																		
Mouse	29.2	29.4		19.7																		
Human	30.7	31.2		18.8																		
4	In human beings, where genotype <b>AABBCC</b> represents dark skin colour, <b>aabbcc</b> represents light skin colour and <b>AaBbCc</b> represents intermediate skin colour; the pattern of genetic inheritance can be termed as: a) Pleiotropy and codominance b) Pleiotropy and incomplete dominance c) Polygenic and qualitative inheritance	1																				

	d) Polygenic and quantitative inheritance	
5	<p>If a genetic disease is transferred from a phenotypically normal but carrier female to only some of the progeny, the disease is</p> <ol style="list-style-type: none"> <li>autosomal dominant</li> <li>autosomal recessive</li> <li>sex-linked dominant</li> <li>sex-linked recessive</li> </ol>	
6	<p>Which of the following statements is correct:</p> <ol style="list-style-type: none"> <li>Euchromatin is transcriptionally active.</li> <li>Heterochromatin is transcriptionally active.</li> <li>In a typical nucleus some region of chromatin is tightly packed and called euchromatin.</li> <li>In a typical nucleus some region of chromatin is loosely packed and called heterochromatin.</li> </ol>	
7	<p>What is the smallest part of a DNA molecule that can be changed by a point mutation?</p> <ol style="list-style-type: none"> <li>Oligonucleotide</li> <li>Codon</li> <li>Gene</li> <li>Nucleotide</li> </ol>	
8	<p>Pedigree A</p> <p>Pedigree B</p> <p>Pedigree C</p> <p>Pedigree D</p> <p>Pedigree E</p> <p>Indicate the pattern of inheritance observed for <b>pedigree B</b>.</p> <ol style="list-style-type: none"> <li>Autosomal dominant</li> <li>Autosomal recessive</li> <li>Sex linked dominant</li> <li>Sex linked recessive</li> </ol>	
9	<p>Genetically engineered microbes used in oil spill bioremediation are a species of?</p> <p>(a) Pseudomonas (b) Trichoderma (c) Xanthomonas (d) Bacillus</p>	

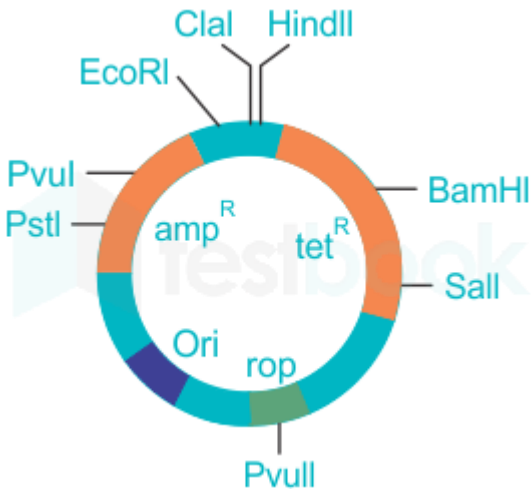
10	How many bases does the sequence which identifies the restriction enzymes contain? a) 1    b) 4    c) 6    d) 12	1
11	Crystals of Bt toxin produced by some bacteria do not kill the bacteria themselves because; a) Bacteria are resistant to the toxin b) Toxin is immature c) Toxin is inactive d) Bacteria enclose toxin in a special sac.	1
12	 <p>Selectable marker in the above is: a) Eco RI b) rop c) Ori d) amp<sup>R</sup></p>	1
	Q 13 to 16 are Assertion - Reasoning based questions. These consist of two statements – Assertion (A) and Reason (R). Answer these questions selecting the appropriate option given below: (a) Both A and R are true and R is the correct explanation of A. (b) Both A and R are true and R is not the correct explanation of A. (c) A is true but R is false. (d) A is False but R is true.	
13	Assertion: Restriction enzymes recognize palindromic sequence. Reason: Palindromic sequences read same in both directions of the two strands.	1
14	Assertion: Pollen mother cells (PMCs) are the first male gametophytic cells. Reason: Each PMC gives rise to two pollens.	1
15	Assertion: The hnRNA in humans has exons and introns. Reason: The primary transcript produced in eukaryotes is translated without undergoing any modification or processing.	1
16	Assertion: The operon is a unit of gene expression. Reason: Lac operon in E. coli is an inducible control.	1
<b>SECTION – B</b>		
17	Describe the structure of seminiferous tubules.	2

18

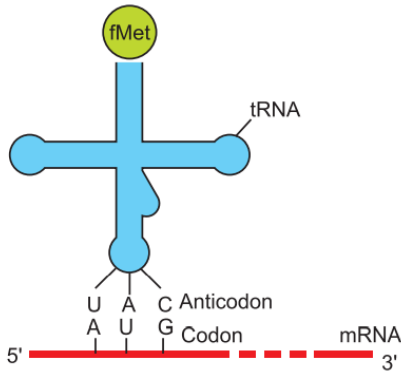

- (i) Why is charging of tRNA essential in translation?  
 (ii) Where does peptide bond formation occur in a bacterial ribosome?

2

19

Study the diagram showing replication of HIV in humans and answer the following questions accordingly.

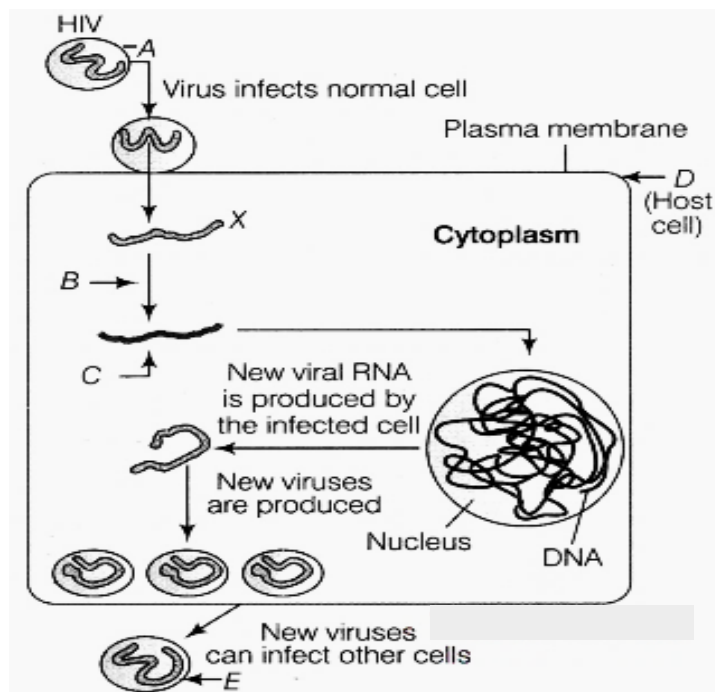

- (i) Name the enzyme B acting on X to produce molecule C. Name C.  
 (ii) Name the two different cells the new viruses E subsequently attack.

2

20

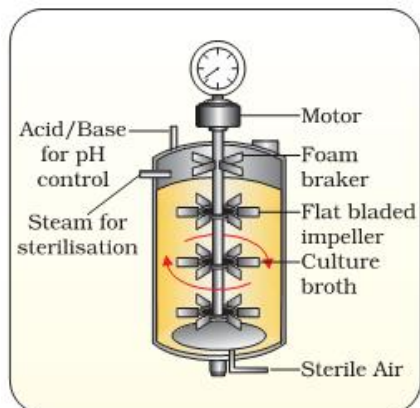

2

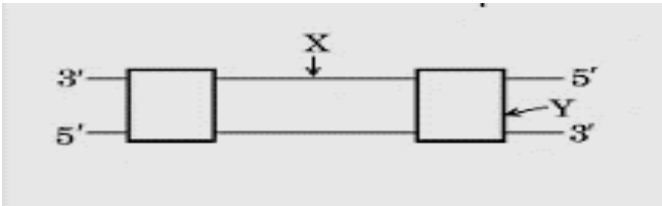
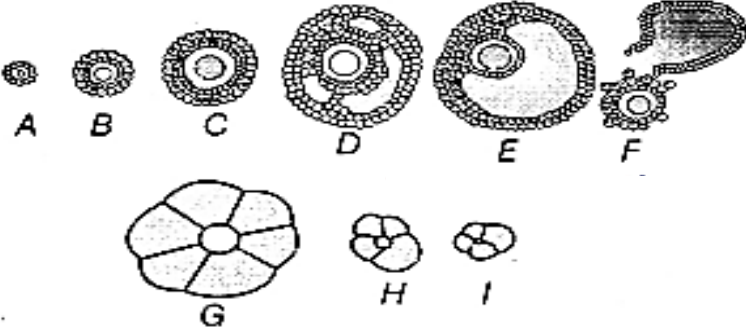
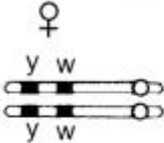
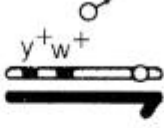
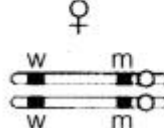
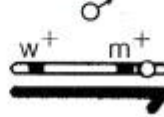
	Identify the figure shown above. State any two advantages of such a device.	
21	<p>What do <b>X</b> and <b>Y</b> represent in the transcription unit of the DNA molecule shown? What lies to the upstream of <b>X</b>? Which enzyme binds at that site?</p> 	2
<b>SECTION - C</b>		
22	<p>The following is the illustration of the sequence of ovarian events <b>A-I</b> in a human female.</p>  <p>(i) Identify the figure that illustrates corpus luteum and name the pituitary hormone that influences its formation.</p> <p>(ii) Specify the endocrine function of corpus luteum. How does it influence the uterus? Why is it essential?</p>	3
23	What is apomixis and what is its importance? Why is apple called a false fruit?	3
24	How does the estrogen-progesterone combination act as a contraceptive measure? Female gametes are transferred to the fallopian tube in the GIFT procedure. Is it possible to transfer the gametes to the uterus? Why?	3
25	<p>Study the figures given below and answer the question.</p> <p style="text-align: center;"><b>Cross A</b></p> <div style="display: flex; justify-content: space-around;"> <div style="text-align: center;"> <p>♀</p>  <p>Yellow, white</p> </div> <div style="text-align: center;"> <p>♂</p>  <p>Wild type</p> </div> </div> <p style="text-align: center;"><b>Cross B</b></p> <div style="display: flex; justify-content: space-around;"> <div style="text-align: center;"> <p>♀</p>  <p>White, miniature</p> </div> <div style="text-align: center;"> <p>♂</p>  <p>Wild type (Parental)</p> </div> </div> <p>Identify in which of the crosses, the strength of linkage between the genes is higher. Give reasons in support of your answer. State one difference between Polygenic inheritance and pleiotropy.</p>	3

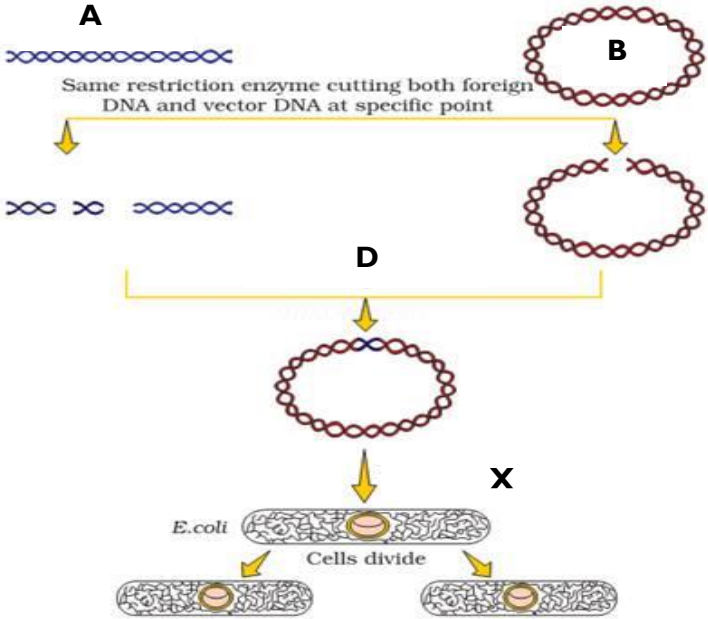
26	Name the source of cyclosporin-A. How does this bioactive molecule function in our body? Name the source of statin and state its action on the human body.	3
27	<p>Observe the given sequence of nitrogenous bases on a DNA fragment and answer the following question</p> <p>5' – CAGAATTCTTA – 3' 3' – GTCTTAAGAAT – 5'</p> <p>(a) Name a restriction enzyme which can recognise this DNA sequence. (b) Write the sequence after digestion. (c) Why are the ends generated after digestion called sticky ends?</p> <p style="text-align: center;"><b>OR</b></p> <div style="text-align: center;">  <p>The diagram illustrates the process of creating a recombinant plasmid. It starts with a linear DNA fragment (A) and a circular plasmid (B). Both are cut with the same restriction enzyme at a specific point, creating sticky ends. The resulting DNA fragments (D) are then joined together. The recombinant plasmid (X) is introduced into E. coli cells, which then divide.</p> </div> <p>a) Identify A and B in the figure shown above. b) Which enzyme is required at D and why? c) Which process is essential at X?</p>	3
28	Explain the role of Ti plasmids in biotechnology. What are 'BAC' and 'YAC'. What is the purpose for which they are used?	3
<p><b>SECTION – D</b></p> <p><b>The following questions are case-based questions. Each question has an internal choice and carries 4 (1+1+2) marks each. Read the passage carefully and answer the questions that follow.</b></p>		

29

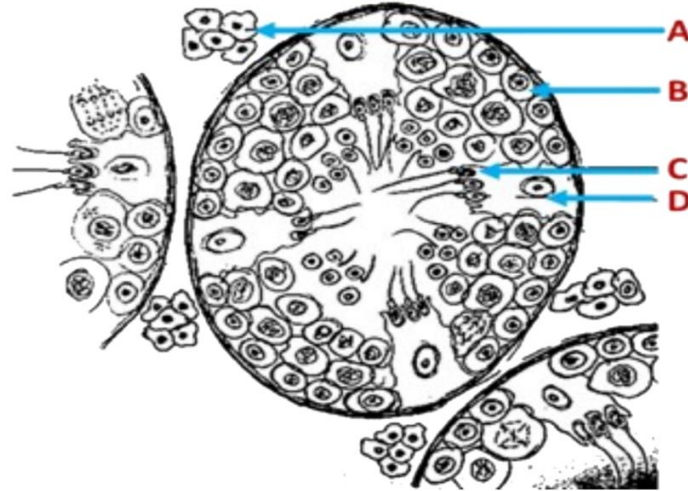

4

- (a) Identify A and B in the figure above.
- (b) What is the role of D?
- (c) Describe the formation of C from B.

OR

- (c) State the difference between spermatozoa and spermatids.

30

The figure shown below is the stages

4

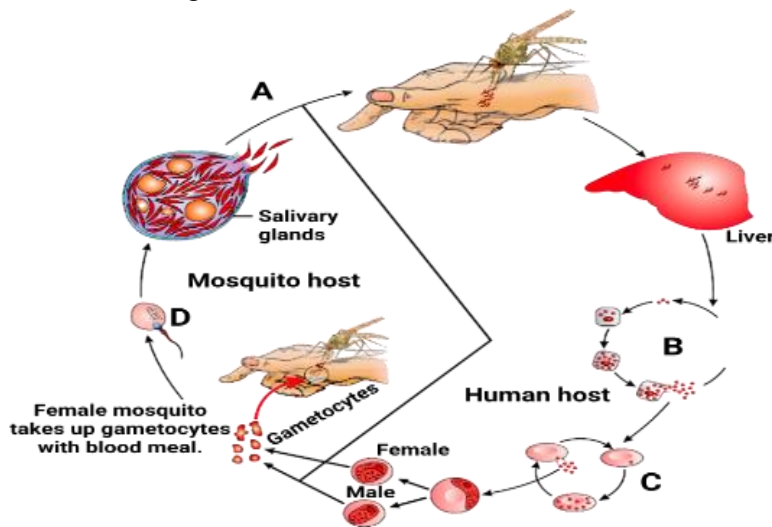

- (a) Identify the process taking place in B
- (b) Name any two species of Plasmodium that cause malaria. Which out of these causes malignant form of the disease?
- (c) What happens at C? Which chemical is released at this stage?

OR

- (c) Which is the mature infective stage of the parasite? How does it reach the human body?

**SECTION - E**

31

Study the given portion of double stranded polynucleotide chain carefully. Identify a, b, c and the 5' end of the chain.

5

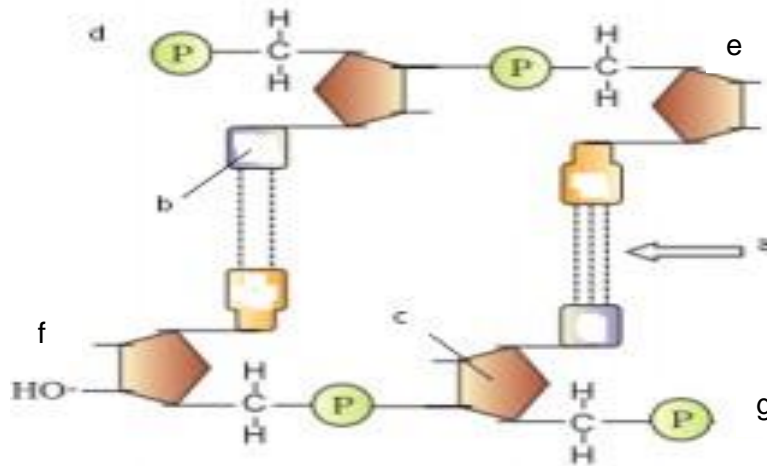

List the salient features of DNA double helix structures.

OR

Observe following diagram and give the answer.

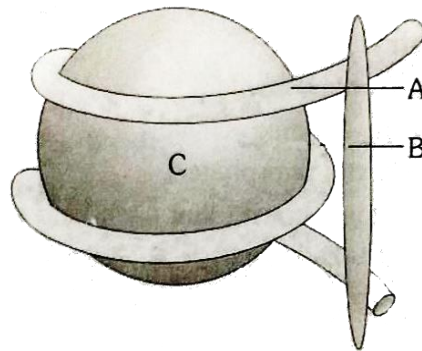

(a) Identify the structure in the diagram above. What are histone proteins?

(b) DNA is far longer than the dimensions of atypical mammalian cell nucleus, so how is such a long polymer packaged in a cell?

32

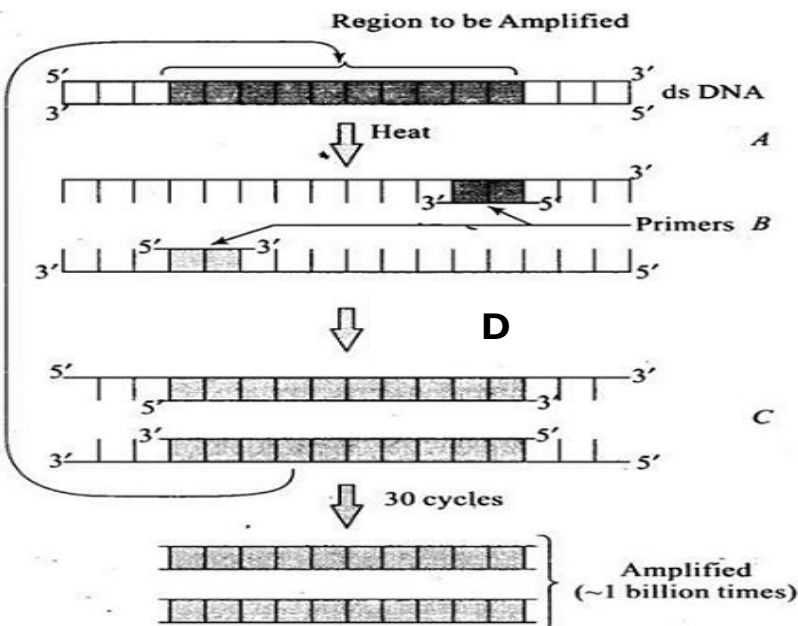

(a) In the figure shown above which process of amplification is shown? What is the advantage of using this process?

5

- (b) Identify the steps represented by A, B and C in the figure.  
 (c) Which enzyme is used at D? Name the organism from which it is derived?

**OR**

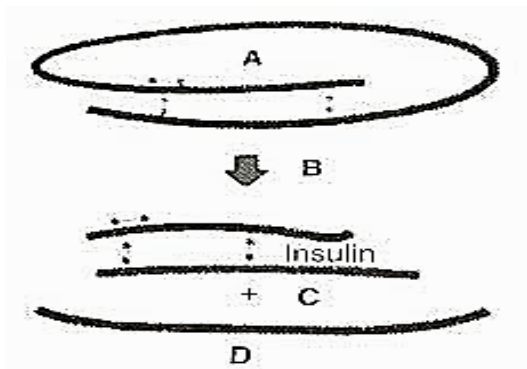

- (a) Identify the process shown in the figure above.  
 (b) Identify A, B, C and D in the figure.  
 (c) How is human insulin prepared by Eli Lilly?

33 What are Cry proteins? Name an organism that produces it. How has man exploited this protein to his benefit?

**OR**

What is gene therapy? Illustrate using the example adenosine deaminase deficiency.

5