

1 The ray diagram shows the image of an object formed by a converging lens.

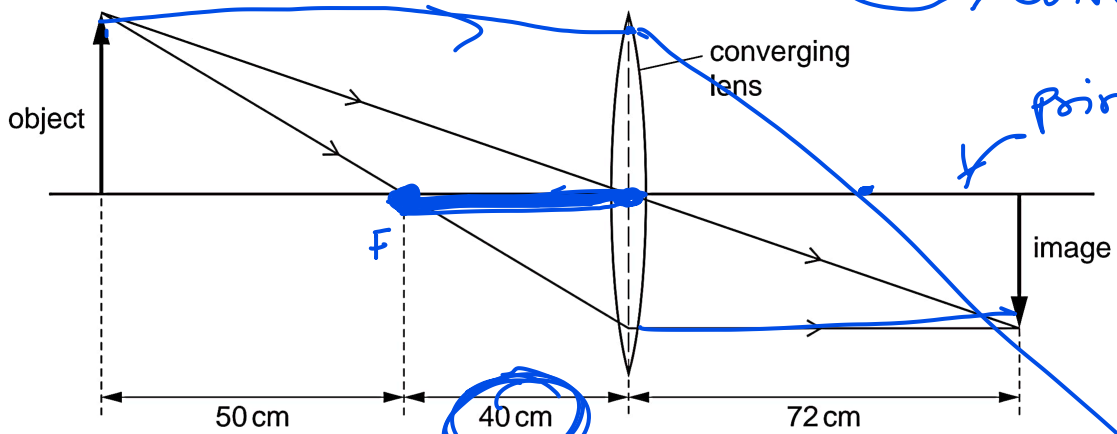

What is the focal length of the lens?

- A 40 cm B 50 cm C 72 cm D 90 cm

2 The diagram shows the dispersion of white light by a prism.

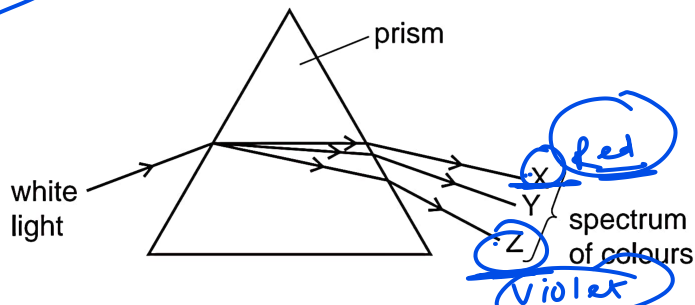

Which row could be correct for the colours seen at X, at Y and at Z?

	colour at X	colour at Y	colour at Z
A	red	violet	yellow
B	red	yellow	violet
C	violet	yellow	red
D	yellow	red	violet

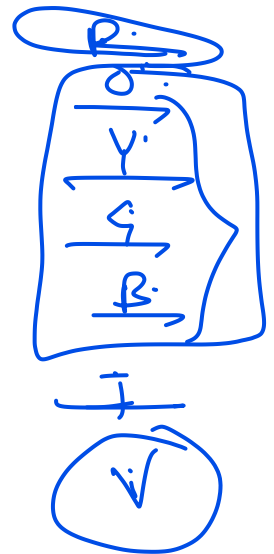

Handwritten notes on the left side of the page, including 'R', 'Y', 'G', 'B', 'I', 'V' and other scribbles.

3 The diagram shows a ray of light in air incident on a glass block. Some of the light is refracted, and some of the light is reflected. Two angles p and q are marked on the diagram.

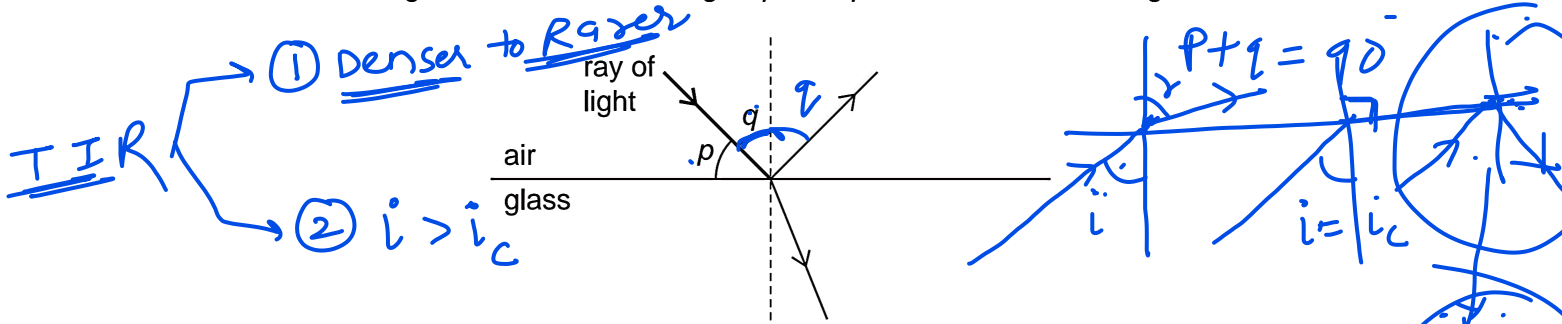

Which row gives the angle of incidence and shows whether the ray undergoes total internal reflection?

	angle of incidence	total internal reflection
A	p	no
B	p	yes
C	q	no
D	q	yes

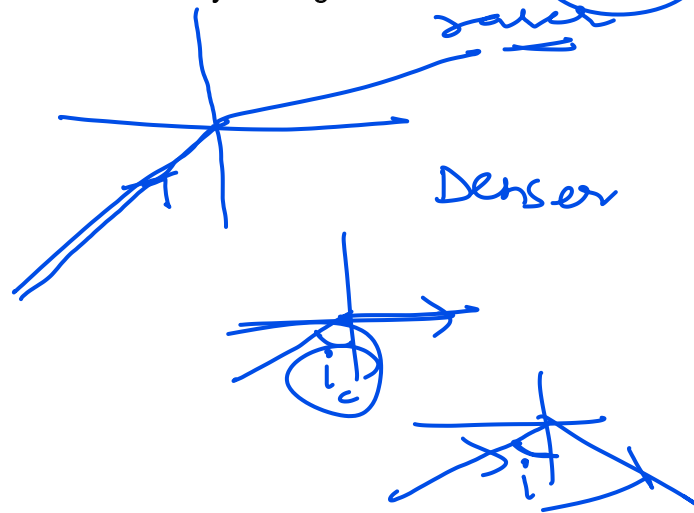

4 The diagram shows an object in front of a plane mirror.

At which labelled position is the image of the object formed?

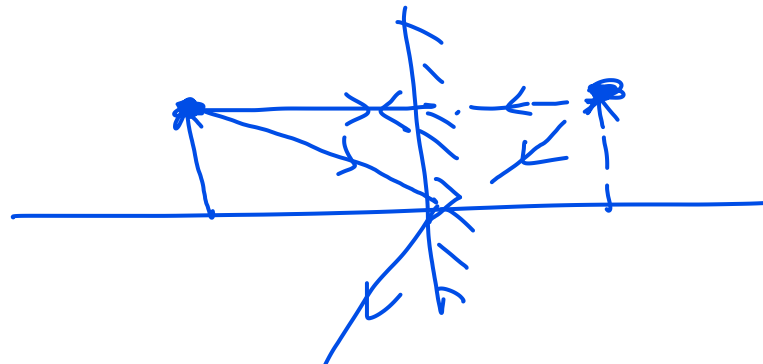
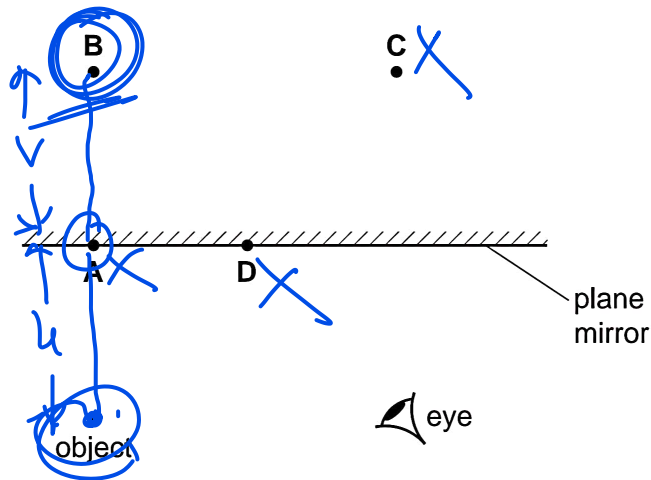

5 White light enters a glass prism. The light leaving the other side of the prism is separated into colours.

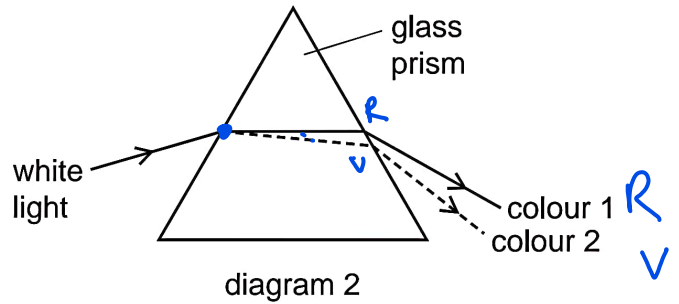
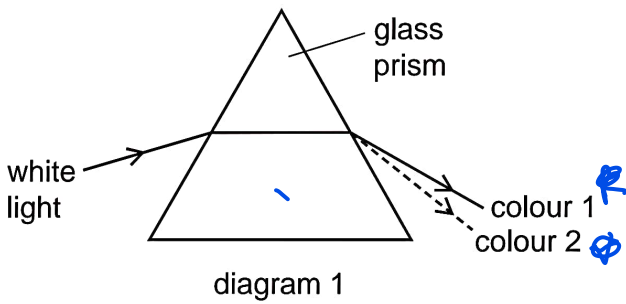

Which row correctly describes what happens?

	path taken by the light	colour 1	colour 2
A	diagram 1	red	violet
B	diagram 1	violet	red
C	diagram 2	red	violet
D	diagram 2	violet	red

6 Which diagram correctly shows a ray of light reflected by a plane mirror?

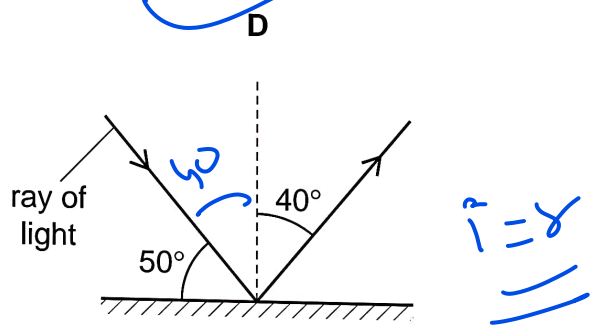
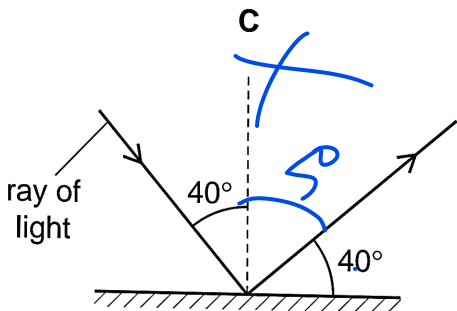
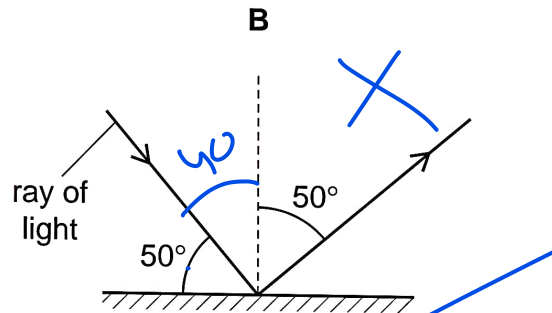
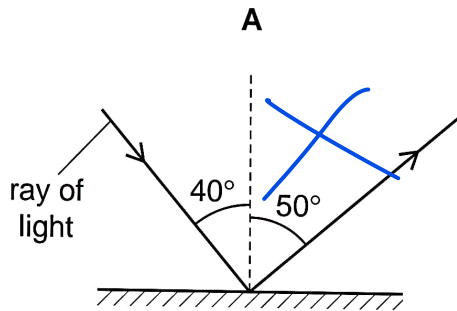

7 A ray of white light is incident on a glass prism.

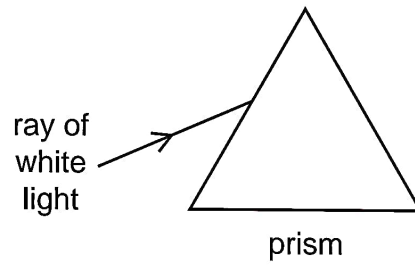

Which ray diagram shows the ray as it passes through the prism and emerges from the opposite side?

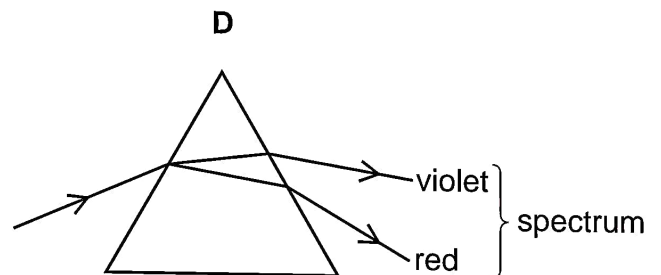
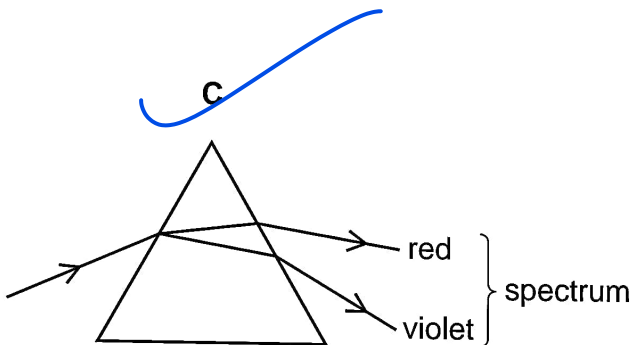
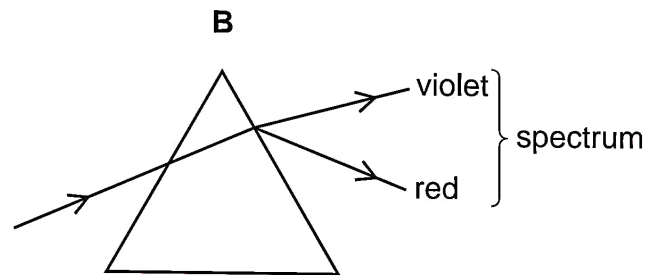
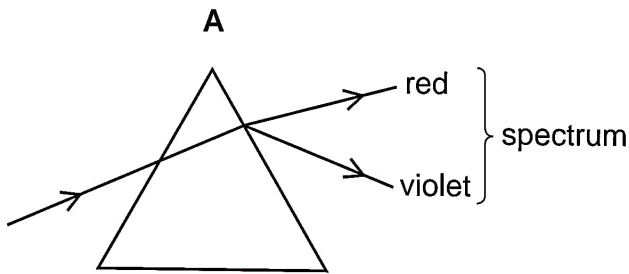

8 The diagram shows a ray of light incident on the edge of a piece of glass. The angle i is greater than the critical angle.

Which arrow shows the direction of the ray after it leaves the edge of the glass?

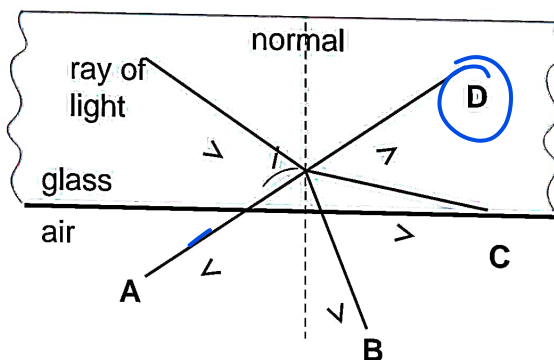

- 9 In the diagram, the distance OP is the focal length of the converging lens. One ray of light from O is shown.

Through which point will this ray pass, after refraction by the lens?

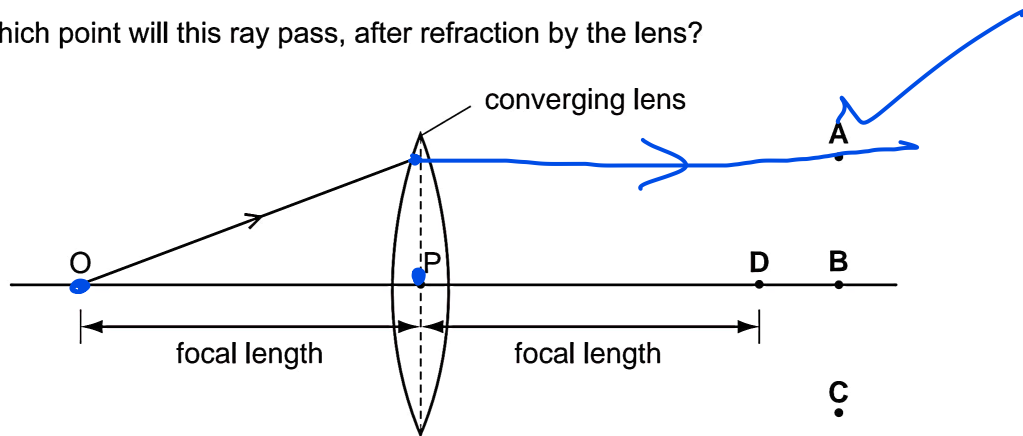

- 10 Light from the Sun passes through a narrow slit and a spectrum is produced on a screen.

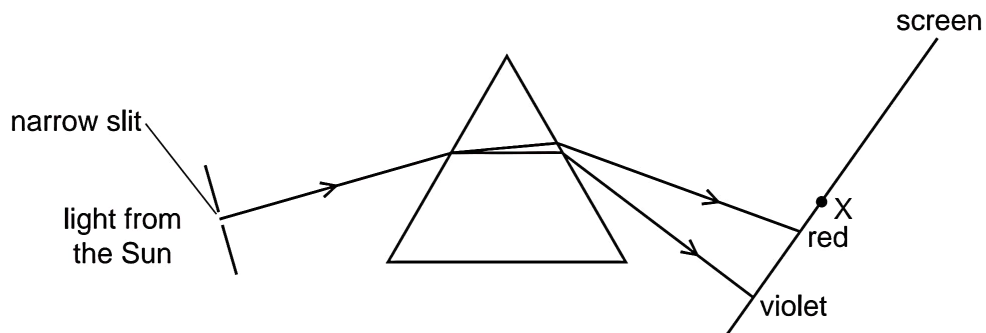

A thermometer placed at X shows a large temperature increase.

Which type of radiation causes this temperature increase?

- A infra-red
- B microwave
- C ultraviolet
- D visible light

11 The diagram shows the electromagnetic spectrum, in order of increasing wavelength.

Three types of radiation, P, Q and R, are missing from the spectrum diagram.

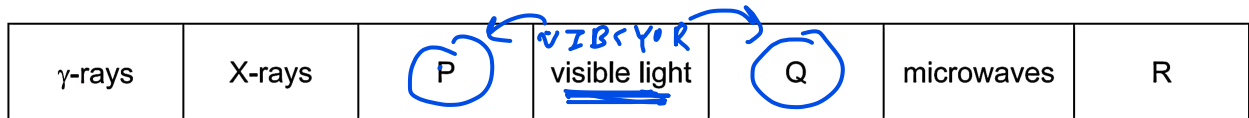

Which types of electromagnetic radiation are represented by P, by Q and by R?

	P	Q	R
A	infra-red	waves	ultraviolet
B	infra-red	ultraviolet	radio waves
C	ultraviolet	infra-red	radio waves
D	ultraviolet	waves	infra-red

12 Radiation from the Sun is dispersed by a prism. The prism does not absorb any of the radiation. Four identical thermometers are placed, one at each of the labelled positions.

In which position does the thermometer show the greatest rise in temperature?

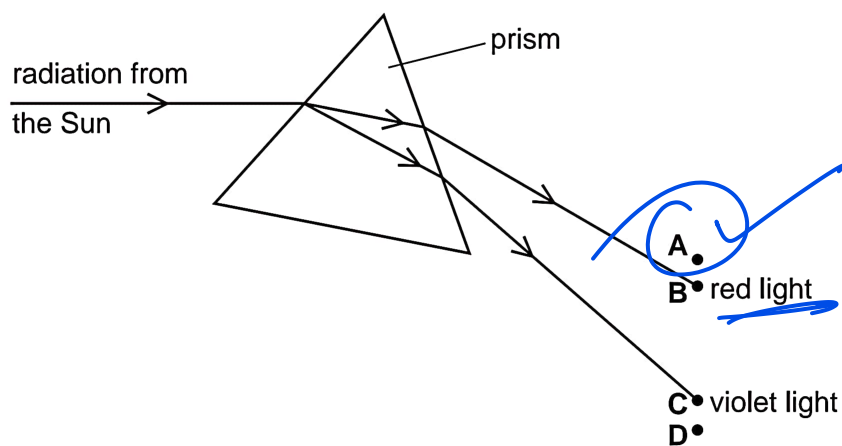

13 Which diagram shows how the light from a candle is reflected by a mirror, and shows the position of the image formed?

A

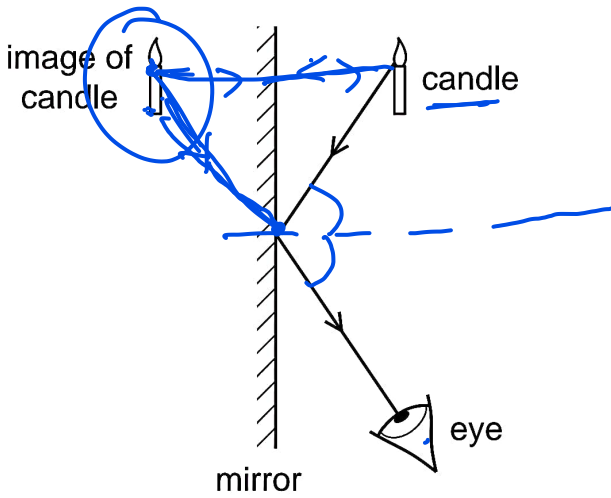

B

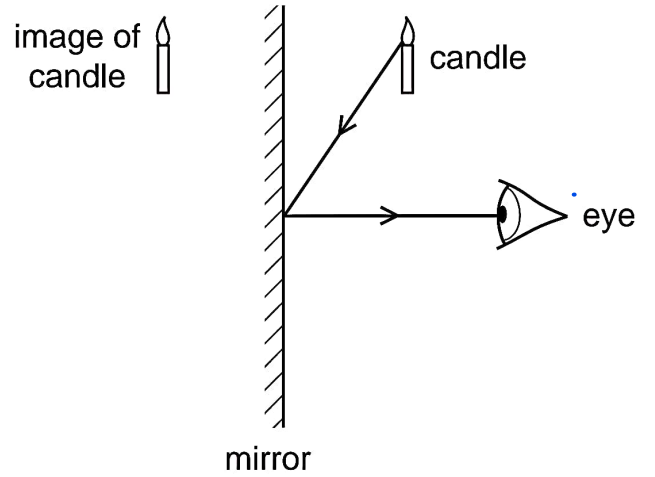

C

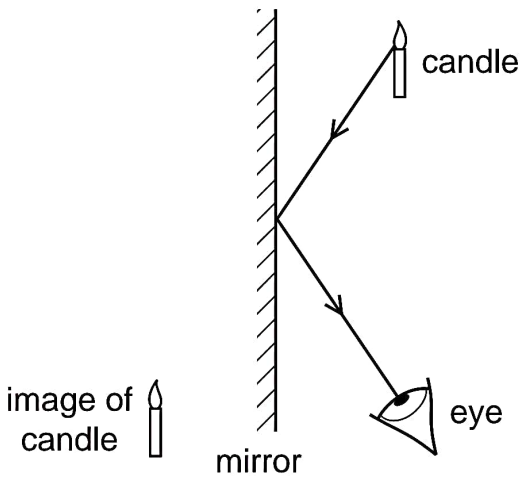

D

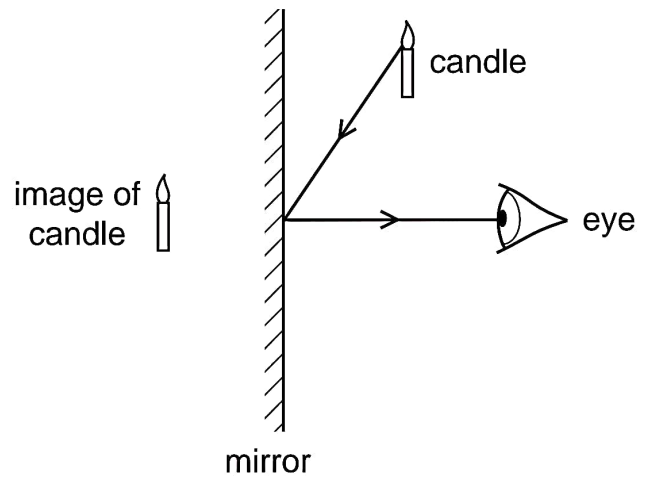

14 The diagram shows a ray of white light incident on a triangular glass prism.

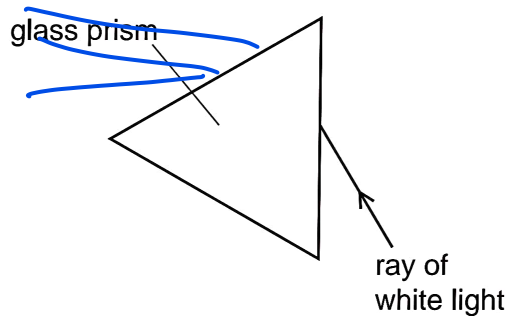

The ray enters the prism.

Which row correctly states if the light is refracted, and if the light is dispersed?

	refracted	dispersed
A	no	
B	no	<u>y</u>
C	yes	
D	yes	

15 A parallel beam of light falls on a converging lens.

Which diagram shows what happens to the beam of light?

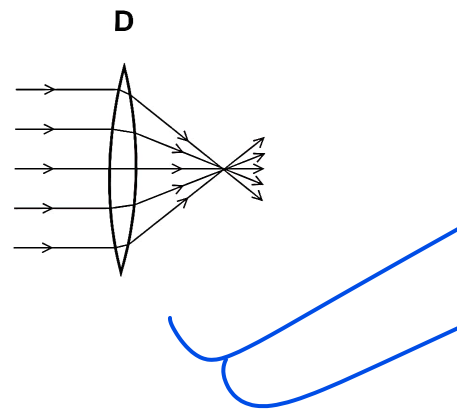
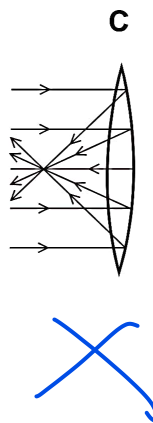
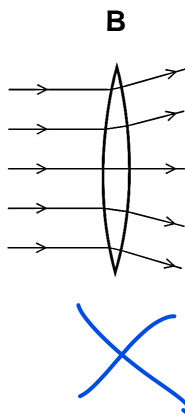
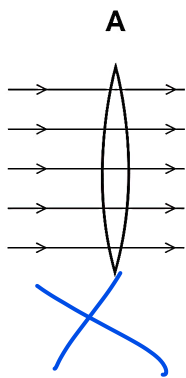

- 16 A student draws a diagram representing three rays of light from point P passing through a converging lens. Each point labelled F is a principal focus of the lens.

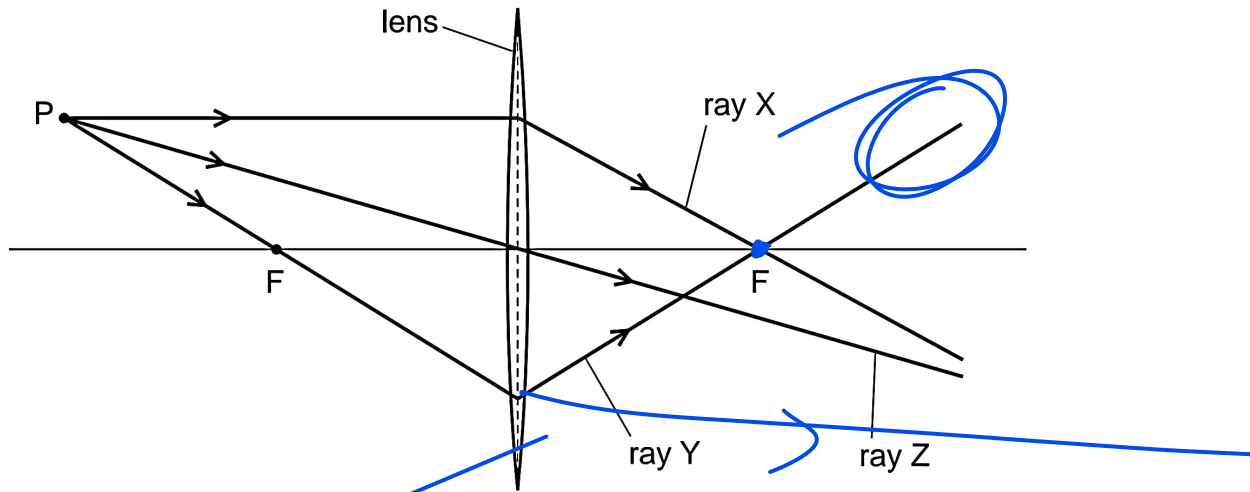

Which of the rays has the student drawn correctly?

- A ray X and ray Y
- B ray X and ray Z
- C ray Y only
- D ray Z only

- 17 The diagram shows a ray of light inside a glass rod. The critical angle for the light in the glass is 42° .

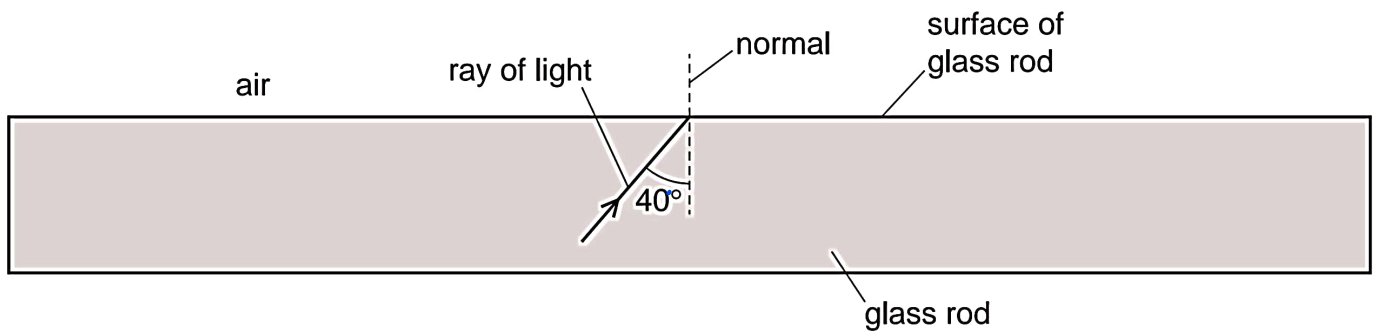

Which row shows what happens to the light when it reaches the surface of the glass rod?

	any light reflected?	any light refracted?
A	no	no
B	no	yes
C	yes	no
D	yes	yes

18 A plane mirror is fitted to a wall.

Which statement about the image formed by the mirror is correct?

- A The image is real.
- B The image is left to right (laterally inverted).**
- C The image is smaller than the object.
- D The image is upside down.

19 The diagram shows a ray of light travelling in a substance P. The ray reaches a boundary with a substance Q. Total internal reflection occurs at the boundary.

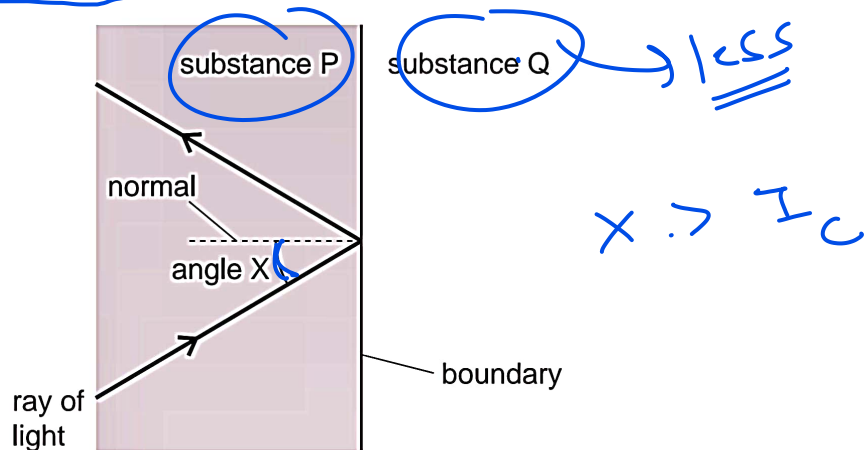

Which row contains correct statements about angle X and about the optical density of substance Q?

	angle X	substance Q
A	smaller than the critical angle	less dense than substance P
B	smaller than the critical angle	more dense than substance P
C	greater than the critical angle	less dense than substance P
D	greater than the critical angle	more dense than substance P

20 Which labelled distance is the focal length of the lens?

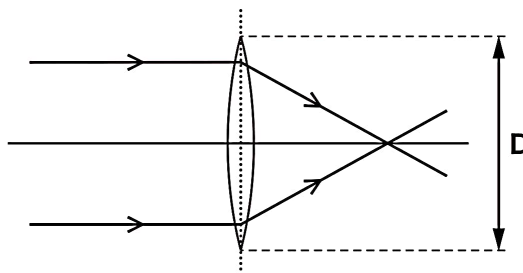
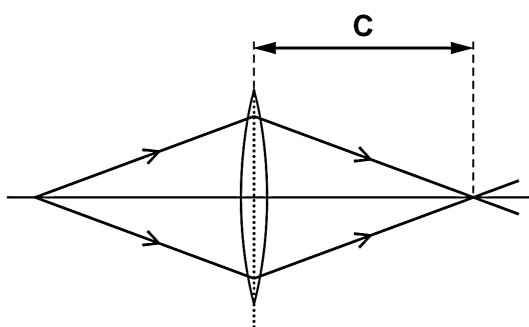
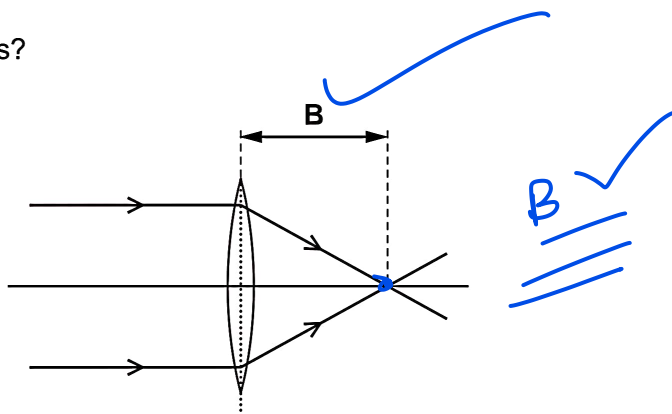
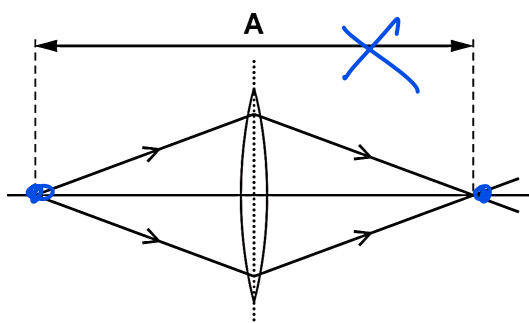

10

21 A ray of light is reflected by two parallel plane mirrors X and Y.

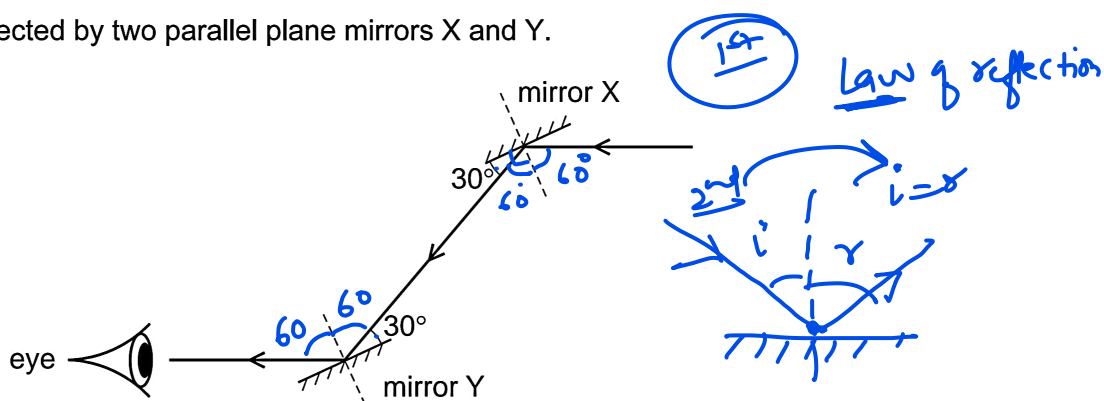

Which statement is correct?

- A The angle of incidence at mirror X is 30° .
- B The angle of incidence at mirror Y is 60° .
- C The angle of reflection at mirror X is 120° .
- D The angle of reflection at mirror Y is 0° .

22 Scout P signals to scout Q on the other side of a valley by using a mirror to reflect the Sun's rays.

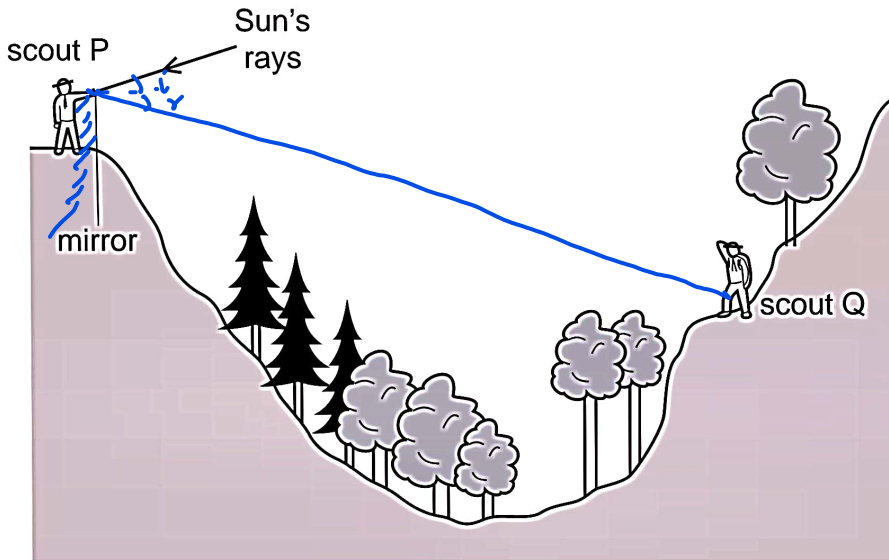

Which mirror position would allow the Sun's rays to be reflected to scout Q?

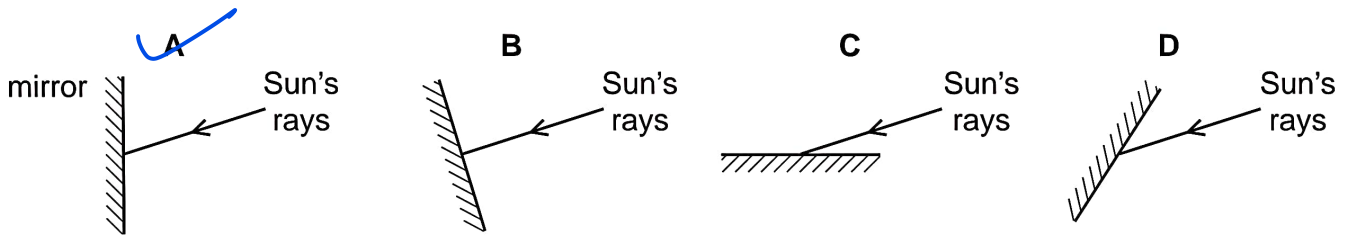

23 Which statement about a converging lens is **not** correct?

- A A ray parallel to the principal axis of the lens is refracted through the principal focus. ✓
- ~~B All rays of light refracted by the lens pass through the principal focus.~~
- C The distance between the centre of the lens and the principal focus is the focal length. ✓
- D The principal focus of the lens is a point on the principal axis. ✓

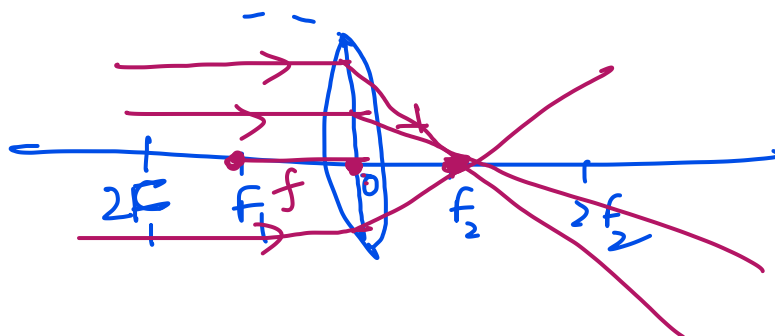

24 Rays of light enter and leave a box.

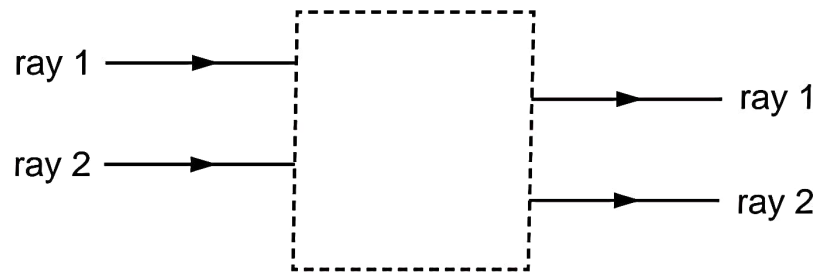

What could be inside the box to make the rays behave as shown?

- A a converging lens
- B a parallel-sided glass block
- C a plane mirror
- D a triangular prism

25 A boy wears a shirt with a letter F on the front. He stands in front of a plane mirror.

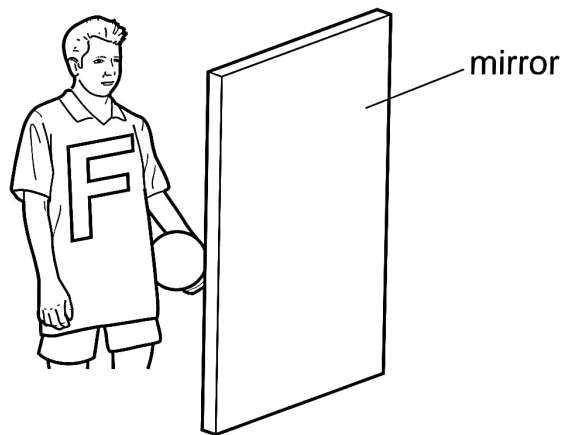

What does he see in the mirror?

- A B
-    

26 A small boat in a harbour is protected from waves on the sea by harbour walls.

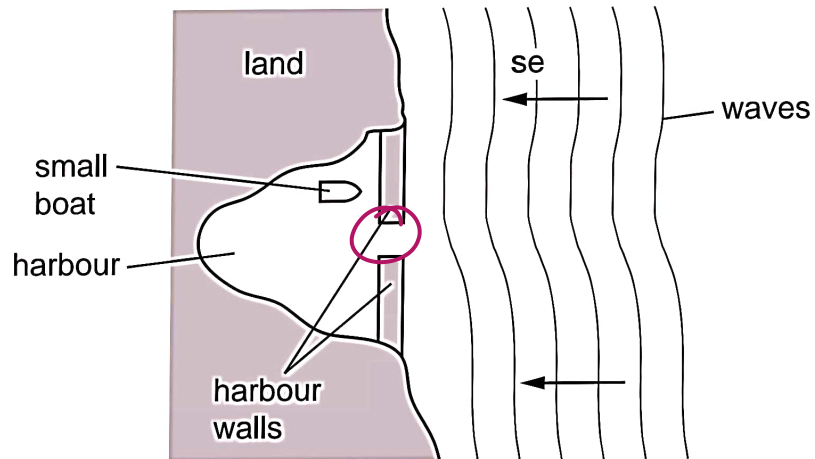

Some waves can curve round the harbour walls and reach the boat.

What is the name of this effect?

- A diffraction
- B dispersion
- C reflection
- D refraction

27 Which statement about a converging lens is **not** correct?

-
- A hand-drawn diagram of a converging lens is shown on the left. It features a horizontal principal axis with a central point labeled 'O'. Two focal points are marked as F_1 and F_2 on either side of the lens. The distance from the lens to each focal point is labeled as f . Two points further out on the axis are labeled $2F_1$ and $2F_2$. A ray of light is shown entering from the left, parallel to the principal axis, and refracting through the lens to pass through the focal point F_2 on the right.
- A A ray parallel to the principal axis of the lens is refracted through the principal focus. ✓
 - B All rays of light refracted by the lens pass through the principal focus. ✗
 - C The distance between the centre of the lens and the principal focus is the focal length. ✓
 - D The principal focus of the lens is a point on the principal axis. ✓

28 Light waves pass from air into glass and are refracted.

What always remains constant when this happens?

- A direction
- B frequency
- C speed
- D wavelength

29 An object is placed in front of a converging lens. The lens has a focal length f .

The lens produces a real, enlarged image of the object.

In which labelled position is the object placed?

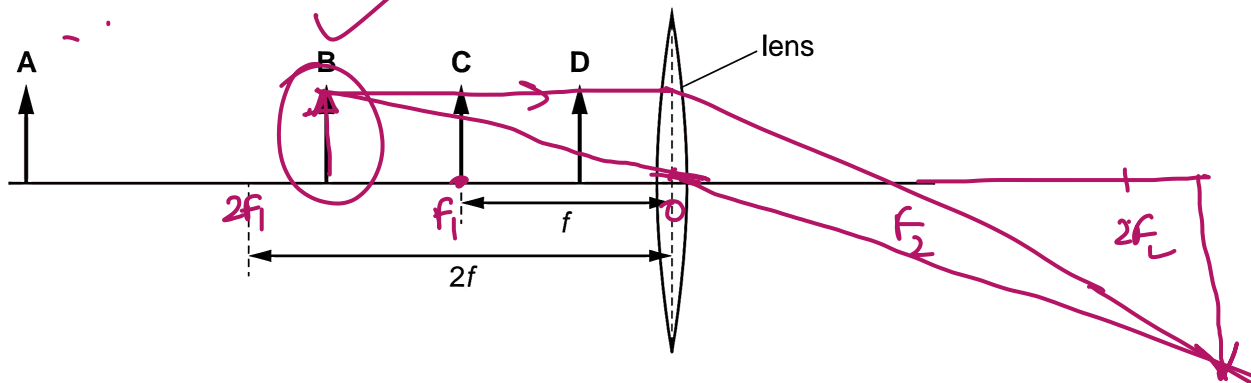

30 Which diagram shows how a ray of light could pass through a glass block in air?

A

B

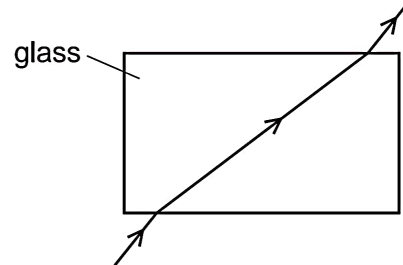
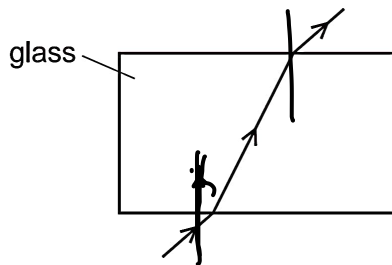

C

D

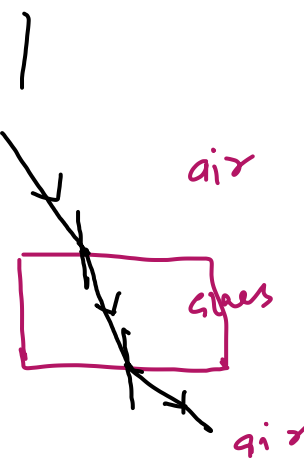
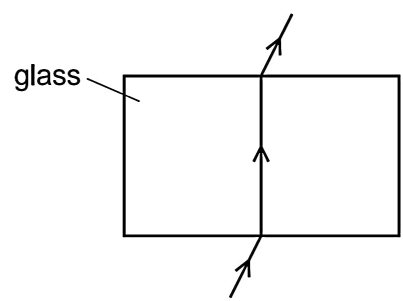
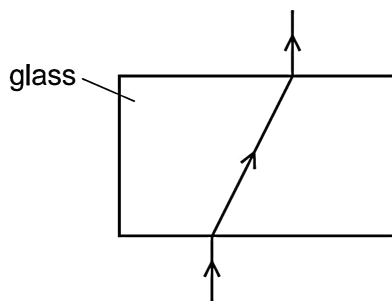

31 Which diagram correctly represents rays of light passing through a converging lens in a camera?

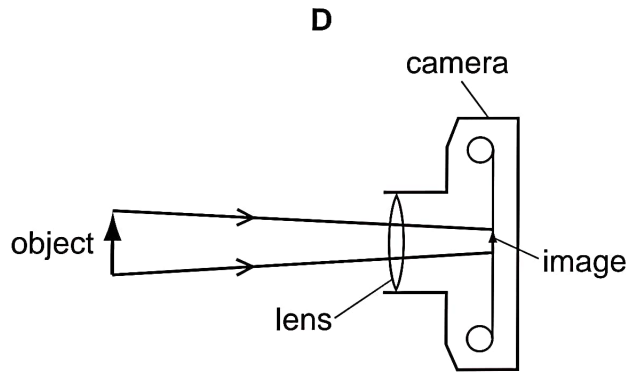
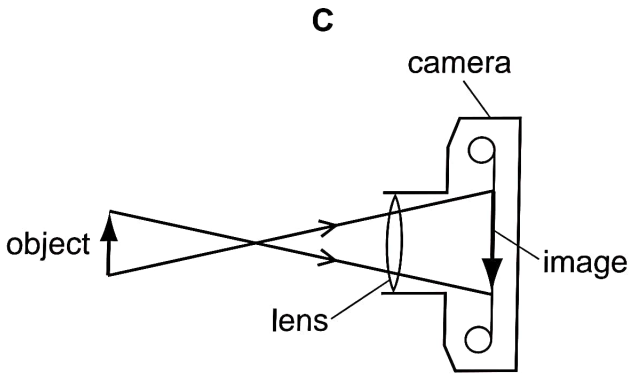
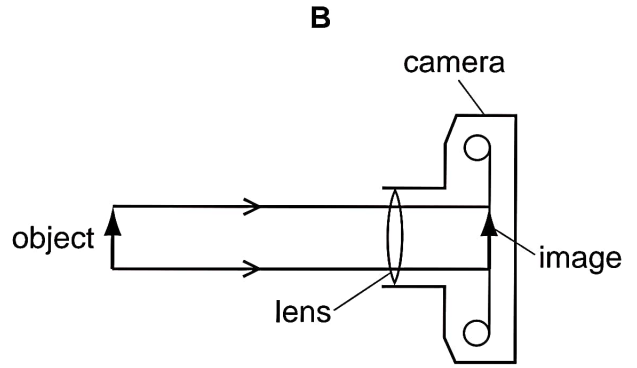
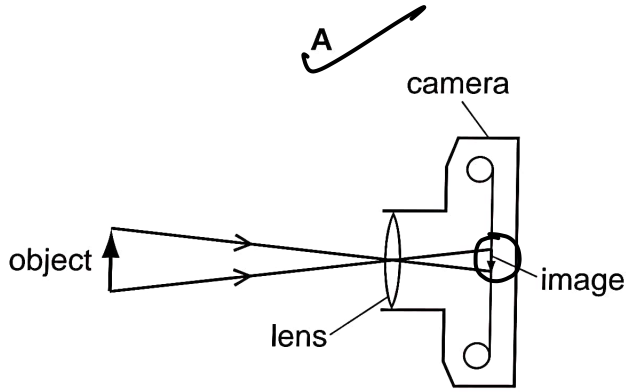

32 The diagram shows a ray of light passing through a semicircular glass block into air.

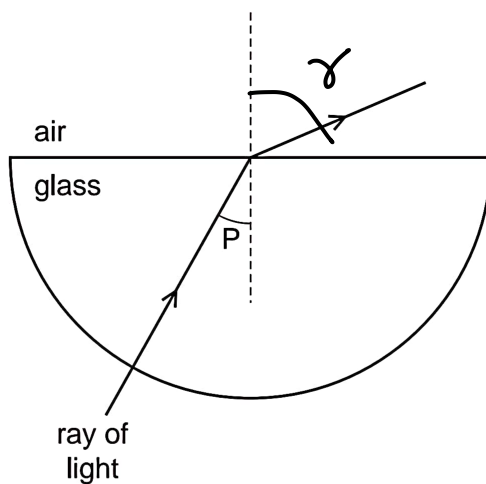

Which row gives the correct name for angle P and states how angle P compares with the critical angle?

	name of angle P	angle P compared with the critical angle
A	angle of incidence	larger than the critical angle
B	angle of incidence	smaller than the critical angle
C	angle of refraction	larger than the critical angle
D	angle of refraction	smaller than the critical angle

33 Which diagram shows how an image of an object is formed on a screen by a converging lens?

A

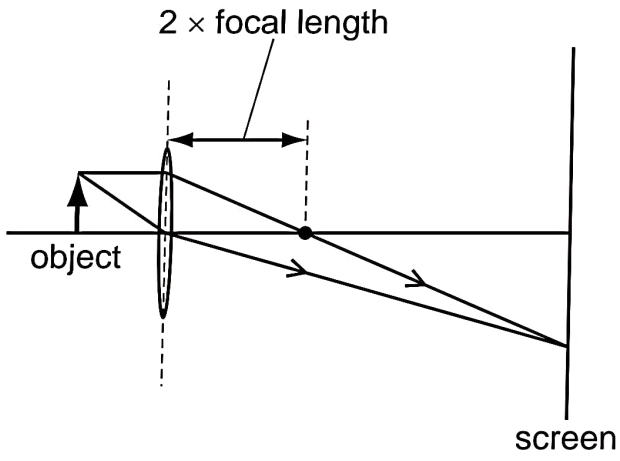

B

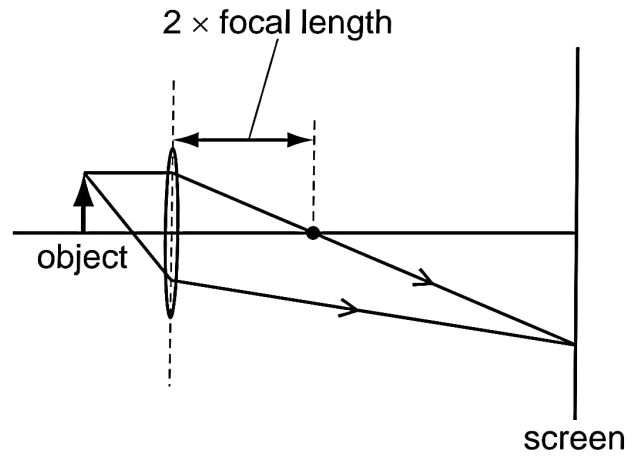

C

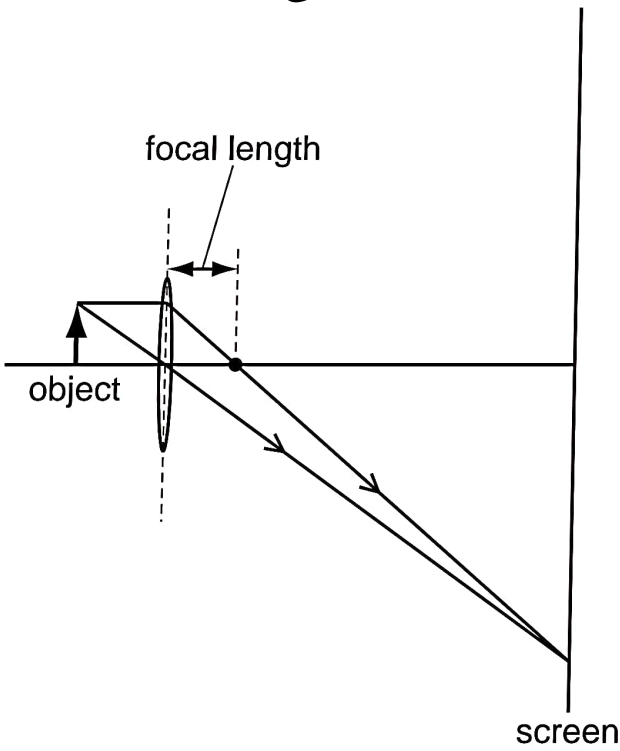

D

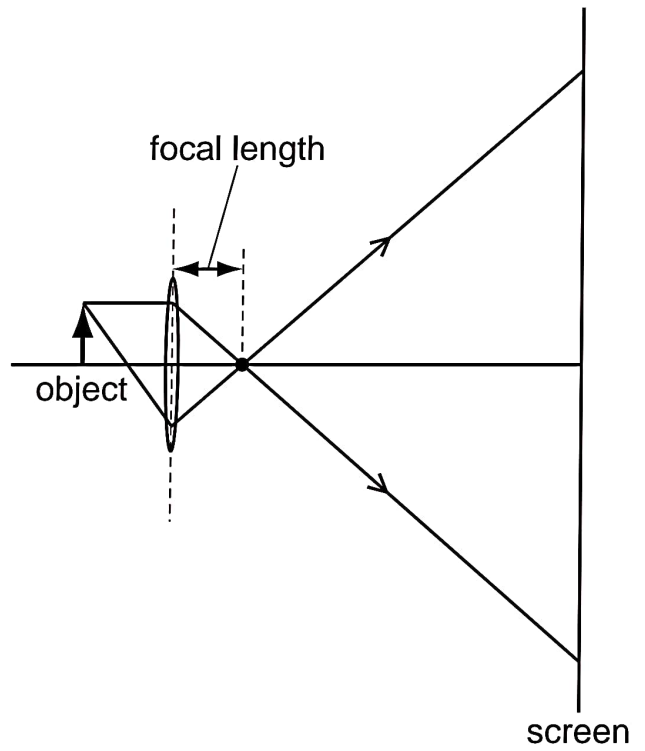

34 Water waves may be used to demonstrate refraction by making them pass into water of a different depth.

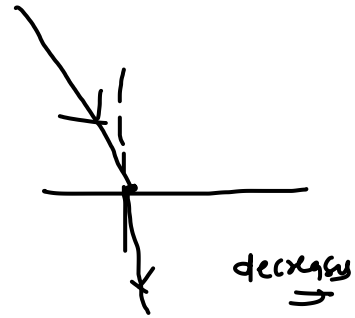
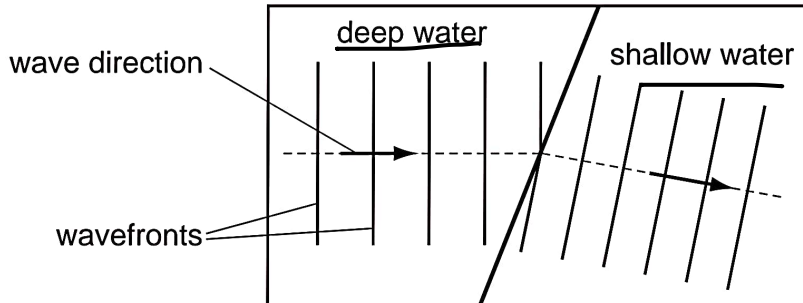

Why does the water wave change direction as it passes into the shallow water?

- A The frequency of the wave decreases.
- B The frequency of the wave increases.
- C The speed of the wave decreases.
- D The speed of the wave increases.

35 The diagram represents a converging lens forming an image of an object.

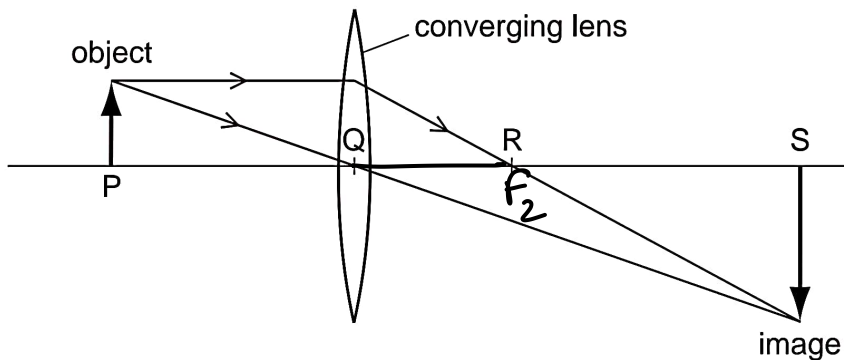

Which distance is the focal length of the lens?

- A PQ
- B PR
- C QR
- D QS

36 A teacher demonstrates the dispersion of white light using a triangular glass prism.

Which diagram shows how this dispersion happens?

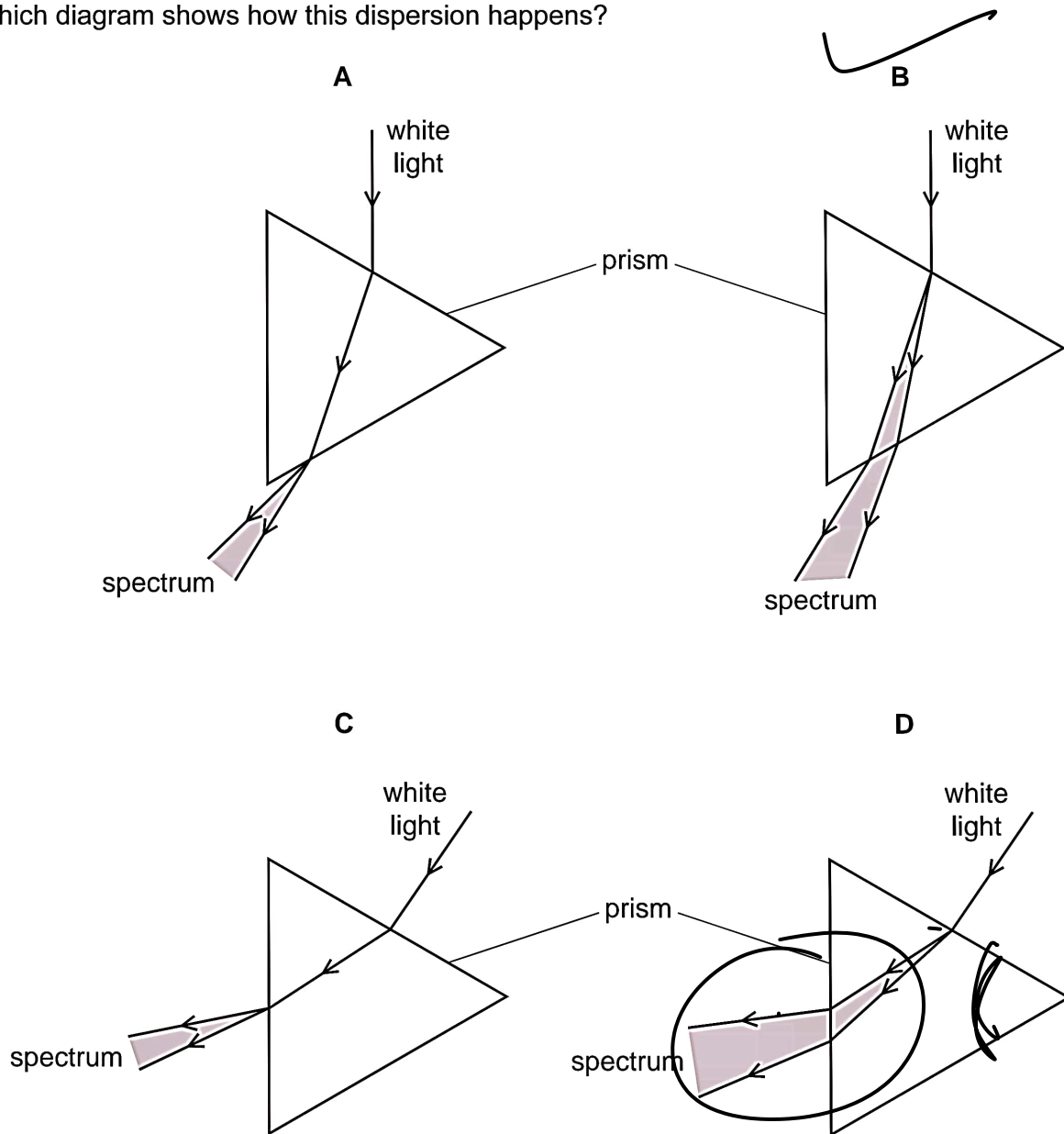

37 The image formed by a plane mirror is upright.

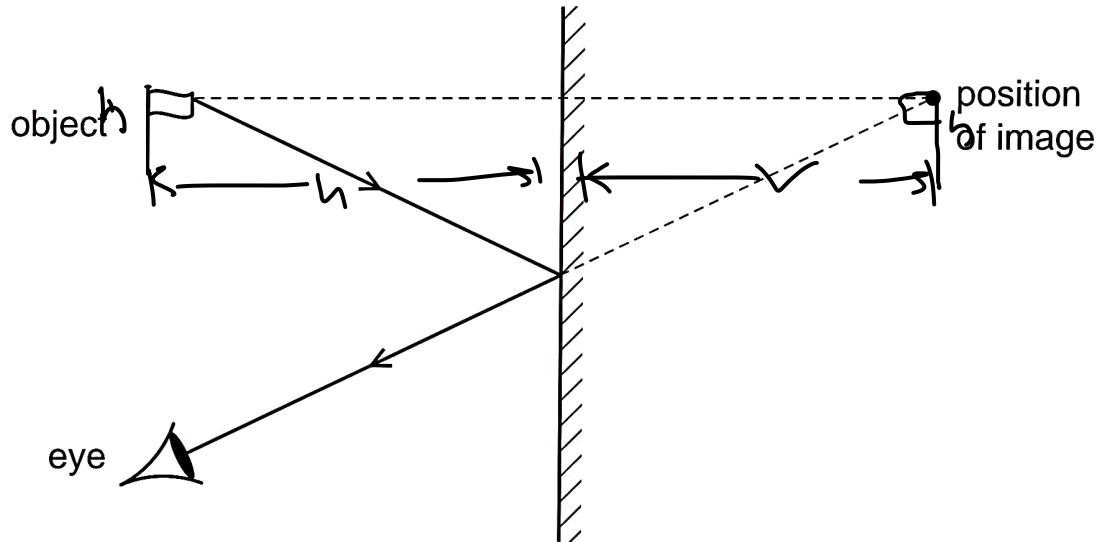

What are the other characteristics of the image?

	laterally inverted (left to right)	magnified (larger than the object)	virtual
A	no	yes	yes
B	yes	no	no
C	<u>yes</u>	<u>no</u>	<u>yes</u>
D	yes	yes	no

38 A student draws three rays of light from point P through a converging lens.

Each point labelled F is a principal focus of the lens.

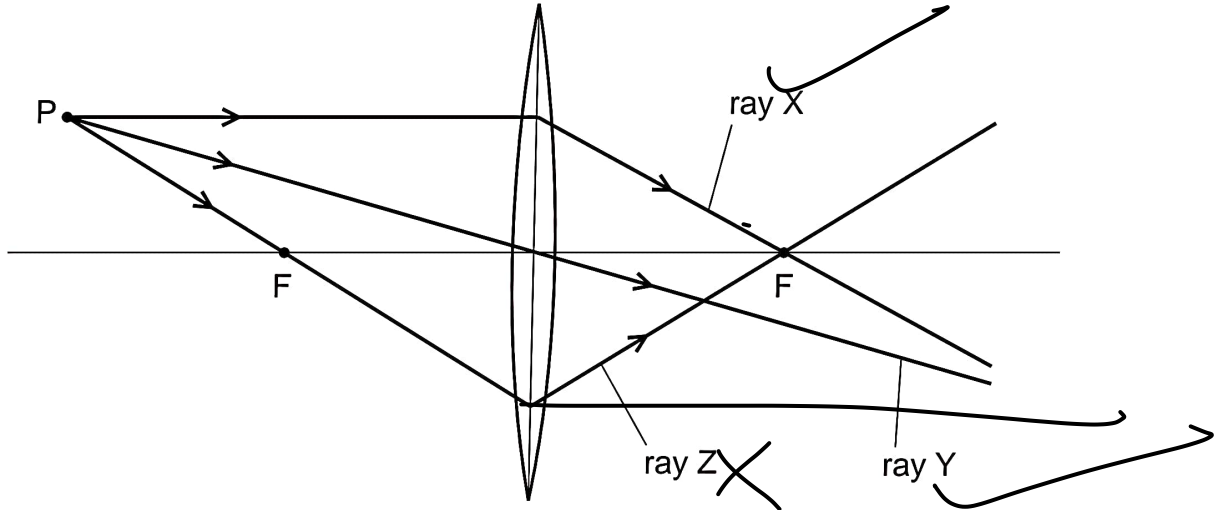

Which of the rays are drawn correctly?

A ray Y only

~~B ray Z only~~

C ray X and ray Y

D ray X and ray Z

39 The diagram shows radiation from a lamp passing through a prism.

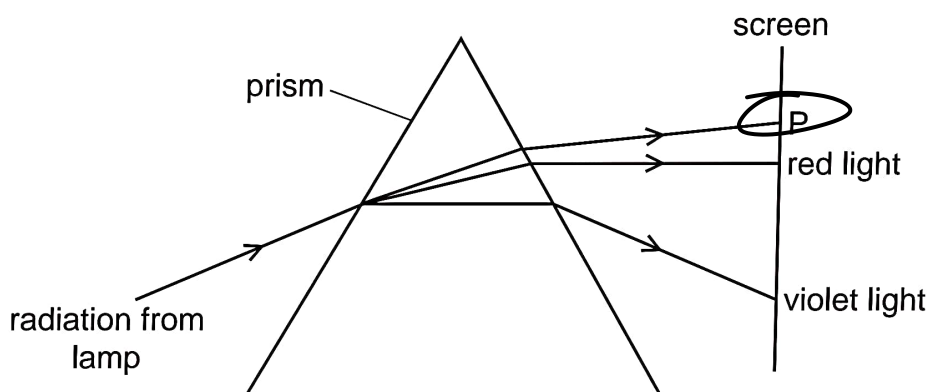

Which type of radiation is found at P?

~~A γ -rays~~

B infra-red

C ultraviolet

D X-rays

40 A plane mirror is used to form an image of an object.

At which labelled point is the image formed?

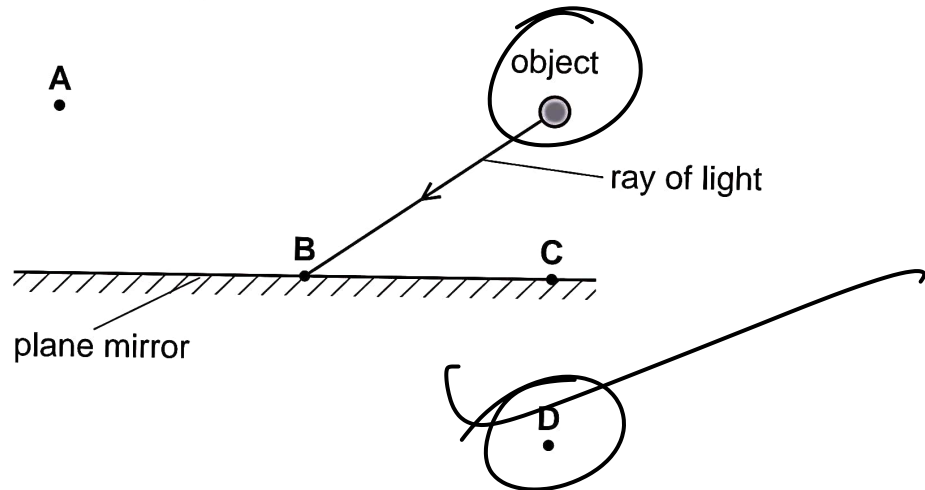

41 A converging lens in a projector is used to make an **enlarged** image of a small piece of film on a screen.

At which labelled point could the piece of film be placed so that the lens produces this image?

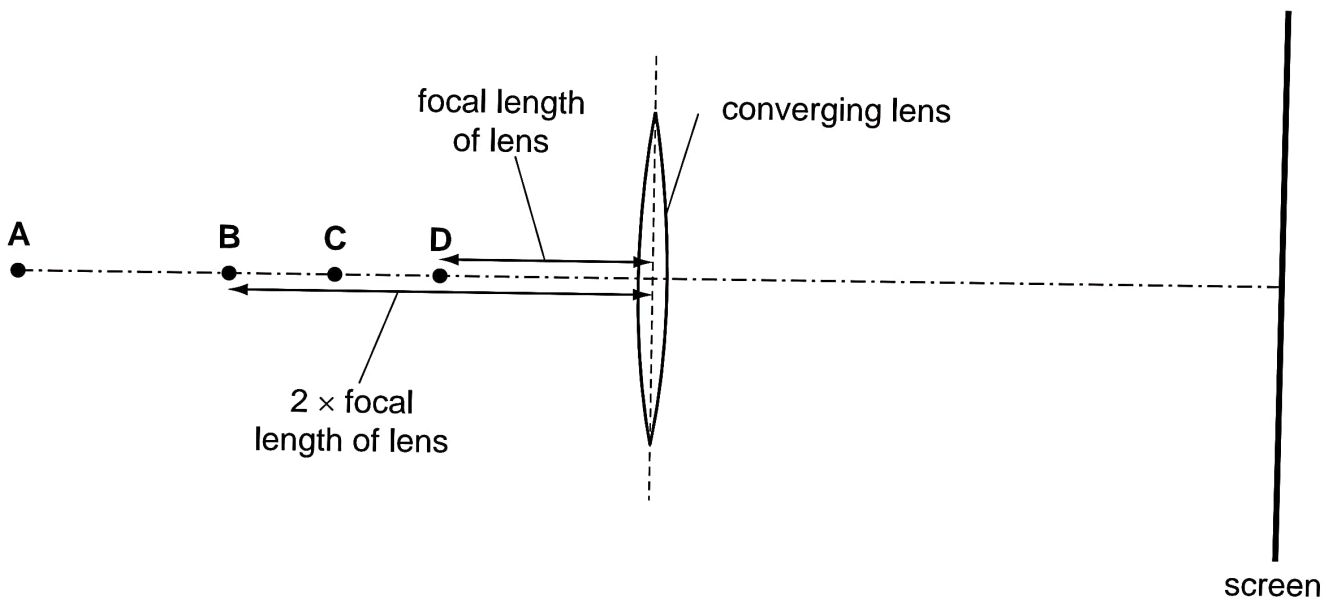

42 The diagram shows the dispersion of white light by a glass prism.

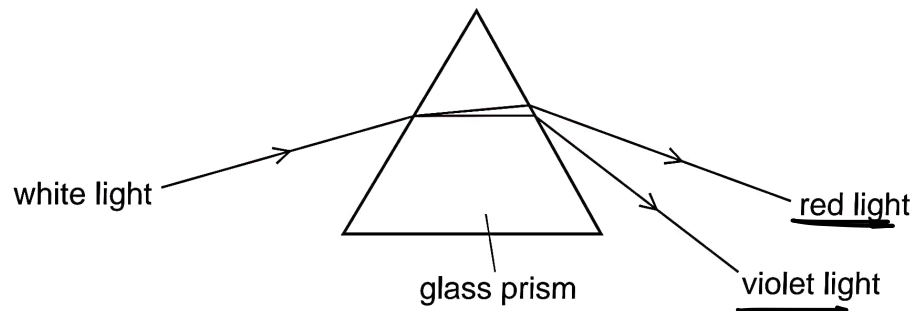

Why does dispersion occur when white light enters the glass?

A The frequency of red light decreases more than that of violet light.

B The frequency of violet light decreases more than that of red light.

C The speed of red light decreases more than that of violet light.

D The speed of violet light decreases more than that of red light.

43 A thin converging lens is used to produce, on a screen, a focused image of a candle.

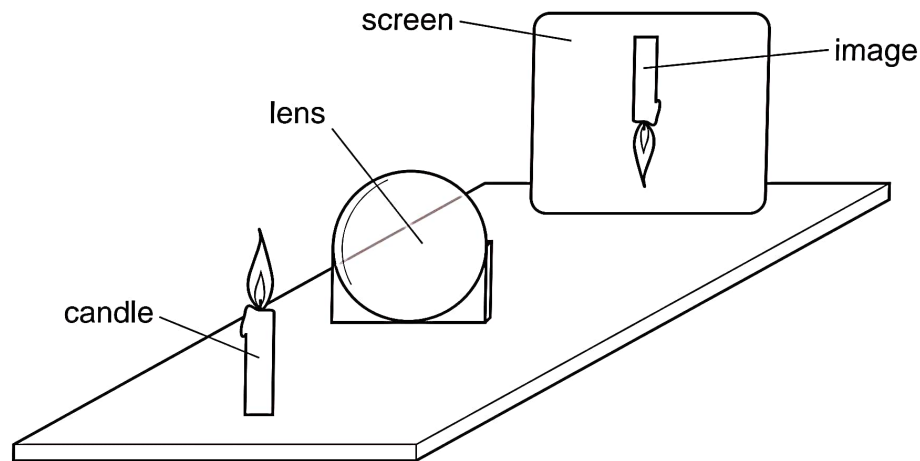

Various focused images are produced on the screen by moving the lens and the screen backwards and forwards.

Which statement is **always** correct?

A The image is at the principal focus (focal point) of the lens.

B The image is bigger than the object.

C The image is closer to the lens than the object is.

D The image is inverted.

- 44 The diagram shows a ray of light travelling from X. Angle P is less than the critical angle.
In which direction does the ray continue?

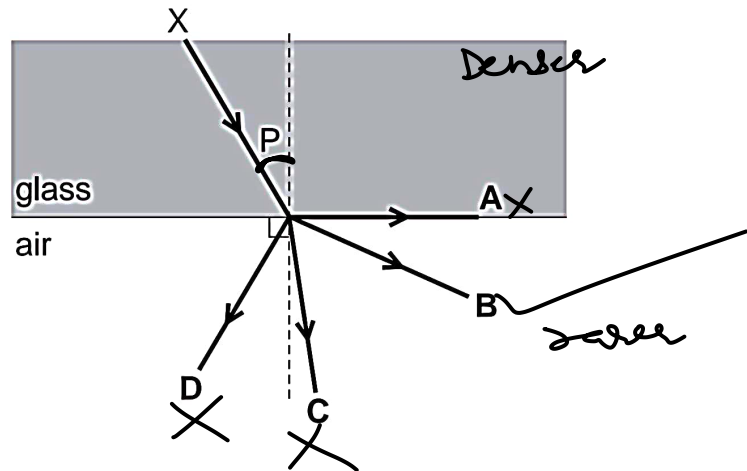

- 45 The diagram shows the image of a clock in a plane mirror.

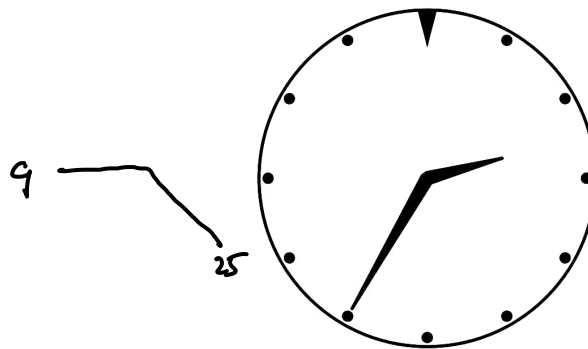

What time is shown?

- A 02:25 B 02:35 C 09:25 D 09:35

46 The diagram shows light travelling from air into glass.

Four angles v , w , x and y are shown.

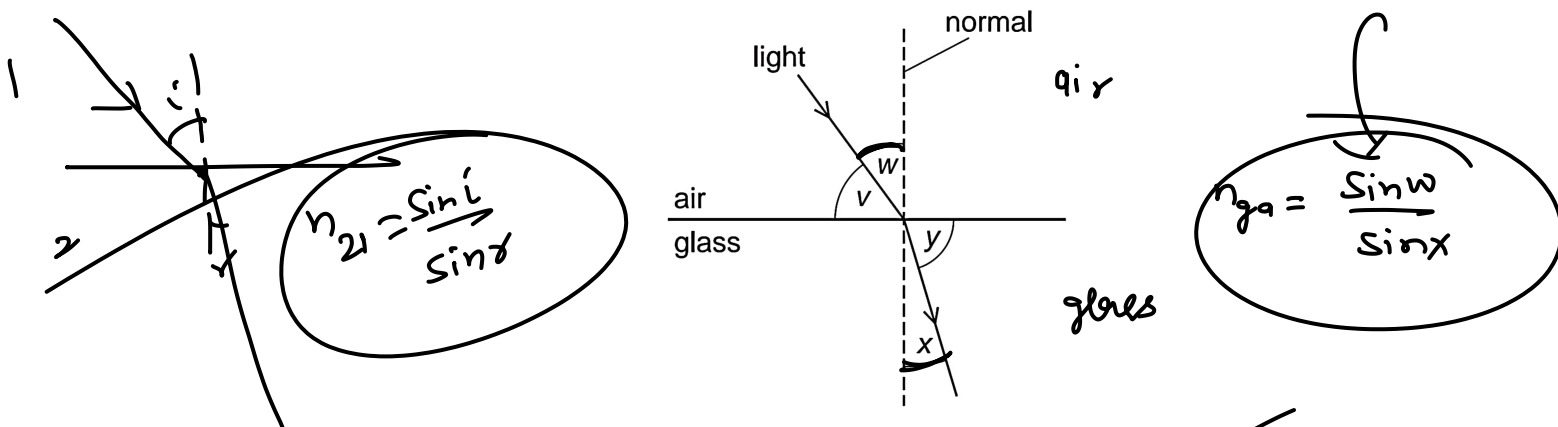

Which formula is used to calculate the refractive index n of the glass?

- A $n = \frac{\sin v}{\sin y}$
 B $n = \frac{\sin v}{\sin x}$
 C $n = \frac{\sin w}{\sin y}$
 D $n = \frac{\sin w}{\sin x}$

47 The diagram shows a converging lens forming an image of an object.

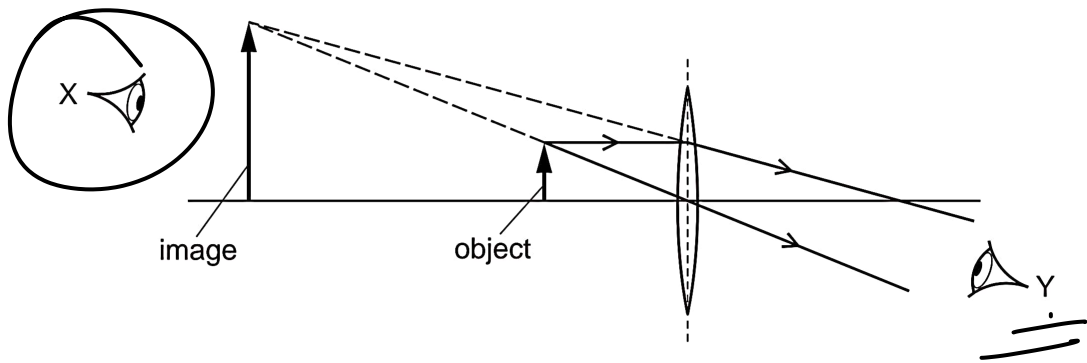

Which statement about the image is correct?

- A It is real and can be seen by an eye at X.
 B It is real and can be seen by an eye at Y.
 C It is virtual and can be seen by an eye at X.
 D It is virtual and can be seen by an eye at Y.

48 The diagram shows light passing from air into glass.

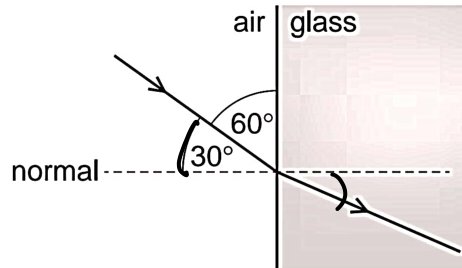

NOT TO SCALE

The glass has a refractive index of 1.5.

What is the angle of refraction in the glass?

- A 19° B 22° C 35° D 49°

$$1.5 = \frac{\sin 30}{\sin r}$$

$$1.5 = \frac{1}{2 \sin r}$$

$$3 = \frac{1}{\sin r}$$

$$\sin r = \frac{1}{3}$$

$$\underline{\underline{r = \sin^{-1}\left(\frac{1}{3}\right)}}$$

49 A sound wave has a certain amplitude and a certain frequency.

A second sound wave is quieter and lower in pitch than the first sound wave.

The second wave has

- A a larger amplitude and a greater frequency.
 B a larger amplitude and a smaller frequency.
 C a smaller amplitude and a greater frequency.
D a smaller amplitude and a smaller frequency.

50 The diagram shows an object in front of a plane mirror. The mirror forms an image of the object.

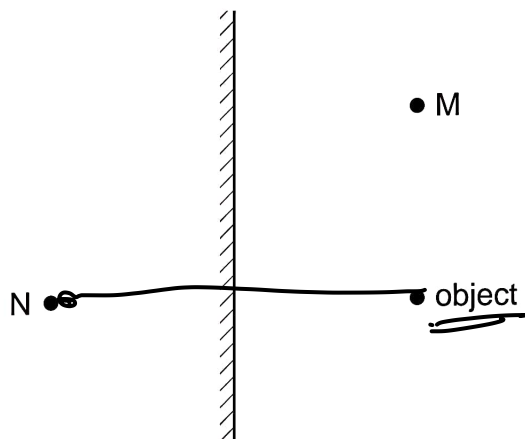

At which labelled point is the image formed, and which type of image is formed?

	where the image is formed	type of image
A	at M	real
B	at M	virtual
C	at N	real
D	at N	virtual

51 Light enters a glass block at an angle of incidence of 46° .

The light refracts at an angle of refraction of 26° .

What is the refractive index of the glass?

A 0.57

B 0.61

C 1.64

D 1.77

$$n = \frac{\sin 46}{\sin 26}$$

52 Which diagram correctly shows a ray of light reflected by a plane mirror?

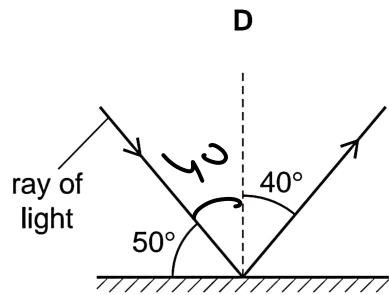
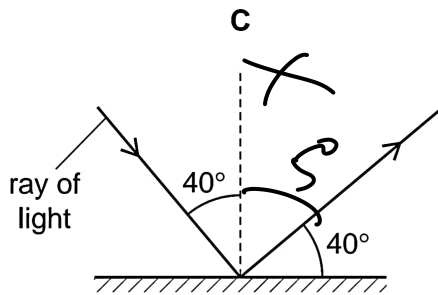
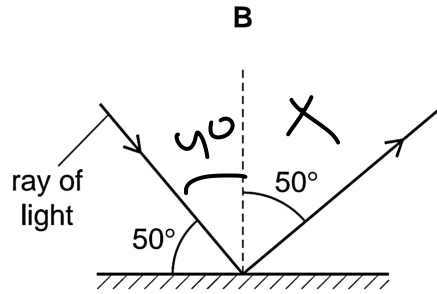
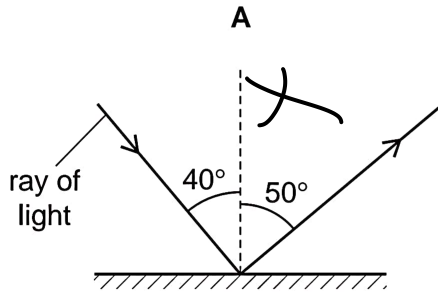

53 Which diagram shows how a converging lens is used as a magnifying glass?

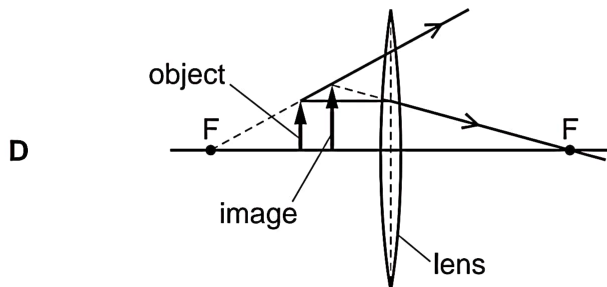
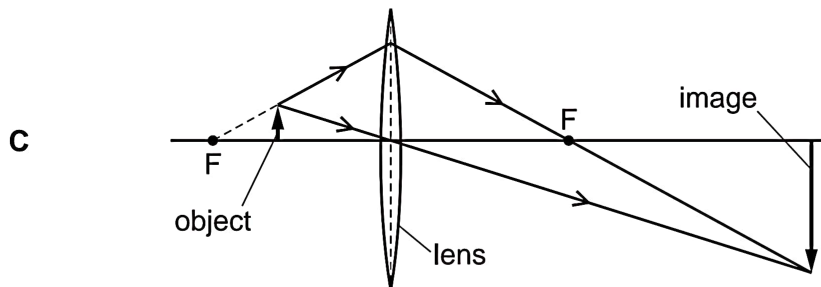
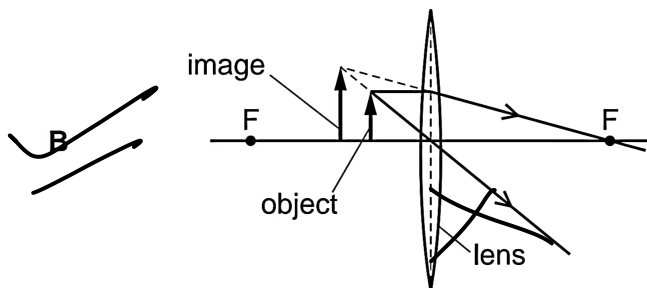
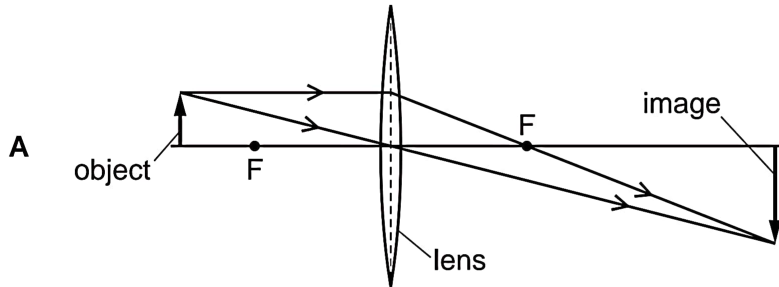

54 The diagram shows a ray of monochromatic light passing through a semi-circular glass block.

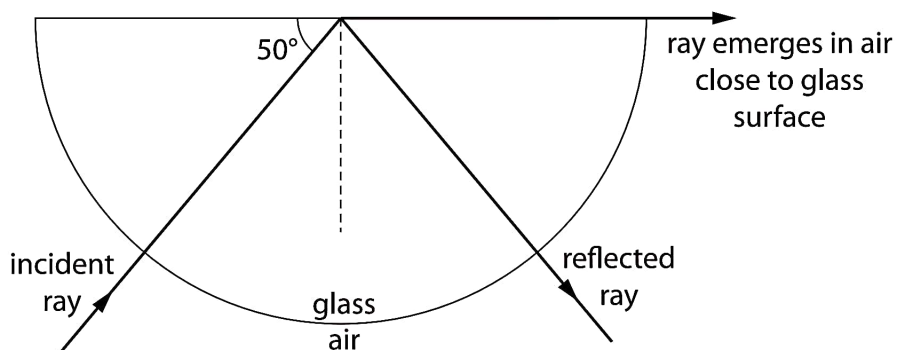

What is the refractive index of the glass?

- A 0.64 B 0.77 C 1.31 D 1.56

55 An object O is placed close to a thin converging lens.

The diagram represents three rays from the top of O passing through the lens.

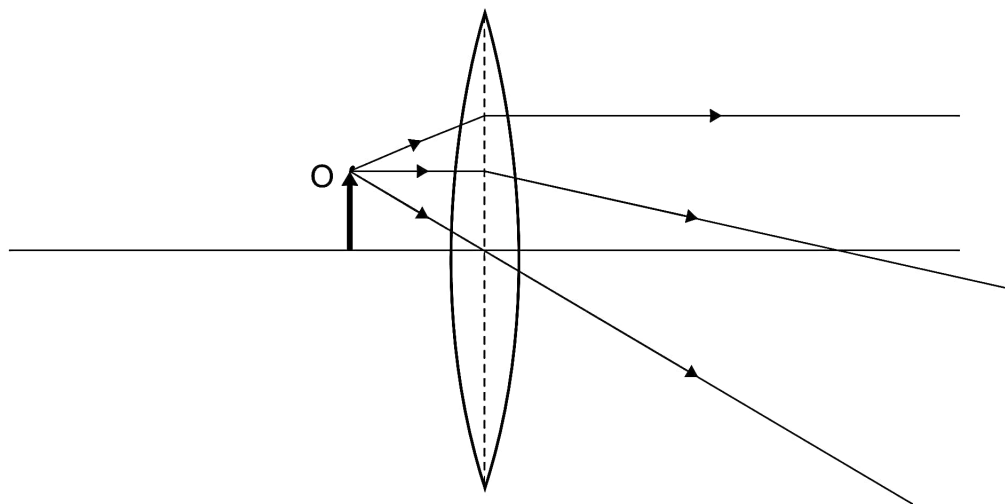

Which type of image is produced by the lens when the object O is in this position?

- A real and diminished
 B real and enlarged
 C virtual and diminished
D virtual and enlarged